



education

Department of
Education
FREE STATE PROVINCE

PHYSICAL SCIENCES PAPER 1 (PHYSICS)

GRADE 12

TERMS & DEFINITIONS, QUESTIONS & ANSWERS PER TOPIC

2019

TABLE OF CONTENTS

HOW TO USE THIS DOCUMENT	2
TERMS AND DEFINITIONS	3
QUESTIONS	7
NEWTON'S LAWS	7
VERTICAL PROJECTILE MOTION	13
MOMENTUM AND IMPULSE	18
WORK, ENERGY AND POWER.....	23
DOPPLER EFFECT.....	29
ELECTROSTATICS.....	34
ELECTRIC CIRCUITS	42
ELECTRICAL MACHINES	50
OPTICAL PHENOMENA AND PROPERTIES OF MATERIALS	54
ANSWERS TO QUESTIONS	62
NEWTON'S LAWS	62
VERTICAL PROJECTILE MOTION	69
MOMENTUM AND IMPULSE	79
WORK, ENERGY AND POWER.....	83
DOPPLER EFFECT.....	91
ELECTROSTATICS.....	95
ELECTRIC CIRCUITS	104
ELECTRICAL MACHINES	112
OPTICAL PHENOMENA AND PROPERTIES OF MATERIALS	117
BIBLIOGRAPHY	124

HOW TO USE THIS DOCUMENT

Dear Grade 12 learner

1. This document was compiled as an extra resource to help you to perform well in Physical Sciences.
2. Firstly you must make sure that you study the terms and definitions provided for each topic. Theory always forms part of any test or examination and you should ensure that you obtain full marks for ALL theory questions. Always be prepared to write a test on terms and definitions as soon as a topic is completed in class. Revise terms and definitions of topics already completed frequently so that you know them by the time you are sitting for a test or an examination.
3. Answer all the questions on a certain topic in your homework book as soon as the topic is completed. DO NOT look at the answers before attempting the questions. First try it yourself. Compare your answers with the answers at the back of the document. Mark your work with a pencil and do corrections for your incorrect answers. If you do not know how to answer a question, the answers are there to guide you. Acquaint yourself with the way in which a particular type of question should be answered. Answers supplied are from memoranda used to mark the questions in previous years.
4. Your teacher can, for example, give you two of the questions in this document as homework. The following day he/she will just check whether you answered them and whether you marked your answers. The teacher will only discuss those questions in which you do not understand the answers supplied in the document. Therefore a lot of time will be saved.
5. You are probably thinking about the point behind the answers at the back of the document. It is intended to help you to prepare for your tests and examinations. If you choose to copy answers into your homework book without trying them out yourself, you will be the losing party in the end! Not your teacher or anybody else!
6. Your teacher can also decide to give you a test on one of the questions given for homework. If you just copied the answers without any understanding, surely he/she will catch you! None of us want to be branded as dishonest, do we?
7. Work through all the questions and answers of a particular topic before you sit for an examination, even if you answered the questions before.
8. Any additional resource is only of help when used correctly. Ensure that you make use of all help provided in the correct way to enable you to be successful. All the best for 2019 and may you perform very well in Physical Sciences.

Impulse-momentum theorem	In symbols: $F_{\text{net}}\Delta t = m\Delta v = m(v_f - v_i)$ Unit: N·s or kg·m·s ⁻¹
Elastic collision	A collision in which both total momentum and total kinetic energy are conserved.
Inelastic collision	A collision during which kinetic energy is not conserved.

MECHANICS: VERTICAL PROJECTILE MOTION	
1-D motion	One-dimensional motion./Linear motion./Motion in one line.
Acceleration	The rate of change of velocity. Symbol: a Unit: meters per second squared (m·s ⁻²)
Gravitational acceleration (g)	The acceleration of a body due to the force of attraction of the earth.
Displacement	Change in position. Symbol: Δx (horizontal displacement) or Δy (vertical displacement) Unit: meters (m)
Free fall	The type of motion in which the only significant vertical force acting on the body is the body's weight.
Gravitational force	A force of attraction of one body on another due to their masses.
Position	Where an object is relative to a reference point. Symbol: x (horizontal position) or y (vertical position) Unit: meters (m)
Projectile	An object in free fall.
Velocity	The rate of change of position. Symbol: v Unit: meters per second (m·s ⁻¹)

MECHANICS: WORK, ENERGY AND POWER	
Work	Work done on an object by a constant force is the product of the magnitude of the force, the magnitude of the displacement and the angle between the force and the displacement. In symbols: $W = F \Delta x \cos \theta$
Positive work	The kinetic energy of the object increases.
Negative work	The kinetic energy of the object decreases.
Work-energy theorem	The net/total work done on an object is equal to the change in the object's kinetic energy OR the work done on an object by a resultant/net force is equal to the change in the object's kinetic energy. In symbols: $W_{\text{net}} = \Delta K = K_f - K_i$.
Principle of conservation of mechanical energy	The total mechanical energy (sum of gravitational potential energy and kinetic energy) in an isolated system remains constant. (A system is isolated when the resultant/net external force acting on the system is zero.) In symbols: $E_{M(\text{initial})} = E_{M(\text{final})}$ OR $(E_p + E_k)_{\text{initial}} = (E_p + E_k)_{\text{final}}$
Conservative force	A force for which the work done (in moving an object between two points) is independent of the path taken. Examples are gravitational force, the elastic force in a spring and electrostatic forces (Coulomb forces).
Non-conservative force	A force for which the work done (in moving an object between two points) depends on the path taken. Examples are frictional force, air resistance, tension in a chord, etc.
Power	The rate at which work is done or energy is expended. In symbols: $P = \frac{W}{\Delta t}$ Unit: watt (W)

WAVES, SOUND AND LIGHT: DOPPLER EFFECT	
Doppler Effect	The apparent change in frequency/pitch of the sound detected by a listener because the sound source and the listener have different velocities relative to the medium of sound propagation. OR: The change in frequency/pitch of the sound detected by a listener due to relative motion between the sound source and the listener.
Red shift	Observed when light from an object increased in wavelength (decrease in frequency). A red shift occurs when a light source moves away from an observer.
Blue shift	Observed when light from an object decreased in wavelength (increase in frequency). A blue shift occurs when a light source moves towards an observer.
Frequency	The number of vibrations per second. Symbol: f Unit: hertz (Hz) or per second (s^{-1})
Wavelength	The distance between two successive points in phase. Symbol: λ Unit: meter (m)
Wave equation	Speed = frequency x wavelength

ELECTRICITY AND MAGNETISM: ELECTROSTATICS	
Coulomb's law	The magnitude of the electrostatic force exerted by one point charge on another point charge is directly proportional to the product of the magnitudes of the charges and inversely proportional to the square of the distance between them. In symbols: $F = \frac{kQ_1Q_2}{r^2}$
Electric field	A region of space in which an electric charge experiences a force.
Electric field at a point	The electric field at a point is the electrostatic force experienced per unit positive charge placed at that point. In symbols: $E = \frac{F}{q}$ Unit: $N \cdot C^{-1}$
Direction of electric field	The direction of the electric field at a point is the direction that a positive test charge would move if placed at that point.

ELECTRICITY AND MAGNETISM: ELECTRIC CIRCUITS	
Ohm's law	The potential difference across a conductor is directly proportional to the current in the conductor at constant temperature. In symbols: $R = \frac{V}{I}$
Ohmic conductors	A conductor that obeys Ohm's law i.e the ratio of potential difference to current remains constant. (Resistance of the conductor remains constant.)
Non-ohmic conductors	A conductor that does not obey Ohm's law i.e the ratio of potential difference to current does NOT remain constant. (Resistance of the conductor increases as the current increases e.g. a bulb.)
Power	Rate at which work is done. In symbols: $P = \frac{W}{\Delta t}$ Unit: watt (W) Other formulae: $P = VI$; $P = I^2R$; $P = \frac{V^2}{R}$
kilowatt hour (kWh)	The use of 1 kilowatt of electricity for 1 hour.
Internal resistance	The resistance within a battery that causes a drop in the potential difference of the battery when there is a current in the circuit.
emf	Maximum energy provided (work done) by a battery per coulomb/unit charge passing through it. (It is the potential difference across the ends of a battery when there is NO current in the circuit.)

Terminal potential difference	The energy transferred to or the work done per coulomb of charge passing through the battery when the battery delivers a current. (It is the potential difference across the ends of a battery when there is a current in the circuit.)
-------------------------------	--

ELECTRICITY AND MAGNETISM: ELECTRICAL MACHINES

Generator	A device that transfers mechanical energy into electrical energy.
Faraday's law of electromagnetic induction	The magnitude of the induced emf across the ends of a conductor is directly proportional to the rate of change in the magnetic flux linkage with the conductor. (When a conductor is moved in magnetic field, a potential difference is induced across the conductor.)
Fleming's Right Hand Rule for generators	Hold the thumb, forefinger and second finger of the RIGHT hand at right angles to each other. If the forefinger points in the direction of the magnetic field (N to S) and the thumb points in the direction of the force (movement), then the second finger points in the direction of the induced current.
Electric motor	A device that transfers electrical energy into mechanical energy.
Fleming's Left Hand Rule for electric motors	Hold the thumb, forefinger and second finger of the LEFT hand at right angles to each other. If the forefinger points in the direction of the magnetic field (N to S) and the second finger points in the direction of the conventional current, then the thumb will point in the direction of the force (movement).
Conventional current	Flow of electric charge from positive to negative.
AC	Alternating current The direction of the current changes each half cycle.
DC	Direct current The direction of the current remains constant. (The direction of conventional current is from the positive to the negative pole of a battery. The direction of electron current is from the negative to the positive pole of the battery.)
Root-mean-square potential difference (V_{rms})	The root-mean-square potential difference is the AC potential difference that dissipates the same amount of energy (gives the same heating effect) as an equivalent DC potential difference.
Peak potential difference (V_{max})	The maximum potential difference value reached by the alternating current as it fluctuates i.e. the peak of the sine wave representing an AC potential difference.
Root-mean-square current (I_{rms})	Root-mean-square current is the alternating current that dissipates the same amount of energy (gives the same heating effect) as and equivalent DC current.
Peak current (I_{max})	The maximum current value reached by the alternating current as it fluctuates i.e. the peak of the sine wave representing an AC current.

MATTER AND MATERIALS: OPTICAL PHENOMENA AND PROPERTIES OF MATERIALS

Photo-electric effect	The process whereby electrons are ejected from a metal surface when light of suitable frequency is incident on that surface.
Threshold frequency (f_0)	The minimum frequency of light needed to emit electrons from a certain metal surface.
Work function (W_0)	The minimum energy that an electron in the metal needs to be emitted from the metal surface.
Photo-electric equation	$E = W_0 + K_{max}$, where $E = hf$ and $W_0 = hf_0$ and $K_{max} = \frac{1}{2}mv_{max}^2$
Atomic absorption spectrum	Formed when certain frequencies of electromagnetic radiation that passes through a medium, e.g. a cold gas, is absorbed.
Atomic emission spectrum	Formed when certain frequencies of electromagnetic radiation are emitted due to an atom's electrons making a transition from a high-energy state to a lower energy state.

QUESTIONS

NEWTON'S LAWS

QUESTION 1

Two blocks of masses 20 kg and 5 kg respectively are connected by a light inextensible string, **P**. A second light inextensible string, **Q**, attached to the 5 kg block, runs over a light frictionless pulley. A constant horizontal force of 250 N pulls the second string as shown in the diagram below. The magnitudes of the tensions in **P** and **Q** are T_1 and T_2 respectively. Ignore the effects of air friction.

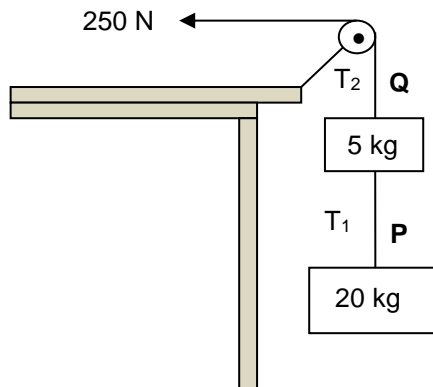

- 1.1 State Newton's second law of motion in words. (2)
 - 1.2 Draw a labelled free-body diagram indicating ALL the forces acting on the **5 kg block**. (3)
 - 1.3 Calculate the magnitude of the tension T_1 in string **P**. (6)
 - 1.4 When the 250 N force is replaced by a sharp pull on the string, one of the two strings break. Which ONE of the two strings, **P** or **Q**, will break? (1)
- [12]**

QUESTION 2

A block of mass 1 kg is connected to another block of mass 4 kg by a light inextensible string. The system is pulled up a rough plane inclined at 30° to the horizontal, by means of a constant 40 N force parallel to the plane as shown in the diagram below.

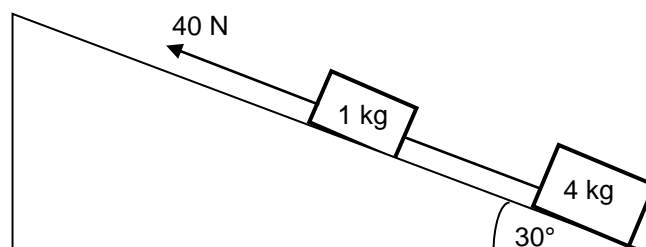

The magnitude of the kinetic frictional force between the surface and the 4 kg block is 10 N. The coefficient of kinetic friction between the 1 kg block and the surface is 0,29.

- 2.1 State Newton's third law of motion in words. (2)
 - 2.2 Draw a labelled free-body diagram showing ALL the forces acting on the **1 kg block** as it moves up the incline. (5)
 - 2.3 Calculate the magnitude of the:
 - 2.3.1 Kinetic frictional force between the 1 kg block and the surface (3)
 - 2.3.2 Tension in the string connecting the two blocks (6)
- [16]**

QUESTION 3

A 5 kg block, resting on a rough horizontal table, is connected by a light inextensible string passing over a light frictionless pulley to another block of mass 2 kg. The 2 kg block hangs vertically as shown in the diagram below.

A force of 60 N is applied to the 5 kg block at an angle of 10° to the horizontal, causing the block to accelerate to the left.

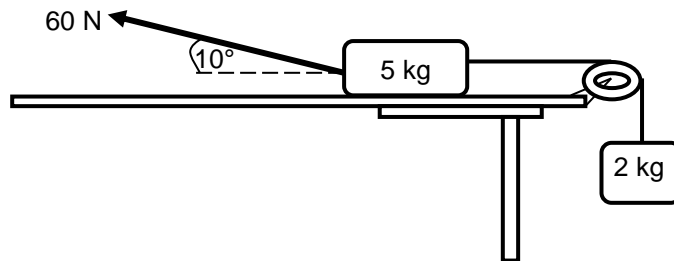

The coefficient of kinetic friction between the 5 kg block and the surface of the table is 0,5. Ignore the effects of air friction.

- 3.1 Draw a labelled free-body diagram showing ALL the forces acting on the 5 kg block. (5)
- 3.2 Calculate the magnitude of the:
- 3.2.1 Vertical component of the 60 N force (2)
- 3.2.2 Horizontal component of the 60 N force (2)
- 3.3 State Newton's Second Law of Motion in words. (2)
- Calculate the magnitude of the:
- 3.4 Normal force acting on the 5 kg block (2)
- 3.5 Tension in the string connecting the two blocks (7)

[20]**QUESTION 4**

- 4.1 Two blocks of mass M kg and 2,5 kg respectively are connected by a light, inextensible string. The string runs over a light, frictionless pulley, as shown in the diagram below. The blocks are **stationary**.

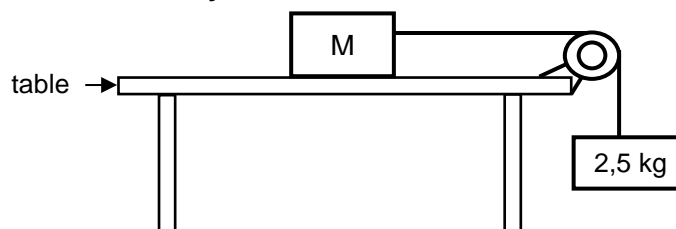

- 4.1.1 State Newton's THIRD law of motion in words. (2)
- 4.1.2 Calculate the tension in the string. (3)
- The coefficient of static friction (μ_s) between the unknown mass M and the surface of the table is 0,2.
- 4.1.3 Calculate the minimum value of M that will prevent the blocks from moving. (5)
- The block of unknown mass M is now replaced with a block of mass 5 kg. The 2,5 kg block now accelerates downwards. The coefficient of kinetic friction (μ_k) between the 5 kg block and the surface of the table is 0,15.
- 4.1.4 Calculate the magnitude of the acceleration of the 5 kg block. (5)
- 4.2 A small hypothetical planet **X** has a mass of $6,5 \times 10^{20}$ kg and a radius of 550 km. Calculate the gravitational force (weight) that planet **X** exerts on a 90 kg rock on this planet's surface. (4)

[19]

QUESTION 5

- 5.1 A 5 kg mass and a 20 kg mass are connected by a light inextensible string which passes over a light frictionless pulley. Initially, the 5 kg mass is held stationary on a horizontal surface, while the 20 kg mass hangs vertically downwards, 6 m above the ground, as shown in the diagram, not drawn to scale.

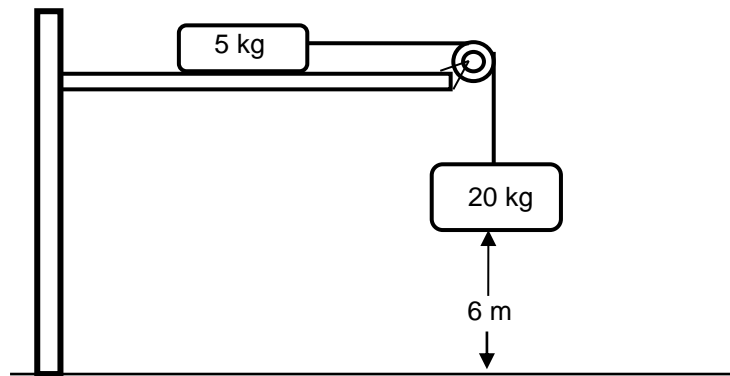

When the *stationary* 5 kg mass is released, the two masses begin to move. The coefficient of kinetic friction, μ_k , between the 5 kg mass and the horizontal surface is 0,4. Ignore the effects of air friction.

- 5.1.1 Calculate the acceleration of the 20 kg mass. (5)
- 5.1.2 Calculate the speed of the 20 kg mass as it strikes the ground. (4)
- 5.1.3 At what minimum distance from the pulley should the 5 kg mass be placed initially, so that the 20 kg mass just strikes the ground? (1)
- 5.2 A person of mass 60 kg climbs to the top of a mountain which is 6 000 m above ground level.

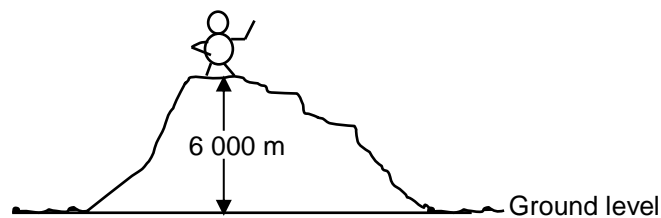

- 5.2.1 State Newton's Law of Universal Gravitation in words. (2)
- 5.2.2 Calculate the *difference* in the weight of the climber at the top of the mountain and at ground level. (6)

[18]**QUESTION 6**

The diagram below shows a 10 kg block lying on a flat, rough, horizontal surface of a table. The block is connected by a light, inextensible string to a 2 kg block hanging over the side of the table. The string runs over a light, frictionless pulley. The blocks are **stationary**.

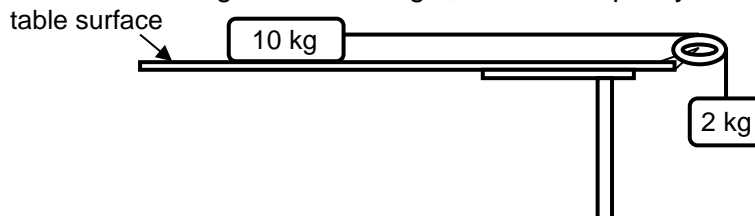

- 6.1 State Newton's FIRST law of motion in words. (2)
- 6.2 Write down the magnitude of the NET force acting on the 10 kg block. (1)

When a 15 N force is applied vertically downwards on the 2 kg block, the 10 kg block accelerates to the right at $1,2 \text{ m}\cdot\text{s}^{-2}$.

- 6.3 Draw a free-body diagram for the 2 kg block when the 15 N force is applied to it. (3)
- 6.4 Calculate the coefficient of kinetic friction between the 10 kg block and the surface of the table. (7)

- 6.5 How does the value, calculated in QUESTION 6.4, compare with the value of the coefficient of STATIC friction for the 10 kg block and the table? Write down only LARGER THAN, SMALLER THAN or EQUAL TO. (1)
- 6.6 If the 10 kg block had a larger surface area in contact with the surface of the table, how would this affect the coefficient of kinetic friction calculated in QUESTION 6.4? Assume that the rest of the system remains unchanged. Write down only INCREASES, DECREASES or REMAINS THE SAME. Give a reason for the answer. (2)

[16]**QUESTION 7**

A learner constructs a push toy using two blocks with masses 1,5 kg and 3 kg respectively. The blocks are connected by a massless, inextensible cord. The learner then applies a force of 25 N at an angle of 30° to the 1,5 kg block by means of a light rigid rod, causing the toy to move across a flat, rough, horizontal surface, as shown in the diagram.

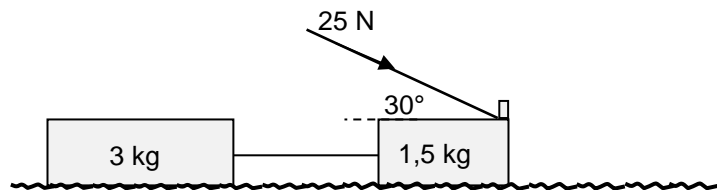

The coefficient of kinetic friction (μ_k) between the surface and each block is 0,15.

- 7.1 State Newton's Second Law of Motion in words. (2)
- 7.2 Calculate the magnitude of the kinetic frictional force acting on the 3 kg block. (3)
- 7.3 Draw a labelled free-body diagram showing ALL the forces acting on the 1,5 kg block. (5)
- 7.4 Calculate the magnitude of the:
- 7.4.1 Kinetic frictional force acting on the 1,5 kg block (3)
- 7.4.2 Tension in the cord connecting the two blocks (5)

[18]**QUESTION 8**

- 8.1 A crate of mass 2 kg is being pulled to the right across a rough horizontal surface by constant force **F**. The force **F** is applied at an angle of 20° to the horizontal, as shown in the diagram.

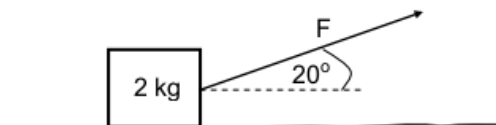

- 8.1.1 Draw a labelled free-body diagram showing ALL the forces acting on the crate. (4)

A constant frictional force of 3 N acts between the surface and the crate. The coefficient of kinetic friction between the crate and the surface is 0,2.

Calculate the magnitude of the:

- 8.1.2 Normal force acting on the crate (3)
- 8.1.3 Force **F** (4)
- 8.1.4 Acceleration of the crate (3)
- 8.2 A massive rock from outer space is moving towards the Earth.
- 8.2.1 State Newton's Law of Universal Gravitation in words. (2)
- 8.2.2 How does the magnitude of the gravitational force exerted by the Earth on the rock change as the distance between the rock and the Earth becomes smaller? Choose from INCREASES, DECREASES or REMAINS THE SAME. Give a reason for the answer. (2)

[18]

QUESTION 9

In the diagram below, a small object of mass 2 kg is sliding at a constant velocity of $1,5 \text{ m}\cdot\text{s}^{-1}$ down a rough plane inclined at 7° to the horizontal surface.

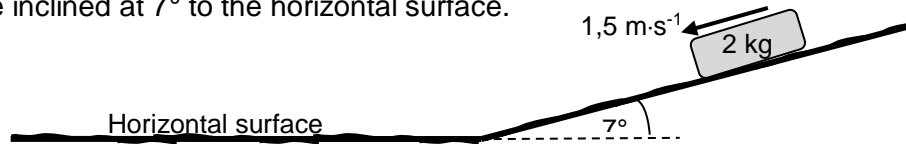

At the bottom of the plane, the object continues sliding onto the rough horizontal surface *and eventually comes to a stop*. The coefficient of kinetic friction between the object and the surface is *the same for both the inclined surface and the horizontal surface*.

- 9.1 Write down the magnitude of the net force acting on the object. (1)
- 9.2 Draw a labelled free-body diagram for the object while it is on the inclined plane. (3)
- 9.3 Calculate the:
- 9.3.1 Magnitude of the frictional force acting on the object while it is sliding down the inclined plane (3)
- 9.3.2 Coefficient of kinetic friction between the object and the surfaces (3)
- 9.3.3 Distance the object travels on the horizontal surface before it comes to a stop (5)
- [15]**

QUESTION 10

- 10.1 An 8 kg block, **P**, is being pulled by constant force **F** up a rough inclined plane at an angle of 30° to the horizontal, at **CONSTANT SPEED**. Force **F** is parallel to the inclined plane, as shown in the diagram.

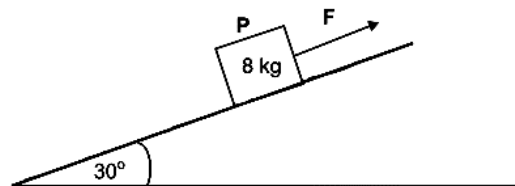

- 10.1.1 State Newton's First Law in words. (2)
- 10.1.2 Draw a labelled free-body diagram for block **P**. (4)
- The kinetic frictional force between the block and the surface of the inclined plane is 20,37 N.
- 10.1.3 Calculate the magnitude of force **F**. (5)
- Force **F** is now removed and the block **ACCELERATES** down the plane. The kinetic frictional force remains 20,37 N.
- 10.1.4 Calculate the magnitude of the acceleration of the block. (4)
- 10.2 A 200 kg rock lies on the surface of a planet. The acceleration due to gravity on the surface of the planet is $6,0 \text{ m}\cdot\text{s}^{-2}$.
- 10.2.1 State Newton's Law of Universal Gravitation in words. (2)
- 10.2.2 Calculate the mass of the planet if its radius is 700 km. (4)
- [21]**

QUESTION 11

Two boxes, **P** and **Q**, resting on a rough horizontal surface, are connected by a light inextensible string. The boxes have masses 5 kg and 2 kg respectively. A constant force **F**, acting at an angle of 30° to the horizontal, is applied to the 5 kg box, as shown. The two boxes now move to the right at a **constant speed** of $2 \text{ m}\cdot\text{s}^{-1}$.

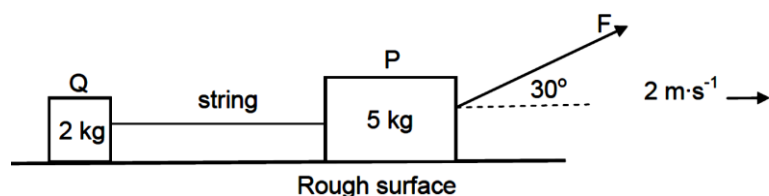

- 11.1 State Newton's First Law of Motion in words. (2)

11.2 Draw a labelled free-body diagram for box **Q**. (4)

Box **P** experiences a constant frictional force of 5 N and box **Q** a constant frictional force of 3 N.

11.3 Calculate the magnitude of force **F**. (6)

The string connecting **P** and **Q** suddenly breaks after 3 s while force **F** is still being applied.

Learners draw the velocity-time graph for the motion of **P** and **Q** before and after the string breaks, as shown alongside.

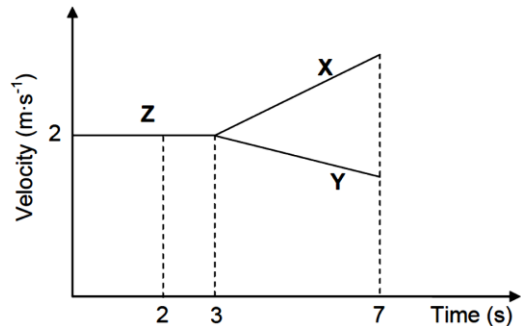

11.4 Write down the time at which the string breaks. (1)

11.5 Which portion (**X**, **Y** or **Z**) of the graph represents the motion of box **Q**, after the string breaks? Use the information in the graph to fully support the answer. (4) [17]

QUESTION 12

Block **P**, of unknown mass, is placed on a rough horizontal surface. It is connected to a second block of mass 3 kg, by a light inextensible string passing over a light, frictionless pulley, as shown. Initially the system of masses is held stationary with the 3 kg block, 0,5 m above the ground. When the system is released the 3 kg block moves vertically downwards and strikes the ground after 3 s. Ignore the effects of air resistance.

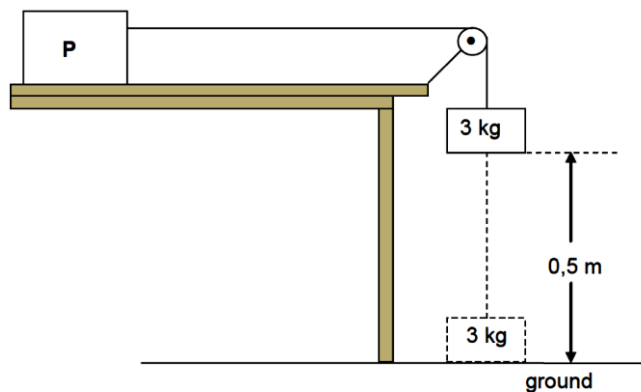

12.1 Define the term *acceleration* in words. (2)

12.2 Calculate the magnitude of the acceleration of the 3 kg block using equations of motion. (3)

12.3 Calculate the magnitude of the tension in the string. (3)

The magnitude of the kinetic frictional force experienced by block **P** is 27 N.

12.4 Draw a labelled free-body diagram for block **P**. (4)

12.5 Calculate the mass of block **P**. (3) [15]

QUESTION 13

A block, of mass 8 kg, is placed on a rough horizontal surface. The 8 kg block, which is connected to a 2 kg block by means of a light inextensible string passing over a light frictionless pulley, starts sliding from point **A**, as shown.

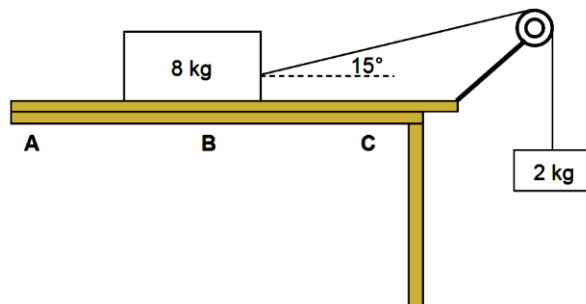

13.1 State Newton's Second Law in words. (2)

13.2 Draw a labelled free-body diagram for the 8 kg block. (4)

13.3 When the 8 kg block reaches point **B**, the angle between the string and the horizontal is 15° and the acceleration of the system is 1,32 m·s⁻².

13.3.1 Give a reason why the system is NOT in equilibrium. (1)

- 13.3.2 Use the 2 kg mass to calculate the tension in the string. (3)
- 13.3.3 Calculate the kinetic frictional force between the 8 kg block and the horizontal surface. (4)
- 13.4 As the 8 kg block moves from **B** to **C**, the kinetic frictional force between the 8 kg block and the horizontal surface is not constant. Give a reason for this statement. (1)
- The horizontal surface on which the 8 kg block is moving, is replaced by another horizontal surface made from a different material.
- 13.5 Will the kinetic frictional force, calculated in QUESTION 13.3.3 above, change? Choose from: YES or NO. Give a reason for the answer. (2)

[17]

VERTICAL PROJECTILE MOTION

QUESTION 1

A ball, **A**, is thrown vertically upward from a height, h , with a speed of $15 \text{ m}\cdot\text{s}^{-1}$. AT THE SAME INSTANT, a second identical ball, **B**, is dropped from the same height as ball **A** as shown in the diagram below. Both balls undergo free fall and eventually hit the ground.

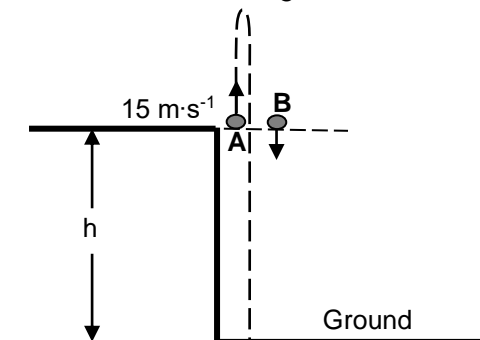

- 1.1 Explain the term *free fall*. (2)
- 1.2 Calculate the time it takes for ball **A** to return to its starting point. (4)
- 1.3 Calculate the distance between ball **A** and ball **B** when ball **A** is at its maximum height. (7)

- 1.4 Sketch a velocity-time graph in the ANSWER BOOK for the motion of ball **A** from the time it is projected until it hits the ground. Clearly show the following on your graph:
- The initial velocity
 - The time it takes to reach its maximum height
 - The time it takes to return to its starting point

(4)
[17]

QUESTION 2

An object is released from rest from a point **X**, above the ground as shown in the diagram below. It travels the last 30 m (**BC**) in 1,5 s before hitting the ground. Ignore the effects of air friction.

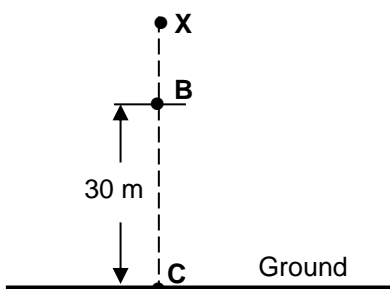

- 2.1 Name the type of motion described above. (1)
- 2.2 Calculate the magnitude of the velocity of the object at point **B**. (4)
- 2.3 Calculate the height of point **X** above the ground. (5)
- After hitting the ground, the object bounces once and then comes to rest on the ground.

- 2.3 Sketch an acceleration-time graph for the entire motion of the object. (3)

[17]

QUESTION 3

A hot air balloon is rising vertically at a constant velocity. When the hot air balloon reaches point **A** a few metres above the ground, a man in the hot air balloon drops a ball which hits the ground and bounces. Ignore the effects of friction.

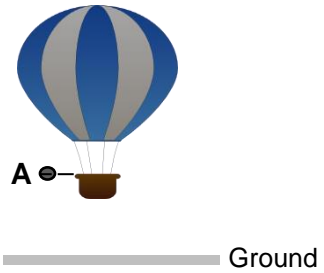

The velocity-time graph below represents the motion of the ball from the instant it is dropped until after it bounces for the first time. The time interval between bounces is ignored. THE UPWARD DIRECTION IS TAKEN AS POSITIVE. USE INFORMATION FROM THE GRAPH TO ANSWER THE QUESTIONS THAT FOLLOW.

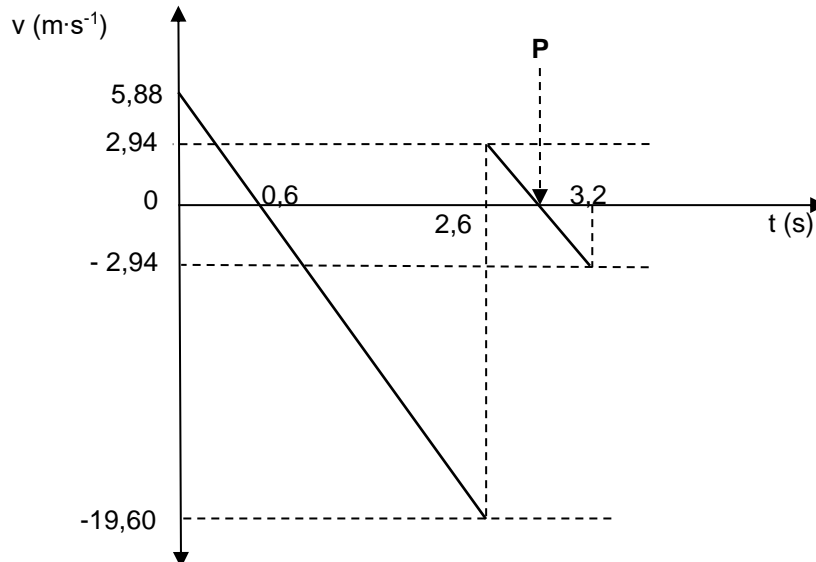

- 3.1 Write down the magnitude of the velocity of the hot air balloon. (1)
 - 3.2 Calculate the height above the ground from which the ball was dropped. (3)
 - 3.3 Calculate the time at the point **P** indicated on the graph (2)
 - 3.4 Calculate the maximum height the ball reaches after the first bounce (3)
 - 3.5 Calculate the distance between the ball and hot air balloon when the ball is at its maximum height after the first bounce (4)
- [13]**

QUESTION 4

Ball **A** is projected vertically upwards at a velocity of $16 \text{ m}\cdot\text{s}^{-1}$ from the ground. Ignore the effects of air resistance. **Use the ground as zero reference.**

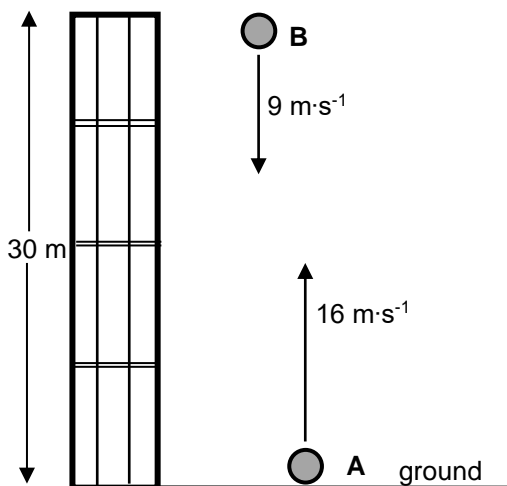

- 4.1 Calculate the time taken by ball **A** to return to the ground. (4)
- 4.2 Sketch a velocity-time graph for ball **A**. Show the following on the graph:
 - (a) Initial velocity of ball **A**
 - (b) Time taken to reach the highest point of the motion
 - (c) Time taken to return to the ground (3)

ONE SECOND after ball **A** is projected upwards, a second ball, **B**, is thrown vertically downwards at a velocity of $9 \text{ m}\cdot\text{s}^{-1}$ from a balcony 30 m above the ground. Refer to the diagram.

- 4.3 Calculate how high above the ground ball **A** will be at the instant the two balls pass each other. (6)
- [13]**

QUESTION 5

A man throws ball **A** downwards with a speed of $2 \text{ m}\cdot\text{s}^{-1}$ from the edge of a window, 45 m above a dam of water. One second later he throws a second ball, ball **B**, downwards and observes that both balls strike the surface of the water in the dam at the same time. Ignore air friction.

- 5.1 Calculate the:
- 5.1.1 Speed with which ball **A** hits the surface of the water (3)
- 5.1.2 Time it takes for ball **B** to hit the surface of the water (3)
- 5.1.3 Initial velocity of ball **B** (5)
- 5.2 On the same set of axes, sketch a velocity versus time graph for the motion of balls **A** and **B**. Clearly indicate the following on your graph:
- Initial velocities of both balls **A** and **B**
 - The time of release of ball **B**
 - The time taken by both balls to hit the surface of the water (5)
- [16]

QUESTION 6

Ball **A** is projected vertically upwards from the ground, near a tall building, with a speed of $30 \text{ m}\cdot\text{s}^{-1}$. Ignore the effects of air friction.

- 6.1 Explain what is meant by a *projectile*. (2)
- 6.2 Calculate the total time that ball **A** will be in the air. (4)
- 6.3 Calculate the distance travelled by ball **A** during the last second of its fall. (4)

- 6.4 TWO SECONDS after ball **A** is projected upwards, ball **B** is projected vertically upwards from the roof of the same building. The roof the building is 50 m above the ground. Both balls **A** and **B** reach the ground *at the same time*. Refer to the diagram. Ignore the effects of air friction.

Calculate the speed with which ball **B** was projected upwards from the roof.

(4)

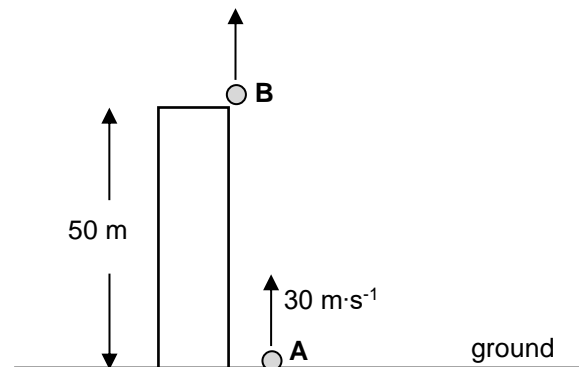

- 6.5 Sketch velocity-time graphs for the motion of both balls **A** and **B** on the *same set of axes*. Clearly label the graphs for balls **A** and **B** respectively. Indicate the following on the graphs:

- (a) Time taken by both balls **A** and **B** to reach the ground
- (b) Time taken by ball **A** to reach its maximum height

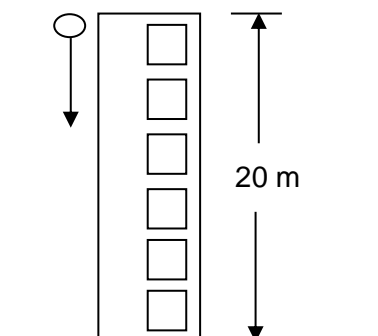
(4)
[18]**QUESTION 7**

A ball is dropped from the top of a building 20 m high. Ignore the effects of air resistance.

- 7.1 Define the term *free fall*. (4)
- 7.2 Calculate the speed at which the ball hits the ground (4)
- 7.3 Calculate the time it takes the ball to reach the ground (3)
- 7.4 Sketch a velocity-time graph for the motion of the ball (no values required). (2)

[11]

QUESTION 8

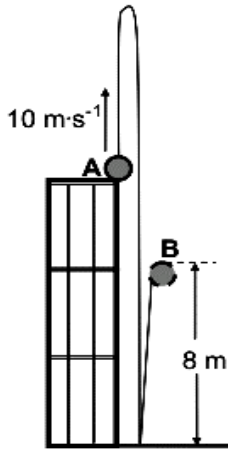

A ball is projected vertically upwards with a speed of $10 \text{ m}\cdot\text{s}^{-1}$ from point **A**, which is at the top edge of a building. The ball hits the ground after 3 s. It is in contact with the ground for 0,2 s and then bounces vertically upwards, reaching a maximum height of 8 m at point **B**. See the diagram below. Ignore the effects of friction.

- 8.1 Why is the ball considered to be in free fall during its motion? (2)
- 8.2 Calculate the:
 - 8.2.1 Height of the building (3)
 - 8.2.2 Speed with which the ball hits the ground (3)
 - 8.2.3 Speed with which the ball leaves the ground (3)

- 8.3 Draw a velocity versus time graph for the complete motion of the ball from **A** to **B**. Show the following on the graph:
 - The magnitude of the velocity with which it hits the ground
 - The magnitude of the velocity with which it leaves the ground
 - The time taken to reach the ground, as well as the time at which it leaves the ground

(4)
[15]

QUESTION 9

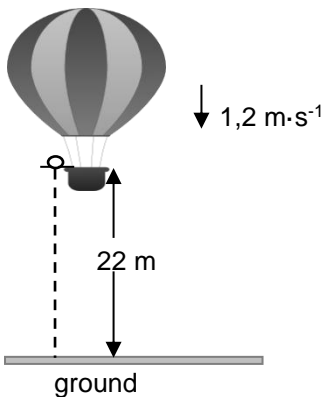

A hot-air balloon moves vertically downwards at a constant velocity of $1,2 \text{ m}\cdot\text{s}^{-1}$. When it reaches a height of 22 m from the ground, a ball is dropped from the balloon. Refer to the diagram.

Assume that the dropping of the ball has no effect on the speed of the hot-air balloon. Ignore air friction for the motion of the ball.

- 9.1 Explain the term *projectile motion*. (2)
- 9.2 Is the hot-air balloon in free fall? Give a reason for the answer. (2)
- 9.3 Calculate the time it takes for the ball to hit the ground after it is dropped. (4)

When the ball lands on the ground, it is in contact with the ground for 0,3 s and then it bounces vertically upwards with a speed of $15 \text{ m}\cdot\text{s}^{-1}$.

- 9.4 Calculate how high the balloon is from the ground when the ball reaches its maximum height after the first bounce. (6)

[14]

QUESTION 10

Stone **A** is projected vertically upwards at a speed of $12 \text{ m}\cdot\text{s}^{-1}$ from a height h above the ground. Ignore the effects of air resistance.

- 10.1 Calculate the time taken for stone **A** to reach its maximum height. (3)

At the same instant that stone **A** is projected upwards, stone **B** is thrown vertically downwards from the same height at an unknown speed, v . Refer to the diagram. When stone **A** reaches its maximum height, the speed of stone **B** is $3v$.

- 10.2 Calculate the speed, v , with which stone **B** is thrown downwards. (4)

At the instant stone **A** passes its initial position on its way down, stone **B** hits the ground.

- 10.3 Calculate the height h . (3)

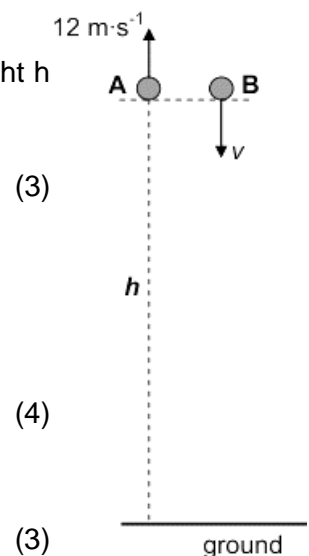

10.4 Sketch velocity-time graphs for the complete motions of stones **A** and **B** on the same set of axes. Label your graphs for stones **A** and **B** clearly.

Show the following on the graphs:

- The time taken for stone A to reach its maximum height
- The velocity with which stone B is thrown downwards

(4)
[14]

QUESTION 11

A ball is thrown **vertically downwards** from the top of a building and bounces a few times as it hits the ground. The velocity-time graph below describes the motion of the ball from the time it is thrown, up to a certain time **T**. Take downwards as the positive direction and the ground as zero reference. The graph is NOT drawn to scale. The effects of air friction are ignored.

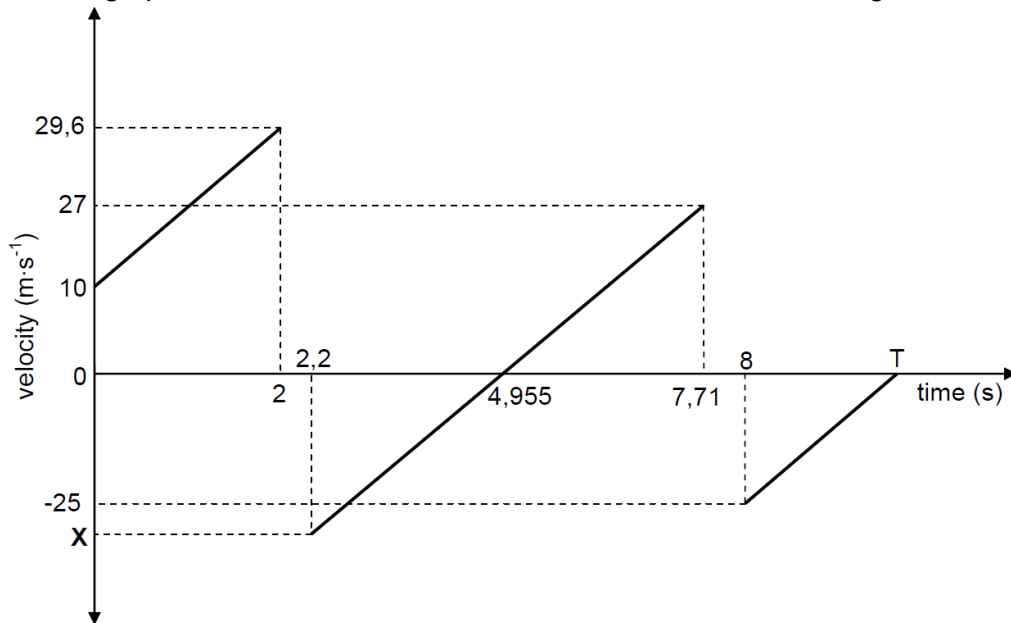

- 11.1 Write down the speed with which the ball is thrown downwards. (1)
- 11.2 ALL parts of the graph have the same gradient. Give a reason for this. (2)
- 11.3 Calculate the height from which the ball is thrown. (3)
- 11.4 Calculate the time (**T**) shown on the graph. (4)
- 11.5 Write down the:
- 11.5.1 Time that the ball is in contact with the ground at the first bounce (1)
- 11.5.2 Time at which the ball reaches its maximum height after the first bounce (2)
- 11.5.3 Value of **X** (1)
- 11.6 Is the collision of the ball with the ground *elastic* or *inelastic*? Give a reason for the answer using information in the graph. (2)

[16]

QUESTION 12

In the diagram shown, point **A** is at the top of a building. Point **B** is exactly **halfway** between the point **A** and the ground. Ignore air resistance.

12.1 Define the term *free fall*. (2)

A ball of mass 0,4 kg is dropped from point **A**. It passes point **B** after 1 s.

12.2 Calculate the height of point **A** above the ground. (3)

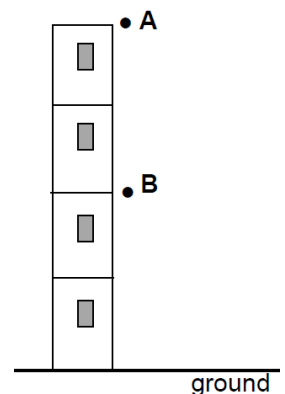

When the ball strikes the ground it is in contact with the ground for 0,2 s and then bounces vertically upwards, reaching a maximum height at point **B**.

12.3 Calculate the magnitude of the velocity of the ball when it strikes the ground. (3)

12.4 Calculate the magnitude of the average net force exerted on the ball while it is in contact with the ground. (6)

[14]

QUESTION 13

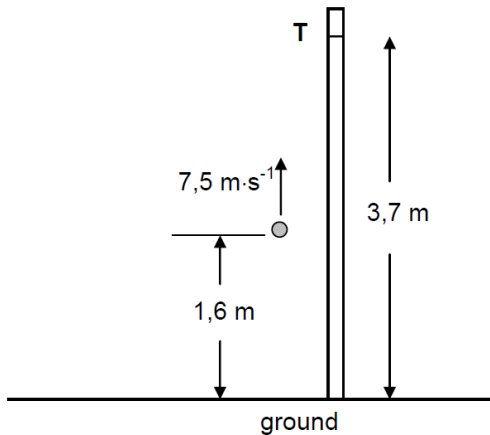

In a competition, participants must attempt to throw a ball vertically upwards past point **T**, marked on a tall vertical pole. Point **T** is 3,7 m above the ground. Point **T** may, or may not, be the highest point during the motion of the ball. One participant throws the ball vertically upwards at a velocity of 7,5 m·s⁻¹ from a point that is 1,6 m above the ground, as shown in the diagram. Ignore the effects of air resistance.

13.1 In which direction is the net force acting on the ball while it moves towards point **T**? Choose from: UPWARDS or DOWNWARDS. Give a reason for the answer. (2)

13.2 Calculate the time taken by the ball to reach its highest point. (3)

13.3 Determine, by means of a calculation, whether the ball will pass point **T** or not. (6)

13.4 Draw a velocity-time graph for the motion of the ball from the instant it is thrown upwards until it reaches its highest point. Indicate the following on the graph:

- The initial velocity and final velocity
- Time taken to reach the highest point

(2)
[13]

MOMENTUM AND IMPULSE

QUESTION 1

Dancers have to learn many skills, including how to land correctly. A dancer of mass 50 kg leaps into the air and lands feet first on the ground. She lands on the ground with a velocity of 5 m·s⁻¹. As she lands, she bends her knees and comes to a complete stop in 0,2 seconds.

1.1 Calculate the momentum with which the dancer reaches the ground. (3)

1.2 Define the term *impulse* of a force. (2)

1.3 Calculate the magnitude of the net force acting on the dancer as she lands. (3)

Assume that the dancer performs the same jump as before but lands without bending her knees.

1.4 Will the force now be GREATER THAN, SMALLER THAN or EQUAL TO the force calculated in QUESTION 1.3? (1)

1.5 Give a reason for the answer to QUESTION 1.4. (3)

[12]

QUESTION 2

Percy, mass 75 kg, rides at $20 \text{ m}\cdot\text{s}^{-1}$ on a quad bike (motorcycle with four wheels) with a mass of 100 kg. He suddenly applies the brakes when he approaches a red traffic light on a wet and slippery road. The wheels of the quad bike lock and the bike slides forward in a straight line. The force of friction causes the bike to stop in 8 s.

- 2.1 Define the concept *momentum* in words. (2)
- 2.2 Calculate the change in momentum of Percy and the bike, from the moment the brakes lock until the bike comes to a stop. (4)
- 2.3 Calculate the average frictional force exerted by the road on the wheels to stop the bike. (4)

[10]**QUESTION 3**

Two stationary steel balls, **A** and **B**, are suspended next to each other by massless, inelastic strings as shown in Diagram 1 below.

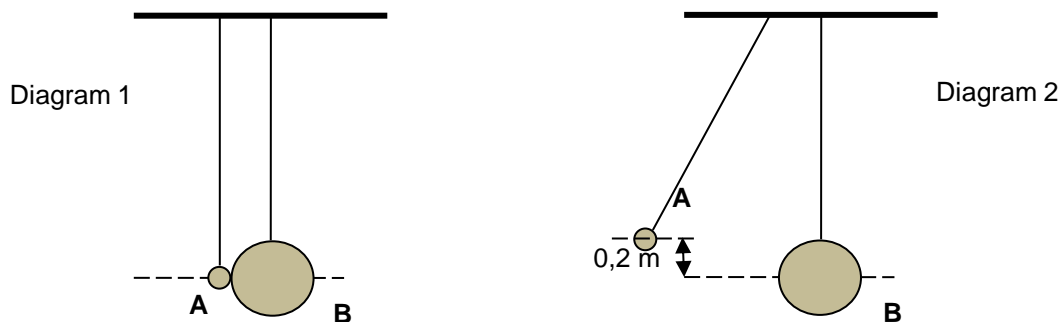

Ball **A** of mass 0,2 kg is displaced through a vertical distance of 0,2 m, as shown in Diagram 2 above. When ball **A** is released, it collides elastically and head-on with ball **B**. Ignore the effects of air friction.

- 3.1 What is meant by an *elastic collision*? (2)

Immediately after the collision, ball **A** moves horizontally backwards (to the left). Ball **B** acquires kinetic energy of 0,12 J and moves horizontally forward (to the right).

Calculate the:

- 3.2 Kinetic energy of ball **A** just before it collides with ball **B** (Use energy principles only.) (3)
- 3.3 Speed of ball **A** immediately after the collision (4)
- 3.4 Magnitude of the impulse on ball **A** during the collision (5)

[14]**QUESTION 4**

A bullet of mass 20 g is fired from a stationary rifle of mass 3 kg. Assume that the bullet moves horizontally. Immediately after firing, the rifle recoils (moves back) with a velocity of $1,4 \text{ m}\cdot\text{s}^{-1}$.

- 4.1 Calculate the speed at which the bullet leaves the rifle. (4)

The bullet strikes a stationary 5 kg wooden block **fixed** to a flat, horizontal table. The bullet is brought to rest after travelling a distance of 0,4 m **into the block**. Refer to the diagram below.

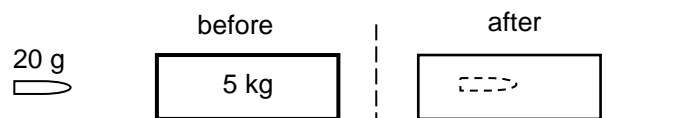

- 4.2 Calculate the magnitude of the average force exerted by the block on the bullet. (5)
- 4.3 How does the magnitude of the force calculated in QUESTION 3.2 compare to the magnitude of the force exerted by the bullet on the block? Write down only LARGER THAN, SMALLER THAN or THE SAME. (1)

[10]

QUESTION 5

The diagram shows two trolleys, **P** and **Q**, held together by means of a compressed spring on a flat, frictionless horizontal track. The masses of **P** and **Q** are 400 g and 600 g respectively.

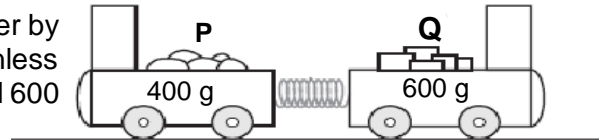

When the trolleys are released, it takes 0,3 s for the spring to unwind to its natural length. Trolley **Q** then moves to the right at 4 m·s⁻¹.

- 5.1 State the *principle of conservation of linear momentum* in words. (2)
 - 5.2 Calculate the:
 - 5.2.1 Velocity of trolley **P** after the trolleys are released (4)
 - 5.2.2 Magnitude of the average force exerted by the spring on trolley **Q** (4)
 - 5.3 Is this an elastic collision? Only answer YES or NO. (1)
- [11]**

QUESTION 6

The diagram below shows two sections, **XY** and **YZ**, of a horizontal, flat surface. Section **XY** is smooth, while section **YZ** is rough. A 5 kg block, moving with a velocity of 4 m·s⁻¹ to the right, collides head-on with a stationary 3 kg block. After the collision, the two blocks stick together and move to the right, past point **Y**. The combined blocks travel for 0,3 s from point **Y** before coming to a stop at point **Z**.

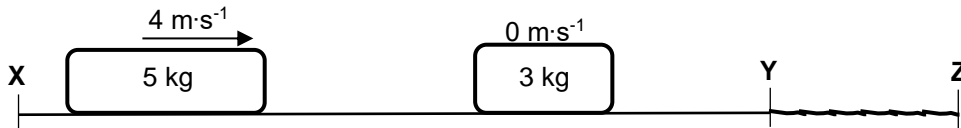

- 6.1 State the *principle of conservation of linear momentum* in words. (2)
 - 6.2 Calculate the magnitude of the:
 - 6.2.1 Velocity of the combined blocks at point **Y** (4)
 - 6.2.2 Net force acting on the combined blocks when they move through section **YZ** (4)
- [10]**

QUESTION 7

The graph below shows how the momentum of car **A** changes with time *just before* and *just after* a head-on collision with car **B**. Car **A** has a mass of 1 500 kg, while the mass of car **B** is 900 kg. Car **B** was travelling at a constant velocity of 15 m·s⁻¹ west before the collision. Take east as positive and consider the system as isolated.

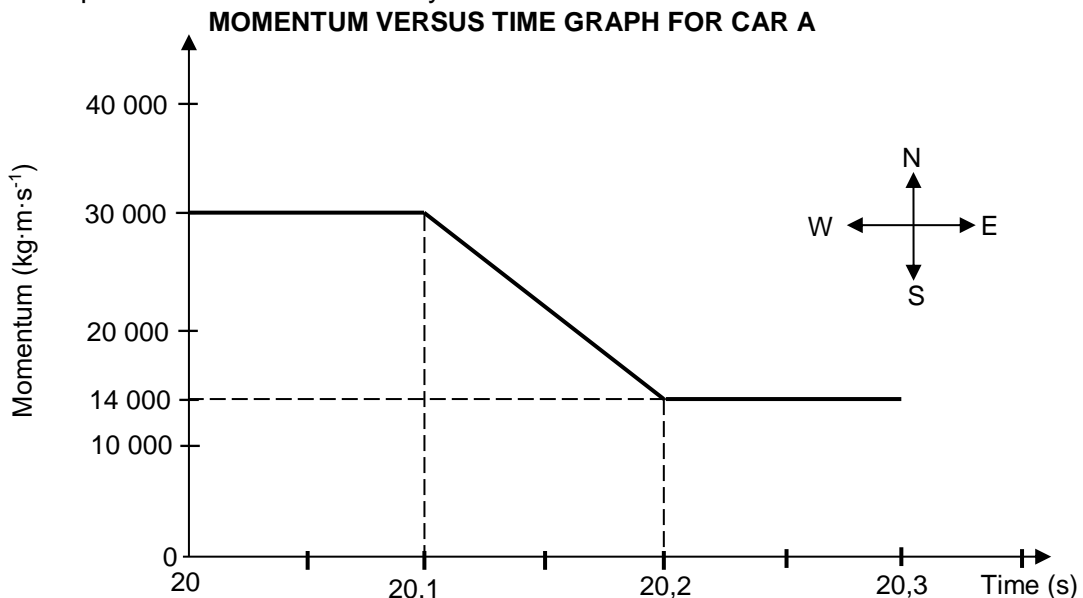

- 7.1 What do you understand by the term *isolated system* as used in physics? (1)

Use the information in the graph to answer the following questions.

- 7.2 Calculate the:
- 7.2.1 Magnitude of the velocity of car **A** just before the collision (3)
 - 7.2.2 Velocity of car **B** just after the collision (5)
 - 7.2.3 Magnitude of the net average force acting on car **A** during the collision (4)
- [13]**

QUESTION 8

A teacher demonstrates the principle of conservation of linear momentum using two trolleys. The teacher first places the trolleys, **A** and **B**, some distance apart on a flat frictionless horizontal surface, as shown in the diagram. The mass of trolley **A** is 3,5 kg and that of trolley **B** is 6,0 kg.



Trolley **A** moves towards trolley **B** at constant velocity. The table below shows the position of trolley **A** for time intervals of 0,4 s before it collides with trolley **B**.

RELATIONSHIP BETWEEN POSITION AND TIME FOR TROLLEY A				
Position of trolley A (m)	0	0,2	0,4	0,6
Time (s)	0	0,4	0,8	1,2

- 8.1 Use the table above to prove that trolley **A** is moving at constant velocity before it collides with trolley **B**. (3)
 - 8.2 State the principle of conservation of linear momentum in words. (2)
- At time $t = 1,2$ s, trolley **A** collides with stationary trolley **B**. The collision time is 0,5 s after which the two trolleys move off together.
- 8.3 Calculate the magnitude of the average net force exerted on trolley **B** by trolley **A**. (6)
- [11]**

QUESTION 9

- 9.1 Define the term *impulse* in words. (2)
- 9.2 The diagram below shows a gun mounted on a mechanical support which is fixed to the ground. The gun is capable of firing bullets rapidly in a horizontal direction. Each bullet travels at a speed of $700 \text{ m}\cdot\text{s}^{-1}$ in an easterly direction when it leaves the gun. (Take the initial velocity of a bullet, before being fired, as zero.)

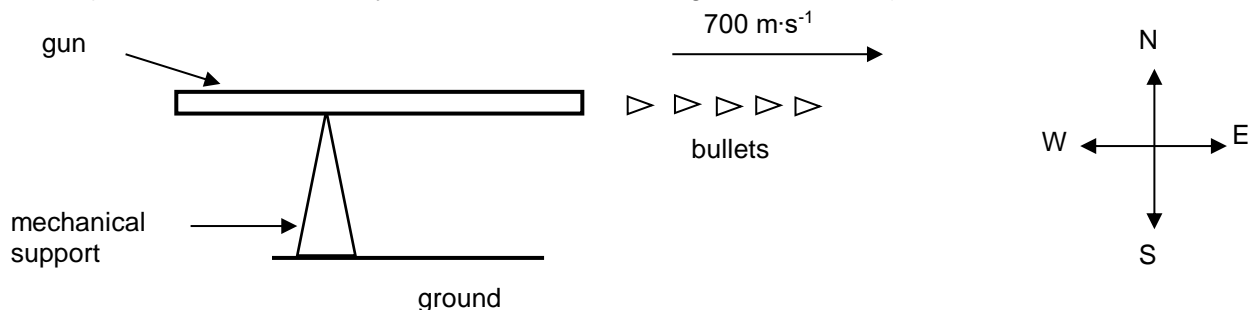

The gun fires 220 bullets per minute. The mass of each bullet is 0,03 kg.

- Calculate the:
- 9.2.1 Magnitude of the momentum of each bullet when it leaves the gun (3)
 - 9.2.2 The net average force that each bullet exerts on the gun (5)
- 9.3 Without any further calculation, write down the net average horizontal force that the mechanical support exerts on the gun. (2)
- [12]**

QUESTION 10

A 2 kg block is at rest on a smooth, frictionless, horizontal table. The length of the block is x . A bullet of mass 0,015 kg, travelling east at $400 \text{ m}\cdot\text{s}^{-1}$, strikes the block and passes straight through it with constant acceleration. Refer to the diagram below. Ignore any loss of mass of the bullet and the block.

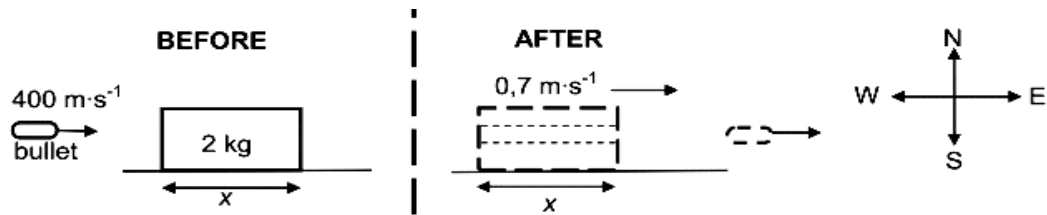

10.1 State the principle of conservation of linear momentum in words. (2)

The block moves eastwards at $0,7 \text{ m}\cdot\text{s}^{-1}$ after the bullet has emerged from it.

10.2 Calculate the magnitude of the velocity of the bullet immediately after it emerges from the block. (4)

10.3 If the bullet takes 0,002 s to travel through the block, calculate the length, x , of the block. (5) [11]

QUESTION 11

The diagram below shows two skateboards, **A** and **B**, initially at rest, with a cat standing on skateboard **A**. The skateboards are in a straight line, one in front of the other and a short distance apart. The surface is flat, frictionless and horizontal.



11.1 State the principle of conservation of linear momentum in words. (2)

EACH skateboard has a mass of 3,5 kg. The cat, of mass 2,6 kg, jumps from skateboard **A** with a horizontal velocity of $3 \text{ m}\cdot\text{s}^{-1}$ and lands on skateboard **B** with the same velocity. Refer to the diagram below.

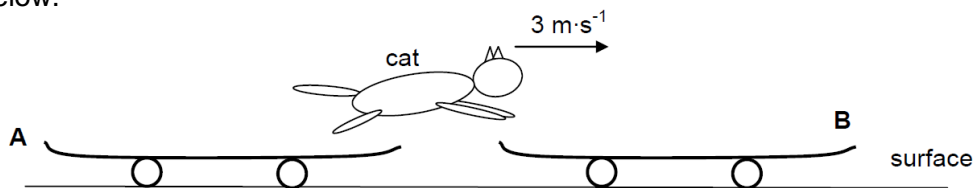

11.2 Calculate the velocity of skateboard **A** just after the cat has jumped from it. (5)

11.3 Immediately after the cat has landed, the cat and skateboard **B** move horizontally to the right at $1,28 \text{ m}\cdot\text{s}^{-1}$. Calculate the magnitude of the impulse on skateboard **B** as a result of the cat's landing. (3) [10]

QUESTION 12

A trolley of mass 1,5 kg is held stationary at point **A** at the top of a frictionless track. When the 1,5 kg trolley is released, it moves down the track. It passes point **P** at the bottom of the incline and collides with a stationary 2 kg trolley at point **B**. Refer to the diagram. Ignore air resistance and rotational effects.

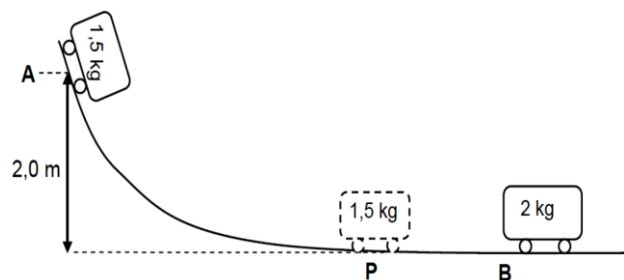

12.1 Use the principle of conservation of mechanical energy to calculate the speed of the 1,5 kg trolley at point **P**. (4)

When the two trolleys collide, they stick together and continue moving with constant velocity.

- 12.2 The principle of conservation of linear momentum is given by the incomplete statement below.
In a/an ... system, the ... linear momentum is conserved.
Rewrite the complete statement and fill in the missing words or phrases. (2)
- 12.3 Calculate the speed of the combined trolleys immediately after the collision. (4)
- 12.4 Calculate the distance travelled by the combined trolleys in 3 s after the collision. (3)
- [13]**

QUESTION 13

Initially a girl on roller skates is at rest on a smooth horizontal pavement. The girl throws a parcel, of mass 8 kg, horizontally to the right at a speed of $4 \text{ m}\cdot\text{s}^{-1}$. Immediately after the parcel has been thrown, the girl-roller-skate combination moves at a speed of $0,6 \text{ m}\cdot\text{s}^{-1}$. Ignore the effects of friction and rotation.

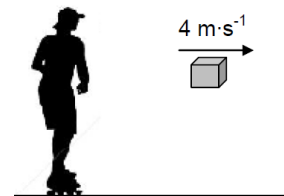

- 13.1 Define the term *momentum* in words. (2)
- 13.2 Will the girl-roller-skate combination move TO THE RIGHT or TO THE LEFT after the parcel is thrown?
NAME the law in physics that can be used to explain your choice of direction. (2)
- The total mass of the roller skates is 2 kg.
- 13.3 Calculate the mass of the girl. (5)
- 13.4 Calculate the magnitude of the impulse that the girl-roller-skate combination is experiencing while the parcel is being thrown. (3)
- 13.5 Without any further calculation, write down the change in momentum experienced by the parcel while it is being thrown. (2)
- [14]**

WORK, ENERGY AND POWER

QUESTION 1

- 1.1 The diagram below shows a track, **ABC**. The curved section, **AB**, is frictionless. The rough horizontal section, **BC**, is 8 m long.

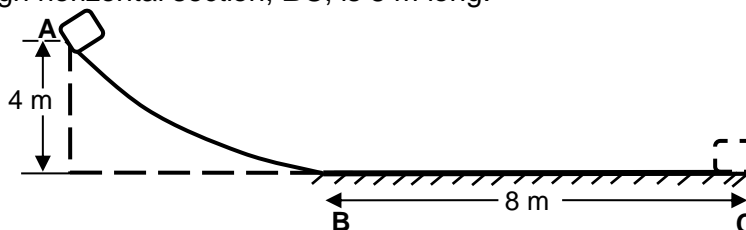

An object of mass 10 kg is released from point **A** which is 4 m above the ground. It slides down the track and comes to rest at point **C**.

- 1.1.1 State the *principle of conservation of mechanical energy* in words. (2)
- 1.1.2 Is mechanical energy conserved as the object slides from **A** to **C**? Write only YES or NO. (1)
- 1.1.3 Using ENERGY PRINCIPLES only, calculate the magnitude of the frictional force exerted on the object as it moves along **BC**. (6)

- 1.2 A motor pulls a crate of mass 300 kg with a constant force by means of a light inextensible rope running over a light frictionless pulley as shown below. The coefficient of kinetic friction between the crate and the surface of the plane is 0,19.

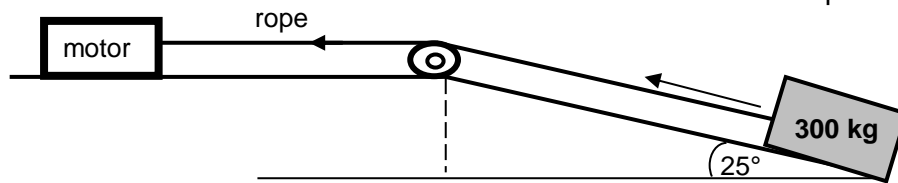

- 1.2.1 Calculate the magnitude of the frictional force acting between the crate and the surface of the inclined plane. (3)

The crate moves up the incline at a constant speed of $0,5 \text{ m}\cdot\text{s}^{-1}$.

- 1.2.2 Calculate the average power delivered by the motor while pulling the crate up the incline. (6)

[18]

QUESTION 2

A 5 kg block is released from rest from a height of 5 m and slides down a frictionless incline to **P** as shown below. It then moves along a frictionless horizontal portion **PQ** and finally moves up a second rough inclined plane. It comes to a stop 3 m above the horizontal at point **R**.

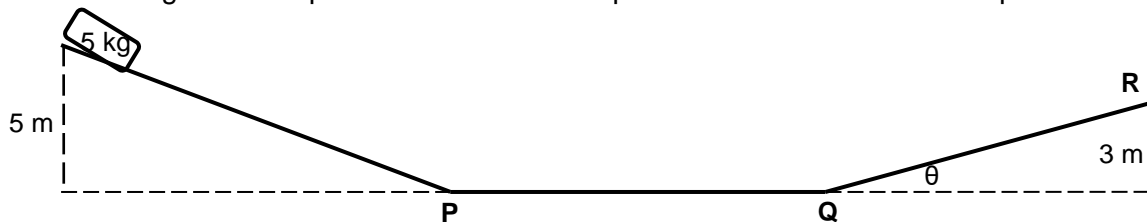

The frictional force, a non-conservative force, between the surface and the block is 18 N.

- 2.1 Using ENERGY PRINCIPLES only, calculate the speed of the block at point **P**. (4)
- 2.2 Explain why the kinetic energy at point **P** is the same as that at point **Q**. (2)
- 2.3 Explain the term *non-conservative force*. (2)
- 2.4 Calculate the angle (θ) of the slope **QR**. (7)

[15]

QUESTION 3

The diagram below shows a heavy block of mass 100 kg sliding **down** a rough 25° inclined plane. A constant force **F** is applied on the block parallel to the inclined plane as shown in the diagram below, so that the block slides down at a **constant velocity**. The magnitude of the kinetic frictional force (f_k) between the block and the surface of the inclined plane is 266 N.

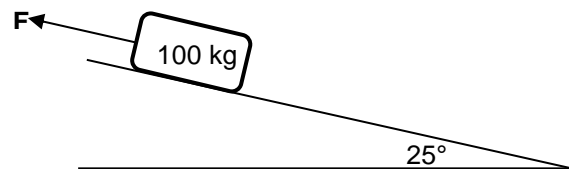

- 3.1 Friction is a non-conservative force. What is meant by the term *non-conservative force*? (2)
- 3.2 A learner states that the net work done on the block is greater than zero.
- 3.2.1 Is the learner correct? Answer only YES or NO. (1)
- 3.2.2 Explain the answer to QUESTION 3.2.1 using physics principles. (2)
- 3.3 Calculate the magnitude of the force **F**. (4)

If the block is released from rest without the force **F** being applied, it moves 3 m down the inclined plane.

- 3.4 Calculate the speed of the block at the bottom of the inclined plane. (6)

[15]

QUESTION 4

The track for a motorbike race consists of a straight, horizontal section that is 800 m long.

A participant, such as the one in the picture, rides at a certain average speed and completes the 800 m course in 75 s. To maintain this speed, a constant driving force of 240 N acts on the motorbike.



4.1 Calculate the average power developed by the motorbike for this motion. (3)

Another person practises on the same motorbike on a track with an incline. Starting from rest, the person rides a distance of 450 m up the incline which has a vertical height of 5 m, as shown.

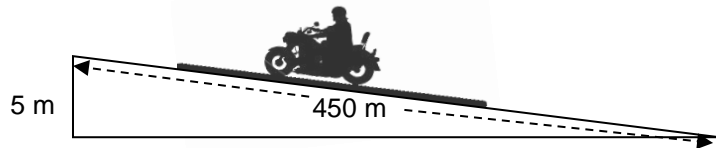

The total frictional force acting on the motorbike is 294 N. The combined mass of rider and motorbike is 300 kg. The average driving force on the motorbike as it moves up the incline is 350 N. Consider the motorbike and rider as a single system.

4.2 Draw a labelled free-body diagram for the motorbike-rider system on the incline. (4)

4.3 State the WORK-ENERGY theorem in words. (2)

4.4 Use energy principles to calculate the speed of the motorbike at the end of the 450 m ride. (6)

[15]

QUESTION 5

A constant force **F**, applied at an angle of 20° above the horizontal, pulls a 200 kg block, over a distance of 3 m, on a rough, horizontal floor as shown in the diagram below.

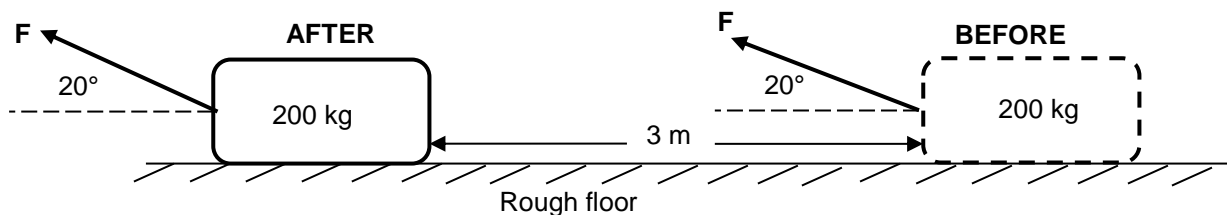

The coefficient of kinetic friction, μ_k , between the floor surface and the block is 0,2.

5.1 Give a reason why the coefficient of kinetic friction has no units. (1)

5.2 State the work-energy theorem in words. (2)

5.3 Draw a free-body diagram indicating ALL the forces acting on the block while it is being pulled. (4)

5.4 Show that the work done by the kinetic frictional force (W_{fk}) on the block can be written as $W_{fk} = (-1\ 176 + 0,205\ F)\text{ J}$. (4)

5.5 Calculate the magnitude of the force **F** that has to be applied so that the net work done by all forces on the block is zero. (4)

[15]

QUESTION 6

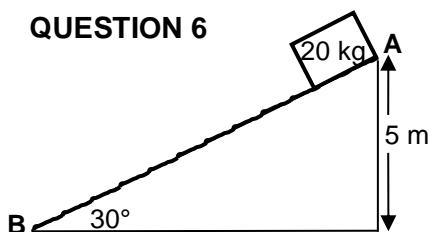

A 20 kg block is released from rest from the top of a ramp at point **A** at a construction site as shown in the diagram. The ramp is inclined at an angle of 30° to the horizontal and its top is at a height of 5 m above the ground.

6.1 State the *principle of conservation of mechanical energy* in words. (2)

6.2 The kinetic frictional force between the 20 kg block and the surface of the ramp is 30 N. Use *energy principles* to calculate the:

6.2.1 Work done by the kinetic frictional force on the block (3)

6.2.2 Speed of the block at point **B** at the bottom of the ramp (5)

6.3 A 100 kg object is pulled up the SAME RAMP at a constant speed of $2 \text{ m}\cdot\text{s}^{-1}$ by a small motor. The kinetic frictional force between the 100 kg object and the surface of the ramp is 25 N. Calculate the average power delivered by the small motor in the pulling of the object up the incline. (4)

[14]

QUESTION 7

A pendulum with a bob of mass 5 kg is held stationary at a height h metres above the ground. When released, it collides with a block of mass 2 kg which is stationary at point **A**. The bob swings past **A** and comes to rest momentarily at a position $\frac{1}{4}h$ above the ground. The diagrams below are NOT drawn to scale.

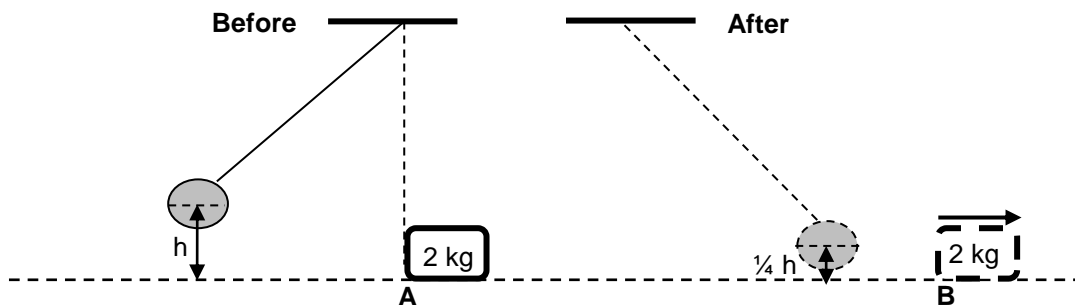

Immediately after the collision the 2 kg block begins to move from **A** to **B** at a constant speed of $4,95 \text{ m}\cdot\text{s}^{-1}$. Ignore frictional effects and assume that no loss of mechanical energy occurs during the collision.

7.1 Calculate the kinetic energy of the block immediately after the collision. (3)

7.2 Calculate the height h (4)

The block moves from point **B** at a velocity of $4,95 \text{ m}\cdot\text{s}^{-1}$ up a rough inclined plane to point **C**. The speed of the block at point **C** is $2 \text{ m}\cdot\text{s}^{-1}$. Point **C** is 0,5 m above the horizontal, as shown in the diagram below. During its motion from **B** to **C** a uniform frictional force acts on the block.

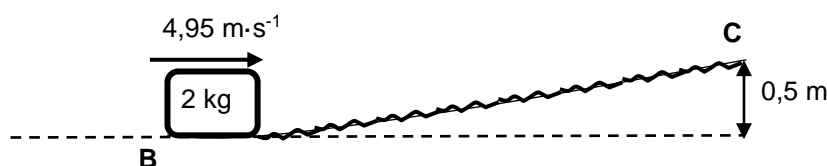

7.3 State the work-energy theorem in words. (2)

7.4 Use energy principles to calculate the work done by the frictional force when the 2 kg block moves from point **B** to point **C**. (4)

[13]

QUESTION 8

The diagram below shows a bullet of mass 20 g that is travelling horizontally. The bullet strikes a stationary 7 kg block and becomes embedded in it. The bullet and block together travel on a rough horizontal surface a distance of 2 m before coming to a stop.

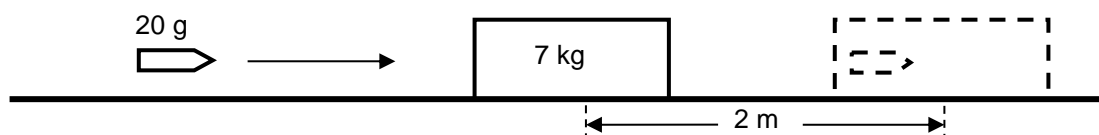

8.1 Use the work-energy theorem to calculate the magnitude of the velocity of the bullet-block system immediately after the bullet strikes the block, given that the frictional force between the block and surface is 10 N. (5)

- 8.2 State the *principle of conservation of linear momentum* in words. (2)
- 8.3 Calculate the magnitude of the velocity with which the bullet hits the block. (4)
- [11]

QUESTION 9

The diagram below shows a boy skateboarding on a ramp which is inclined at 20° to the horizontal. A constant frictional force of 50 N acts on the skateboard as it moves from **P** to **Q**. Consider the boy and the skateboard as a single unit of mass 60 kg. Ignore the effects of air friction.

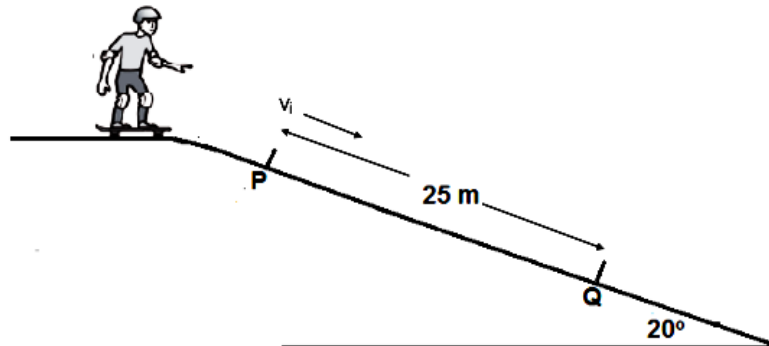

- 9.1 Draw a labelled free-body diagram, showing ALL the forces acting on the boy-skateboard unit while moving down the ramp from **P** to **Q**. (3)

Points **P** and **Q** on the ramp are 25 m apart. The skateboarder passes point **P** at a speed v_i and passes point **Q** at a speed of $15 \text{ m}\cdot\text{s}^{-1}$. Ignore rotational effects due to the wheels of the skateboard.

- 9.2 State the work-energy theorem in words. (2)
- 9.3 Use energy principles to calculate the speed v_i of the skateboarder at point **P**. (5)
- 9.3 Calculate the average power dissipated by the skateboarder to overcome friction between **P** and **Q**. (4)
- [14]

QUESTION 10

A lift arrangement comprises an electric motor, a cage and its counterweight. The counterweight moves vertically downwards as the cage moves upwards. The cage and counterweight move at the same constant speed. Refer to the diagram below.

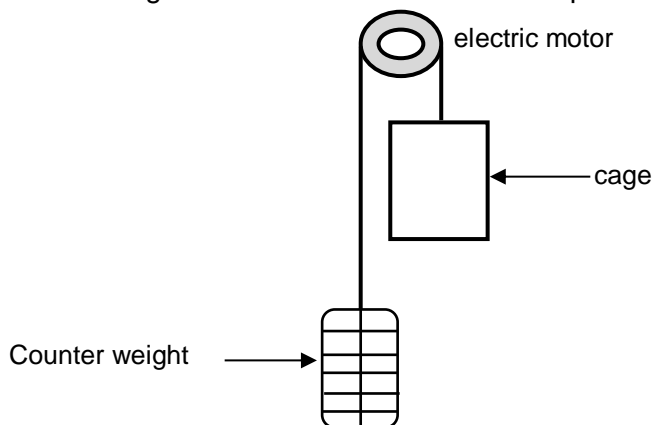

The cage, carrying passengers, moves vertically upwards at a constant speed, covering 55 m in 3 minutes. The counterweight has a mass of 950 kg. The total mass of the cage and passengers is 1 200 kg.

The electric motor provides the power needed to operate the lift system. Ignore the effects of friction.

- 10.1 Define the term *power* in words. (2)
- 10.2 Calculate the work done by the:
- 10.2.1 Gravitational force on the cage (3)
- 10.2.2 Counterweight on the cage (2)

- 10.3 Calculate the average power required by the motor to operate the lift arrangement in 3 minutes. Assume that there are no energy losses due to heat and sound.

(6)
[13]

QUESTION 11

In the diagram below, a 4 kg block lying on a rough horizontal surface is connected to a 6 kg block by a light inextensible string passing over a light frictionless pulley. Initially the blocks are HELD AT REST.

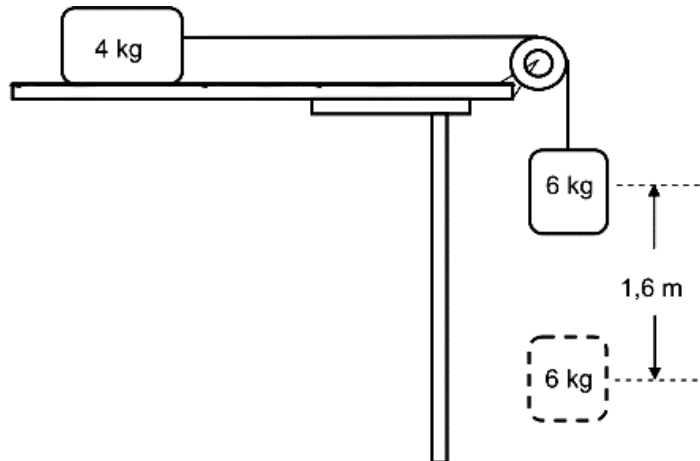

- 11.1 State the work-energy theorem in words.

(2)

When the blocks are released, the 6 kg block falls through a vertical distance of 1,6 m.

- 11.2 Draw a labelled free-body diagram for the 6 kg block.

(2)

- 11.3 Calculate the work done by the gravitational force on the 6 kg block.

(3)

The coefficient of kinetic friction between the 4 kg block and the horizontal surface is 0,4. Ignore the effects of air resistance.

- 11.4 Use energy principles to calculate the speed of the 6 kg block when it falls through 1,6 m while still attached to the 4 kg block.

(5)
[12]

QUESTION 12

A slide, **PQR**, at an amusement park consists of a curved *frictionless* section, **PQ**, and a section, **QR**, which is rough, straight and inclined at 30° to the horizontal. The starting point, **P**, is 3 m above point **Q**. The straight section, **QR**, is 5 m long.

A learner, with mass 50 kg, starting from rest at **P**, slides down section **PQ**, then continues down the straight section, **QR**.

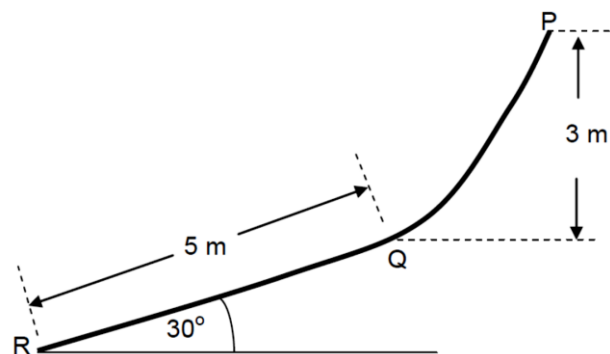

- 12.1 State the law of conservation of mechanical energy in words.

(2)

- 12.2 Calculate the speed of the learner at **Q**.

(4)

- 12.3 Draw a labelled free-body diagram for the learner while he/she is on section **QR**.

(3)

The coefficient of kinetic friction (μ_k) between the learner and the surface **QR** is 0,08.

- 12.4 Calculate the magnitude of the kinetic frictional force acting on the learner when the learner is on section **QR**.

(3)

- 12.5 Use energy principles to calculate the speed of the learner at point **R**.

(5)
[17]

QUESTION 13

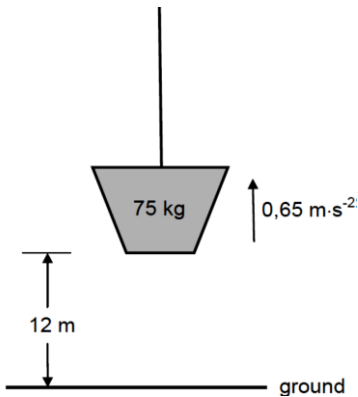

A load of mass 75 kg is initially at rest on the ground. It is then pulled vertically upwards at a constant acceleration of $0,65 \text{ m}\cdot\text{s}^{-2}$ by means of a light inextensible rope. Refer to the diagram below. Ignore air resistance, rotational effects and the mass of the rope.

- 13.1 Draw a labelled free-body diagram for the load while it moves upward. (2)
 - 13.2 Name the non-conservative force acting on the load. (1)
 - 13.3 Calculate the work done on the load by the gravitational force when the load has reached a height of 12 m. (3)
 - 13.4 State the work-energy theorem in words. (2)
 - 13.5 Use the work-energy theorem to calculate the speed of the load when it is at a height of 12 m. (5)
- [13]**

QUESTION 14

The diagram, not drawn to scale, shows a vehicle with a mass of 1 500 kg starting from rest at point A at the bottom of a rough incline. Point B is 200 m vertically above the horizontal. The total work done by force F that moves the vehicle from point A to point B in 90 s is $4,80 \times 10^6 \text{ J}$.

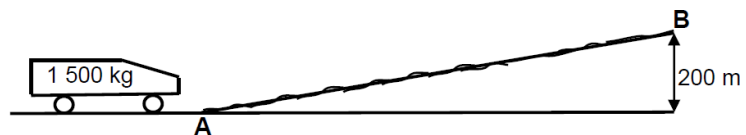

- 14.1 Define the term *non-conservative force*. (2)
 - 14.2 Is force F a conservative force? Choose from: YES or NO. (1)
 - 14.3 Calculate the average power generated by force F. (3)
- The speed of the vehicle when it reaches point B is $25 \text{ m}\cdot\text{s}^{-1}$.
- 14.4 State the work-energy theorem in words. (2)
 - 14.5 Use **energy principles** to calculate the total work done on the vehicle by the frictional forces. (5)
- [13]**

DOPPLER EFFECT

QUESTION 1

- 1.1 The siren of a stationary ambulance emits a note of frequency 1 130 Hz. When the ambulance moves at a constant speed, a stationary observer detects a frequency that is 70 Hz **higher** than that emitted by the siren.
 - 1.1.1 State the Doppler effect in words. (2)
 - 1.1.2 Is the ambulance moving *towards* or *away from* the observer? Give a reason. (2)
 - 1.1.3 Calculate the speed at which the ambulance is travelling. Take the speed of sound in air as $343 \text{ m}\cdot\text{s}^{-1}$. (5)
- 1.2 A study of spectral lines obtained from various stars can provide valuable information about the movement of the stars. The two diagrams below represent different spectral lines of an element. Diagram 1 represents the spectrum of the element in a laboratory on Earth. Diagram 2 represents the spectrum of the same element from a distant star.

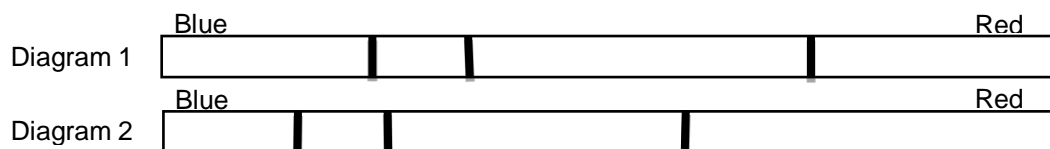

Is the star moving *towards* or *away from* the Earth? Explain the answer by referring to the shifts in the spectral lines in the two diagrams above. (2)

[11]

QUESTION 2

The Doppler effect is applicable to both sound and light waves. It also has very important applications in our everyday lives.

- 2.1 A hooter on a stationary train emits sound with a frequency of 520 Hz, as detected by a person standing on the platform. Assume that the speed of sound is $340 \text{ m}\cdot\text{s}^{-1}$ in still air. Calculate the:
- 2.1.1 Wavelength of the sound detected by the person (2)
- 2.1.2 Wavelength of the sound detected by the person when the train moves towards him/her at a constant speed of $15 \text{ m}\cdot\text{s}^{-1}$ with the hooter still emitting sound (6)
- 2.2 Explain why the wavelength calculated in QUESTION 2.1.1 differs from that obtained in QUESTION 2.1.2. (2)
- 2.3 Use your knowledge of the Doppler effect to explain *red shifts*. (2)
- [12]**

QUESTION 3

The graph below shows the relationship between the apparent frequency (f_L) of the sound heard by a STATIONARY listener and the velocity (v_s) of the source travelling TOWARDS the listener.

Graph showing apparent frequency (f_L) versus velocity of sound source (v_s)

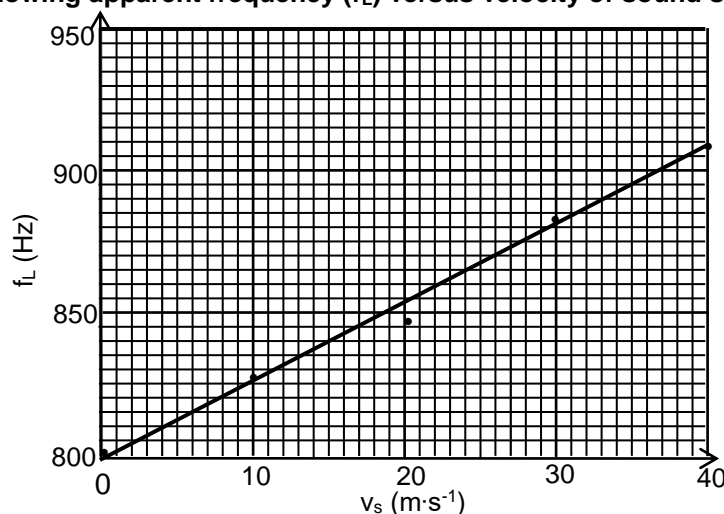

- 3.1 State the Doppler effect in words. (2)
- 3.2 Use the information in the graph to calculate the speed of sound in air. (5)
- 3.3 Sketch a graph of apparent frequency (f_L) versus velocity (v_s) of the sound source if the source was moving AWAY from the listener. It is not necessary to use numerical values for the graph. (2)
- [9]**

QUESTION 4

- 4.1 The data below was obtained during an investigation into the relationship between the different velocities of a moving sound source and the frequencies detected by a stationary listener for **each** velocity. The effect of wind was ignored in this investigation.

Experiment number	1	2	3	4
Velocity of the sound source ($\text{m}\cdot\text{s}^{-1}$)	0	10	20	30
Frequency (Hz) of the sound detected by the stationary listener	900	874	850	827

- 4.1.1 Write down the dependent variable for this investigation. (1)
- 4.1.2 State the Doppler effect in words. (2)

- 4.1.3 Was the sound source moving TOWARDS or AWAY FROM the listener? Give a reason for the answer. (2)
- 4.1.4 Use the information in the table to calculate the speed of sound during the investigation. (5)
- 4.2 The spectral lines of a distant star are shifted towards the longer wavelengths of light. Is the star moving TOWARDS or AWAY FROM the Earth? (1)

[11]**QUESTION 5**

Reflection of sound waves enables bats to hunt for moths. The sound wave produced by a bat has a frequency of 222 kHz and a wavelength of $1,5 \times 10^{-3}$ m.

- 5.1 Calculate the speed of this sound wave through the air. (3)
- 5.2 A stationary bat sends out a sound signal and receives the same signal reflected from a moving moth at a frequency of 230,3 kHz.
- 5.2.1 Is the moth moving TOWARDS or AWAY FROM the bat? (1)
- 5.2.2 Calculate the magnitude of the velocity of the moth, assuming that the velocity is constant. (6)

[10]**QUESTION 6**

An ambulance is travelling towards a hospital at a constant velocity of $30 \text{ m}\cdot\text{s}^{-1}$. The siren of the ambulance produces sound of frequency 400 Hz. Take the speed of sound in air as $340 \text{ m}\cdot\text{s}^{-1}$. The diagram shows the wave fronts of the sound produced from the siren as a result of this motion.

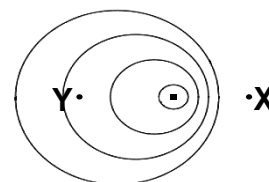

- 6.1 At which side of the diagram, X or Y, is the hospital situated? (1)
- 6.2 Explain the answer to QUESTION 6.1. (3)
- 6.3 Calculate the frequency of the sound of the siren heard by a person standing at the hospital. (5)
- 6.4 A nurse is sitting next to the driver in the passenger seat of the ambulance as it approaches the hospital. Calculate the wavelength of the sound heard by the nurse. (3)

[12]**QUESTION 7**

- 7.1 An ambulance is moving towards a stationary listener at a constant speed of $30 \text{ m}\cdot\text{s}^{-1}$. The siren of the ambulance emits sound waves having a wavelength of 0,28 m. Take the speed of sound in air as $340 \text{ m}\cdot\text{s}^{-1}$.
- 7.1.1 State the Doppler effect in words. (2)
- 7.1.2 Calculate the frequency of the sound waves emitted by the siren as heard by the ambulance driver. (3)
- 7.1.3 Calculate the frequency of the sound waves emitted by the siren as heard by the listener. (5)
- 7.1.4 How would the answer to QUESTION 7.1.3 change if the speed of the ambulance were LESS THAN $30 \text{ m}\cdot\text{s}^{-1}$? Write down only INCREASES, DECREASES or REMAINS THE SAME. (1)
- 7.2 An observation of the spectrum of a distant star shows that it is moving away from the earth. Explain, in terms of the frequencies of the spectral lines, how it is possible to conclude that the star is moving away from the earth. (2)

[13]

QUESTION 8

The speed of sound in air depends among others on the air temperature. The following graph shows this relationship.

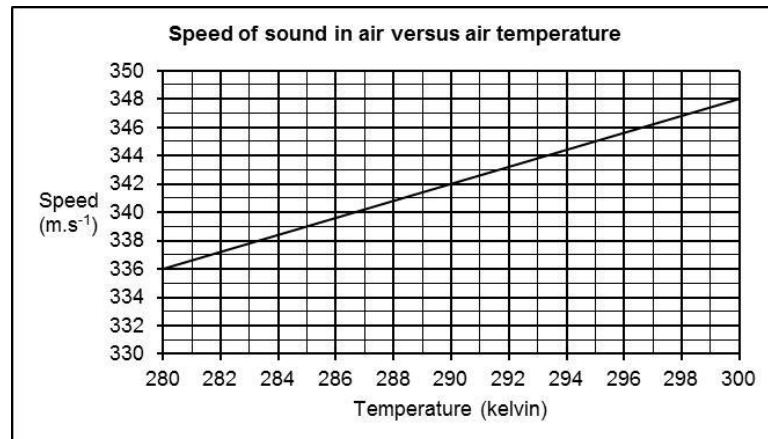

- 8.1 Which one of temperature or speed is the dependent variable? (1)
- 8.2 The gradient of this graph is equal to $0,6 \text{ m}\cdot\text{s}^{-1}\cdot\text{K}^{-1}$. With how much does the speed, in $\text{m}\cdot\text{s}^{-1}$, increase for every 5 K increase in temperature? (1)
- 8.3 Two experiments are done to verify the Doppler effect. In the first experiment, an object approaches a stationary observer **X** at a constant speed of $57,5 \text{ m}\cdot\text{s}^{-1}$. The object is equipped with a siren that emits sound waves at a fixed frequency of 1 000 Hz. The motion takes place in still air at a temperature of 295 K.
- 8.3.1 Describe what the *Doppler effect* is. (2)
- 8.3.2 What is the speed of sound, in $\text{m}\cdot\text{s}^{-1}$, in air at 295 K? (Use the graph.) (1)
- 8.3.3 Calculate the frequency measured by observer **X**. (4)
- 8.3.4 In the second experiment, the object moves away from observer **X** at the same constant speed as before. What should the air temperature, in kelvin, be to make it a fair test between the two experiments? (1)
- 8.4 Consider the three diagrams below. Each one represents the source (with the siren) and observer **X**. Two of the diagrams are applicable on the above-mentioned experiments.

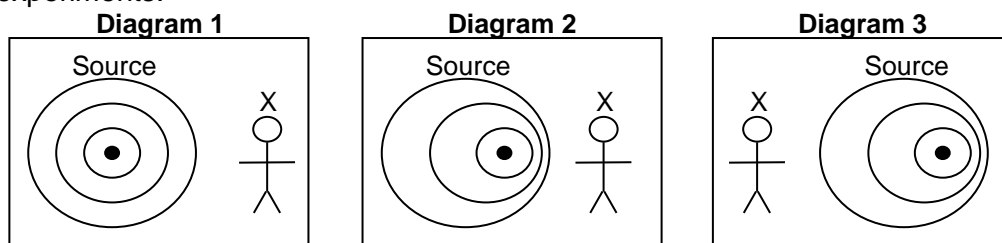

- 8.4.1 Which diagram is applicable to experiment 2? (1)
- 8.4.2 Which diagram is NOT applicable to any of the experiments? Give a reason for your answer. (2)

[13]**QUESTION 9**

- 9.1 A police car is moving at constant velocity on a freeway. The siren of the car emits sound waves with a frequency of 330 Hz. A stationary sound detector measures the frequency of the sound waves of the approaching siren as 365 Hz.
- 9.1.1 State the Doppler Effect in words. (2)
- 9.1.2 Calculate the speed of the car. (Speed of sound in air is $340 \text{ m}\cdot\text{s}^{-1}$.) (5)
- 9.2 The spectrum of a distant star when viewed from an observatory on Earth appears to have undergone a red shift. Explain the term red shift. (3)

[10]

QUESTION 10

- 10.1 A sound source is moving at constant velocity past a stationary observer. The frequency detected as the source approaches the observer is 2 600 Hz. The frequency detected as the source moves away from the observer is 1 750 Hz. Take the speed of sound in air as $340 \text{ m}\cdot\text{s}^{-1}$.
- 10.1.1 Name the phenomenon that describes the apparent change in frequency detected by the observer. (1)
- 10.1.2 State ONE practical application of the phenomenon in QUESTION 10.1.1 in the field of medicine. (1)
- 10.1.3 Calculate the speed of the moving source. (6)
- 10.1.4 Will the observed frequency INCREASE, DECREASE or REMAIN THE SAME if the velocity of the source increased as it:
- (a) Moves towards the observer (1)
- (b) Moves away from the observer (1)
- 10.2 Spectral lines of star **X** at an observatory are observed to be *red shifted*.
- 10.2.1 Explain the term *red shifted* in terms of wavelength. (2)
- 10.2.2 Will the frequency of the light observed from the star INCREASE, DECREASE or REMAIN THE SAME? (1)

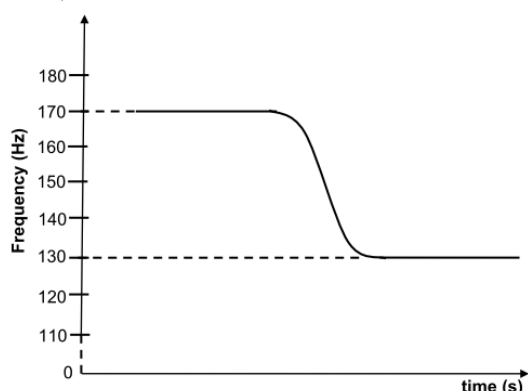
[13]**QUESTION 11**

A police car moving at a constant velocity with its siren on, passes a stationary listener. The graph shows the changes in the frequency of the sound of the siren detected by the listener.

- 11.1 State the Doppler Effect in words. (2)
- 11.2 Write down the frequency of the sound detected by the listener as the police car:
- 11.2.1 Approaches the listener (1)
- 11.2.2 Moves away from the listener (1)
- 11.3 Calculate the speed of the police car. Take the speed of sound in air to be $340 \text{ m}\cdot\text{s}^{-1}$. (6)

[10]**QUESTION 12**

A police car is moving at a constant speed on a straight horizontal road. The siren of the car emits sound of constant frequency. EACH of two observers, **A** and **B**, standing some distance apart on the same side of the road, records the frequency of the detected sound. Observer **A** records a frequency of 690 Hz and observer **B** records a frequency of 610 Hz.

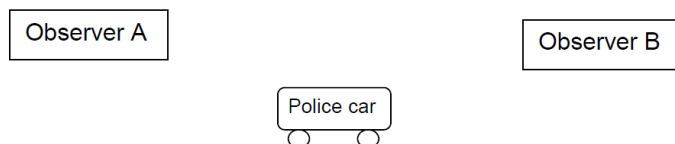

- 12.1 State the Doppler effect in words. (2)
- 12.2 In which direction is the car moving? Choose from TOWARDS A or AWAY FROM A. Give a reason for the answer. (2)
- 12.3 Determine the speed of the police car. Take the speed of sound in air as $340 \text{ m}\cdot\text{s}^{-1}$. (6)
- 12.4 Name ONE application of the Doppler effect. (1)

[11]

QUESTION 13

A sound source, moving at a constant speed of $240 \text{ m}\cdot\text{s}^{-1}$ towards a detector, emits sound at a constant frequency. The detector records a frequency of $5\,100 \text{ Hz}$. Take the speed of sound in air to be $340 \text{ m}\cdot\text{s}^{-1}$.

- 13.1 State the Doppler effect in words. (2)
- 13.2 Calculate the wavelength of the sound emitted by the source. (7)
- Some of the sound waves are reflected from the detector towards the approaching source.
- 13.3 Will the frequency of the reflected sound wave detected by the sound source be EQUAL TO, GREATER THAN or SMALLER THAN $5\,100 \text{ Hz}$? (1)
- [10]**

QUESTION 14

The alarm of a vehicle parked next to a straight horizontal road goes off, emitting sound with a wavelength of $0,34 \text{ m}$. A patrol car is moving at a constant speed on the same road. The driver of the patrol car hears a sound with a frequency of 50 Hz **lower than** the sound emitted by the alarm. Take the speed of sound in air as $340 \text{ m}\cdot\text{s}^{-1}$.

- 14.1 State the Doppler effect in words. (2)
- 14.2 Is the patrol car driving TOWARDS or AWAY FROM the parked vehicle? Give a reason for the answer. (2)
- 14.3 Calculate the frequency of the sound emitted by the alarm. (3)
- 14.4 The patrol car moves a distance of x metres in 10 seconds. Calculate the distance x . (6)
- [13]**

ELECTROSTATICS**QUESTION 1**

The diagram shows two small identical metal spheres, **R** and **S**, each placed on a wooden stand. Spheres **R** and **S** carry charges of $+8 \mu\text{C}$ and $-4 \mu\text{C}$ respectively. Ignore the effects of air.

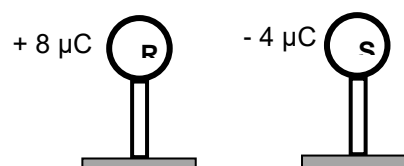

- 1.1 Explain why the spheres were placed on wooden stands. (1)
- Spheres **R** and **S** are brought into contact for a while and then separated by a small distance.
- 1.2 Calculate the net charge on each of the spheres. (2)
- 1.3 Draw the electric field pattern due to the two spheres **R** and **S**. (3)

After **R** and **S** have been in contact and separated, a third sphere, **T**, of charge $+1 \mu\text{C}$ is now placed between them as shown in the diagram below.

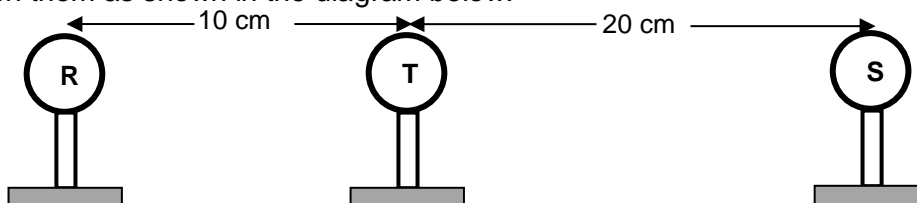

- 1.4 Draw a free-body diagram showing the electrostatic forces experienced by sphere **T** due to spheres **R** and **S**. (2)
- 1.5 Calculate the net electrostatic force experienced by **T** due to **R** and **S**. (6)
- 1.6 Define the *electric field at a point*. (2)
- 1.7 Calculate the magnitude of the net electric field at the location of **T** due to **R** and **S**. (3)
- [19]**

QUESTION 2

Two identical negatively charged spheres, **A** and **B**, having charges of the **same magnitude**, are placed 0,5 m apart in vacuum. The magnitude of the electrostatic force that one sphere exerts on the other is $1,44 \times 10^{-1}$ N.

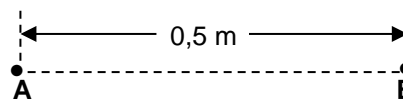

- 2.1 State Coulomb's law in words. (2)
- 2.2 Calculate the:
 - 2.2.1 Magnitude of the charge on each sphere (4)
 - 2.2.2 Excess number of electrons on sphere **B** (3)
- 2.3 **P** is a point at a distance of 1 m from sphere **B**.

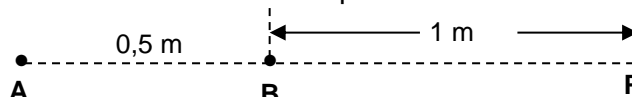

- 2.3.1 What is the direction of the net electric field at point **P**? (1)
 - 2.3.2 Calculate the number of electrons that should be removed from sphere **B** so that the net electric field at point **P** is $3 \times 10^4 \text{ N}\cdot\text{C}^{-1}$ to the right. (8)
- [18]**

QUESTION 3

Three point charges, **Q₁**, **Q₂** and **Q₃**, carrying charges of $+6 \mu\text{C}$, $-3 \mu\text{C}$ and $+5 \mu\text{C}$ respectively, are arranged in space as shown in the diagram below. The distance between **Q₃** and **Q₁** is 30 cm and that between **Q₃** and **Q₂** is 10 cm.

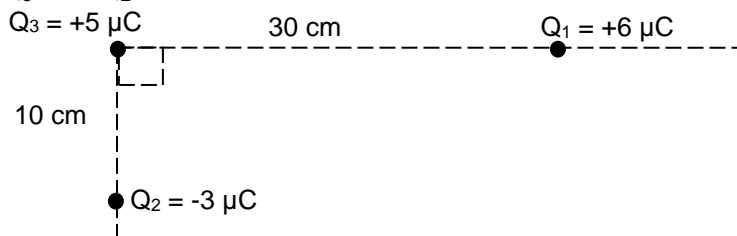

- 3.1 State Coulomb's law in words. (2)
 - 3.2 Calculate the net force acting on charge **Q₃** due to the presence of **Q₁** and **Q₂**. (7)
- [9]**

QUESTION 4

Two identical neutral spheres, **M** and **N**, are placed on insulating stands. They are brought into contact and a charged rod is brought near sphere **M**.

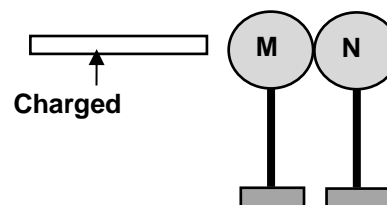

When the spheres are separated it is found that 5×10^6 electrons were transferred from sphere **M** to sphere **N**.

- 4.1 What is the net charge on sphere **N** after separation? (3)
- 4.2 Write down the net charge on sphere **M** after separation. (2)

The charged spheres, **M** and **N**, are now arranged along a straight line, in space, such that the distance between their centres is 15 cm. A point **P** lies 10 cm to the *right* of **N** as shown in the diagram below.

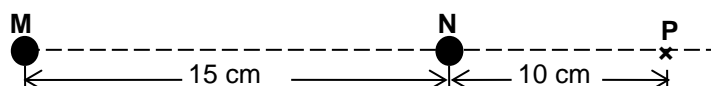

- 4.3 Define the *electric field* at a point. (2)
 - 4.4 Calculate the net electric field at point **P** due to **M** and **N**. (6)
- [13]**

QUESTION 5

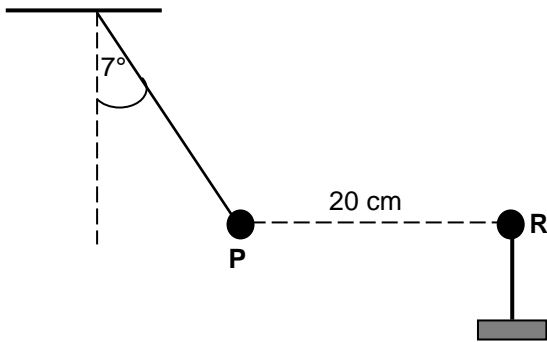

A very small graphite-coated sphere **P** is rubbed with a cloth. It is found that the sphere acquires a charge of $+ 0,5 \mu\text{C}$.

5.1 Calculate the number of electrons removed from sphere **P** during the charging process. (3)

Now the charged sphere **P** is suspended from a light, inextensible string. Another sphere, **R**, with a charge of $- 0,9 \mu\text{C}$, on an insulated stand, is brought close to sphere **P**.

As a result sphere **P** moves to a position where it is 20 cm from sphere **R**, as shown. The system is in equilibrium and the angle between the string and the vertical is 7° .

5.2 Draw a labelled free-body diagram showing ALL the forces acting on sphere **P**. (3)

5.3 State Coulomb's law in words. (2)

5.4 Calculate the magnitude of the tension in the string. (5)

[13]

QUESTION 6

Two charged particles, **Q₁** and **Q₂**, are placed 0,4 m apart along a straight line. The charge on **Q₁** is $+ 2 \times 10^{-5} \text{ C}$, and the charge on **Q₂** is $- 8 \times 10^{-6} \text{ C}$. Point **X** is 0,25 m east of **Q₁**, as shown in the diagram below.

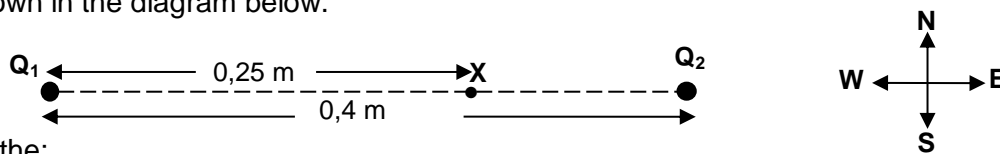

Calculate the:

6.1 Net electric field at point **X** due to the two charges (6)

6.2 Electrostatic force that a $- 2 \times 10^{-9} \text{ C}$ charge will experience at point **X** (4)

The $- 2 \times 10^{-9} \text{ C}$ charge is replaced with a charge of $- 4 \times 10^{-9} \text{ C}$ at point **X**.

6.3 Without any further calculation, determine the magnitude of the force (1)

that the $- 4 \times 10^{-9} \text{ C}$ charge will experience at point **X**. [11]

QUESTION 7

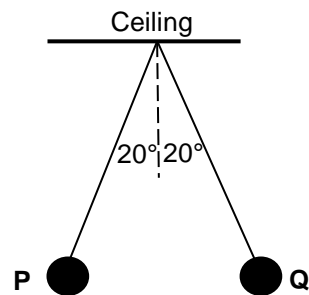

Two identical spherical balls, **P** and **Q**, each of mass 100 g, are suspended at the same point from a ceiling by means of identical light, inextensible insulating strings. Each ball carries a charge of $+250 \text{ nC}$. The balls come to rest in the positions shown in the diagram.

7.1 In the diagram, the angles between each string and the vertical are the same. Give a reason why the angles are the same. (1)

7.2 State Coulomb's law in words. (2)

7.3 The free-body diagram, not drawn to scale, of the forces acting on ball **P** is shown alongside. Calculate the:

7.3.1 Magnitude of the tension (**T**) in the string (3)

7.3.2 Distance between balls **P** and **Q** (5)

[11]

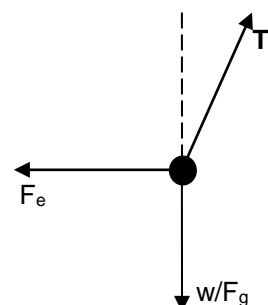

QUESTION 8

A sphere Q_1 , with a charge of $-2,5 \mu\text{C}$, is placed 1 m away from a second sphere Q_2 , with a charge $+6 \mu\text{C}$. The spheres lie along a straight line, as shown in the diagram below. Point P is located a distance of 0,3 m to the left of sphere Q_1 , while point X is located between Q_1 and Q_2 . The diagram is not drawn to scale.

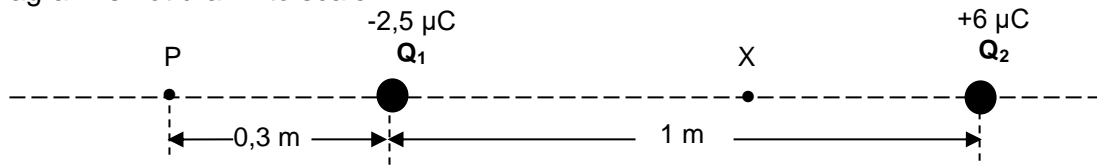

8.1 Show, with the aid of a VECTOR DIAGRAM, why the net electric field at point X cannot be zero. (4)

8.2 Calculate the net electric field at point P , due to the two charged spheres Q_1 and Q_2 . (6)

[10]

QUESTION 9

A small sphere, Q_1 , with a charge of $+ 32 \times 10^{-9} \text{ C}$, is suspended from a light string secured to a support. A second, identical sphere, Q_2 , with a charge of $- 55 \times 10^{-9} \text{ C}$, is placed in a narrow, cylindrical glass tube vertically below Q_1 . Each sphere has a mass of 7 g. Both spheres come to equilibrium when Q_2 is 2,5 cm from Q_1 , as shown in the diagram. Ignore the effects of air friction.

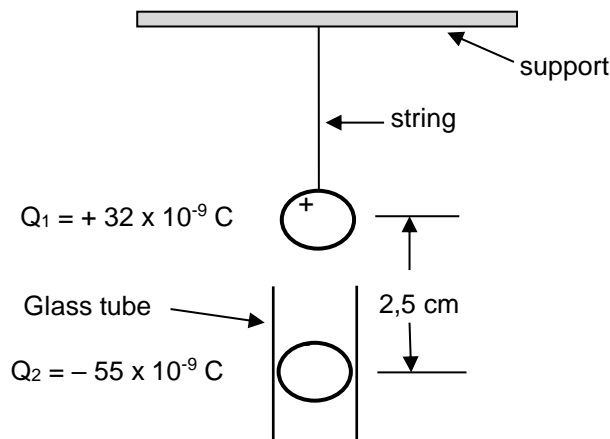

9.1 Calculate the number of electrons that were removed from Q_1 to give it a charge of $+ 32 \times 10^{-9} \text{ C}$. Assume that the sphere was neutral before being charged. (3)

9.2 Draw a labelled free-body diagram showing all the forces acting on sphere Q_1 . (3)

9.3 Calculate the magnitude of the tension in the string. (5)

[11]

QUESTION 10

10.1 Define *electric field at a point* in words. (2)

10.2 Draw the electric field pattern for two identical positively charged spheres placed close to each other. (3)

10.3 A $- 30 \mu\text{C}$ point charge, Q_1 , is placed at a distance of 0,15 m from a $+ 45 \mu\text{C}$ point charge, Q_2 , in space, as shown in the diagram below. The net electric field at point P , which is on the same line as the two charges, is zero.

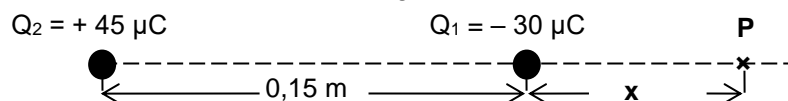

Calculate x , the distance of point P from charge Q_1 .

(5)
[10]

QUESTION 11

- 11.1 In an experiment to verify the relationship between the electrostatic force, F_E , and distance, r , between two **identical**, positively charged spheres, the graph below was obtained.

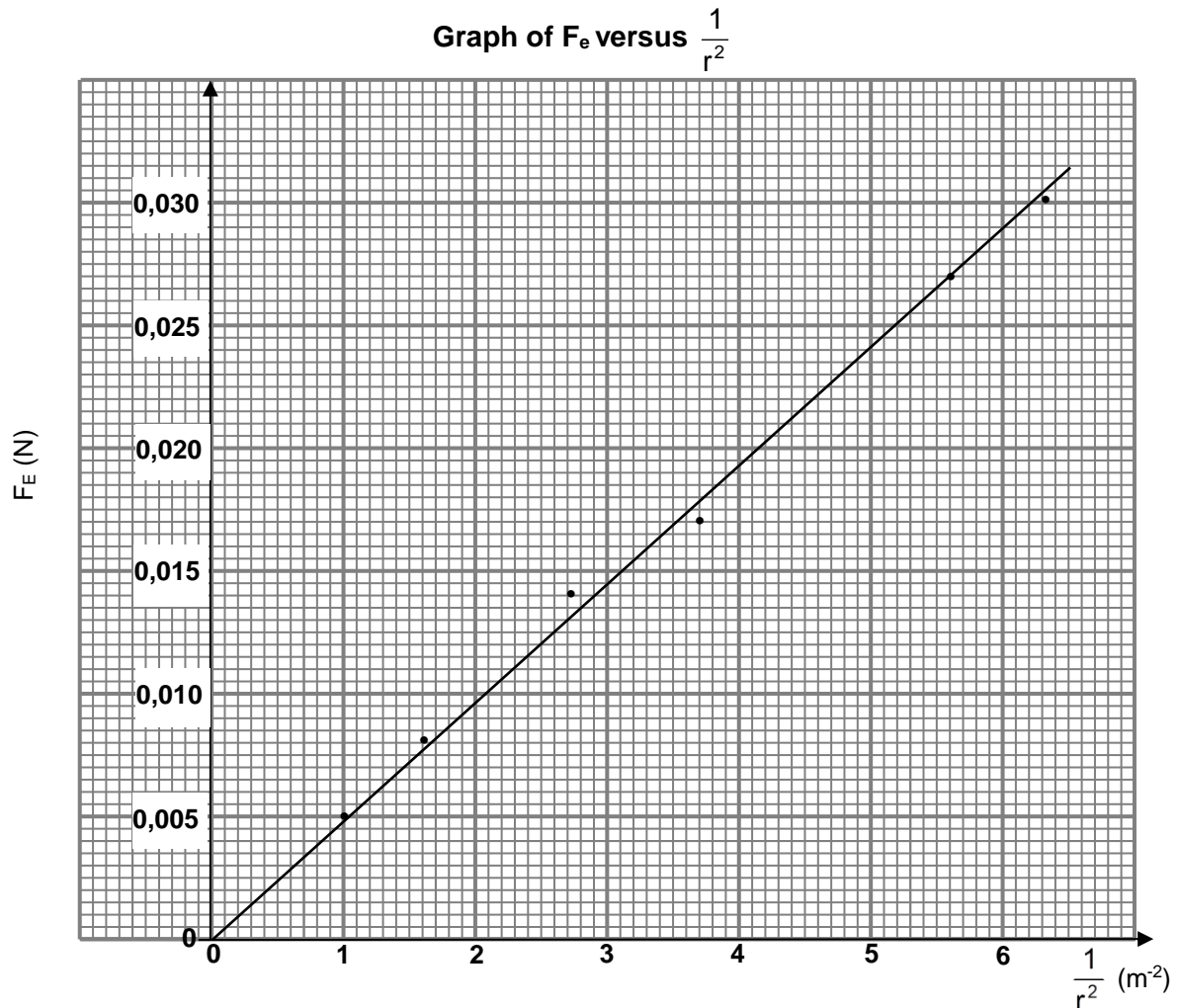

- 11.1.1 State Coulomb's law in words. (2)
- 11.1.2 Write down the dependent variable of the experiment. (1)
- 11.1.3 What relationship between the electrostatic force F_E and the square of the distance, r^2 , between the charged spheres can be deduced from the graph? (1)
- 11.1.4 Use the information in the graph to calculate the charge on each sphere. (6)
- 11.2 A charged sphere, **A**, carries a charge of $-0,75 \mu\text{C}$.
- 11.2.1 Draw a diagram showing the electric field lines surrounding sphere **A**. (2)
- Sphere **A** is placed 12 cm away from another charged sphere, **B**, along a straight line in a vacuum, as shown below. Sphere **B** carries a charge of $+0,8 \mu\text{C}$. Point **P** is located 9 cm to the right of sphere **A**.
-
- 11.2.2 Calculate the magnitude of the net electric field at point **P**. (5)

[17]

QUESTION 12

In the diagram below, Q_1 , Q_2 and Q_3 are three stationary point charges placed along a straight line. The distance between Q_1 and Q_2 is 1,5 m and that between Q_2 and Q_3 is 1 m, as shown in the diagram.

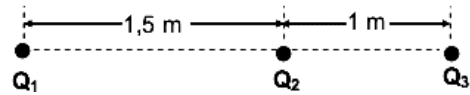

12.1 State Coulomb's law in words. (2)

12.2 The magnitude of charges Q_1 and Q_2 are unknown. The charge on Q_1 is positive. The charge on Q_3 is $+2 \times 10^{-6}$ C and it experiences a net electrostatic force of 0,3 N to the left.

12.2.1 Write down the sign (POSITIVE or NEGATIVE) of charge Q_2 . (2)

Charge Q_2 is now removed. The magnitude of the electrostatic force experienced by charge Q_3 due to Q_1 now becomes 0,012 N.

12.2.2 Calculate the magnitudes of the unknown charges Q_1 and Q_2 . (7) [11]

QUESTION 13

Two small identical spheres, **A** and **B**, each carrying a charge of $+5 \mu\text{C}$, are placed 2 m apart. Point **P** is in the electric field due to the charged spheres and is located 1,25 m from sphere **A**. Study the diagram.

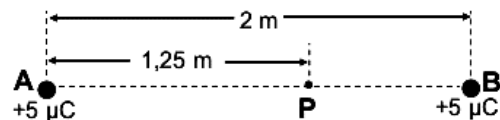

13.1 Describe the term *electric field*. (2)

13.2 Draw the resultant electric field pattern due to the two charged spheres. (3)

13.3 Calculate the magnitude of the net electric field at point **P**. (5) [10]

QUESTION 14

14.1 A metal sphere **A**, suspended from a wooden beam by means of a non-conducting string, has a charge of $+6 \mu\text{C}$.

14.1.1 Were electrons ADDED TO or REMOVED FROM the sphere to obtain this charge? Assume that the sphere was initially neutral. (1)

14.1.2 Calculate the number of electrons added to or removed from the sphere. (3)

14.2 Point charges Q_1 , Q_2 and Q_3 are arranged at the corners of a right-angled triangle, as shown in the diagram. The charges on Q_1 and Q_2 are $+2 \mu\text{C}$ and $-2 \mu\text{C}$ respectively and the magnitude of the charge on Q_3 is $6 \mu\text{C}$.

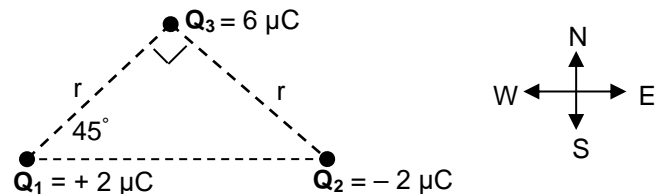

The distance between Q_1 and Q_3 is r . The distance between Q_2 and Q_3 is also r . The charge Q_3 experiences a resultant electrostatic force of 0,12 N to the west.

14.2.1 Without calculation, identify the sign (+ or -) on the charge Q_3 . (1)

14.2.2 Draw a vector diagram to show the electrostatic forces acting on Q_3 due to charges Q_1 and Q_2 respectively. (2)

14.2.3 Write down an expression, in terms of r , for the horizontal component of the electrostatic force exerted on Q_3 by Q_1 . (3)

14.2.4 Calculate the distance r . (4)

14.3 The magnitude of the electric field is $100 \text{ N}\cdot\text{C}^{-1}$ at a point which is 0,6 m away from a point charge Q .

14.3.1 Define the term *electric field at a point* in words. (2)

14.3.2 Calculate the distance from point charge Q at which the magnitude of the electric field is $50 \text{ N}\cdot\text{C}^{-1}$. (5) [21]

QUESTION 15

Two small spheres, **X** and **Y**, carrying charges of $+6 \times 10^{-6} \text{ C}$ and $+8 \times 10^{-6} \text{ C}$ respectively, are placed 0,20 m apart in air.

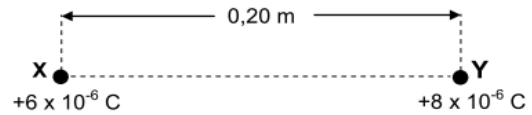

15.1 State Coulomb's law in words. (2)

15.2 Calculate the magnitude of the electrostatic force experienced by charged sphere **X**. (4)

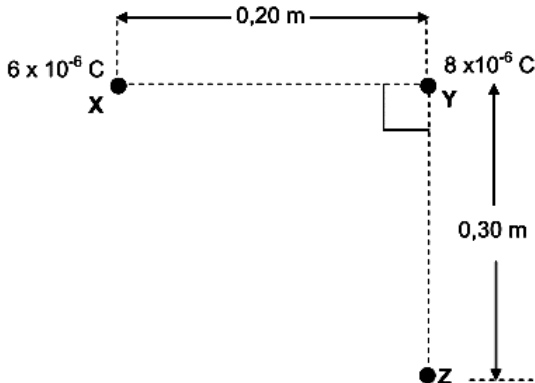

A third sphere, **Z**, of unknown negative charge, is now placed at a distance of 0,30 m below sphere **Y**, in such a way that the line joining the charged spheres **X** and **Y** is perpendicular to the line joining the charged spheres **Y** and **Z**, as shown in the diagram alongside.

15.3 Draw a vector diagram showing the directions of the electrostatic forces and the net force experienced by charged sphere **Y** due to the presence of charged spheres **X** and **Z** respectively. (3)

15.4 The magnitude of the net electrostatic force experienced by charged sphere **Y** is 15,20 N. Calculate the charge on sphere **Z**. (4) [13]

QUESTION 16

A and **B** are two small spheres separated by a distance of 0,70 m. Sphere **A** carries a charge of $+1,5 \times 10^{-6} \text{ C}$ and sphere **B** carries a charge of $-2,0 \times 10^{-6} \text{ C}$. **P** is a point between spheres **A** and **B** and is 0,40 m from sphere **A**, as shown in the diagram.

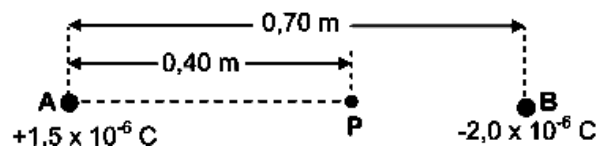

16.1 Define the term electric field at a point. (2)

16.2 Calculate the magnitude of the net electric field at point **P**. (4)

16.3 A point charge of magnitude $3,0 \times 10^{-9} \text{ C}$ is now placed at point **P**. Calculate the magnitude of the electrostatic force experienced by this charge. (3) [9]

QUESTION 17

Two point charges, **P** and **S**, are placed a distance 0,1 m apart. The charge on **P** is $+1,5 \times 10^{-9} \text{ C}$ and that on **S** is $-2 \times 10^{-9} \text{ C}$. A third point charge, **R**, with an unknown positive charge, is placed 0,2 m to the right of point charge **S**, as shown in the diagram below.

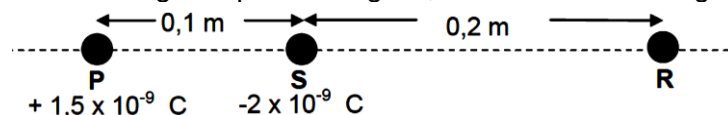

17.1 State Coulomb's law in words. (2)

17.2 Draw a labelled force diagram showing the electrostatic forces acting on **R** due to **P** and **S**. (2)

17.3 Calculate the magnitude of the charge on **R**, if it experiences a net electrostatic force of $1,27 \times 10^{-6} \text{ N}$ to the left. Take forces directed to the right as positive. (7) [11]

QUESTION 18

P is a point 0,5 m from charged sphere **A**. The electric field at **P** is $3 \times 10^7 \text{ N}\cdot\text{C}^{-1}$ directed towards **A**. Refer to the diagram.

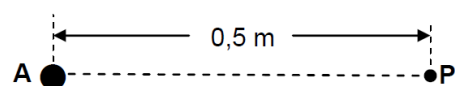

18.1 Draw the electric field pattern due to charged sphere **A**. Indicate the sign of the charge on the sphere in your diagram. (2)

18.2 Calculate the magnitude of the charge on sphere **A**. (3)

- 18.3 Another charged sphere, **B**, having an excess of 10^5 electrons, is now placed at point **P**. Calculate the electrostatic force experienced by sphere **B**. (6)
[11]

QUESTION 19

A particle, **P**, with a charge of $+5 \times 10^{-6}$ C, is located 1,0 m along a straight line from particle **V**, with a charge of $+7 \times 10^{-6}$ C. Refer to the diagram below.

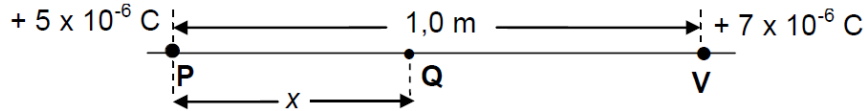

A third charged particle, **Q**, at a point x metres away from **P**, as shown above, experiences a net electrostatic force of zero newton.

- 19.1 How do the electrostatic forces experienced by **Q** due to the charges on **P** and **V** respectively, compare with each other? (2)
19.2 State Coulomb's law in words. (2)
19.3 Calculate the distance x . (5)
[9]

QUESTION 20

A small metal sphere **Y** carries a charge of $+6 \times 10^{-6}$ C.

- 20.1 Draw the electric field pattern associated with sphere **Y**. (2)
20.2 If 8×10^{13} electrons are now transferred to sphere **Y**, calculate the electric field at a point 0,5 m from the sphere. (7)
[9]

QUESTION 21

Three small identical metal spheres, **P**, **S** and **T**, on insulated stands, are **initially neutral**. They are then charged to carry charges of -15×10^{-9} C, **Q** and $+2 \times 10^{-9}$ C respectively, as shown. The charged spheres are brought together so that all three spheres touch each other at the same time, and are then separated.

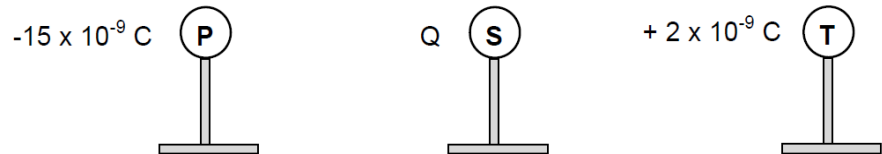

The charge on each sphere, after separation, is -3×10^{-9} C.

- 21.1 Determine the value of charge **Q**. (2)
21.2 Draw the electric field pattern associated with the charged spheres, **S** and **T**, **after they are separated** and returned to their original positions. (3)

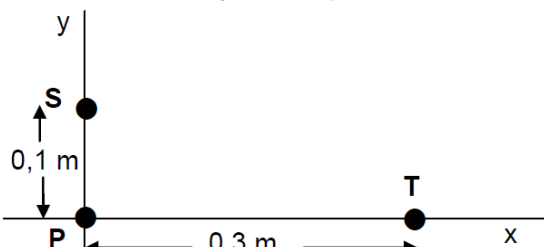

The spheres, each with the **new charge** of -3×10^{-9} C, are now placed at points on the x -axis and the y -axis, as shown in the diagram, with sphere **P** at the origin.

- 21.3 State Coulomb's law in words. (2)
21.4 Calculate the magnitude of the net electrostatic force acting on sphere **P**. (5)
21.5 Calculate the magnitude of the net electric field at the origin due to charges **S** and **T**. (3)
21.6 ONE of the charged spheres, **P** and **T**, experienced a very small increase in mass after it was charged initially.
21.6.1 Which sphere, **P** or **T**, experienced this very small increase in mass? (1)
21.6.2 Calculate the increase in mass by the sphere in QUESTION 21.6.1. (3)
[19]

ELECTRIC CIRCUITS

QUESTION 1

1.1 A group of learners conduct an experiment to determine the emf (ϵ) and internal resistance (r) of a battery. They connect a battery to a rheostat (variable resistor), a low-resistance ammeter and a high-resistance voltmeter as shown in the diagram below. The data obtained from the experiment is displayed in the table below.

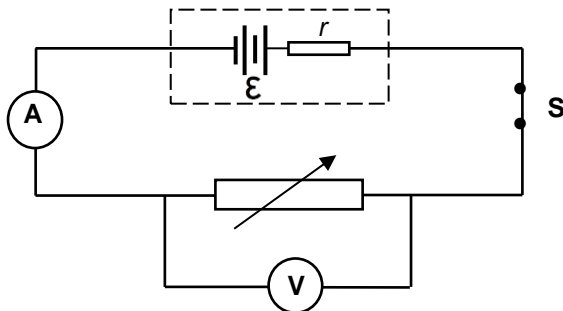

READING ON VOLTMETER (V)	READING ON AMMETER (A)
2	0,58
3	0,46
4	0,36
5	0,24
6	0,14

1.1.1 State ONE factor which must be kept constant during the experiment. (1)

1.1.2 Using the information in the table above, plot the points and draw the line of best fit on a graph paper. (3)

Use the graph drawn in QUESTION 1.1.2 to determine the following:

1.1.3 Emf (ϵ) of the battery (1)

1.1.4 Internal resistance of the battery, WITHOUT USING ANY FORM OF THE EQUATION $\epsilon = I(R + r)$ (3)

1.2 Three electrical devices, **X**, **Y** and **Z**, are connected to a 24 V battery with internal resistance r as shown in the circuit diagram below. The power rating of each of the devices **X** and **Y** are indicated in the diagram.

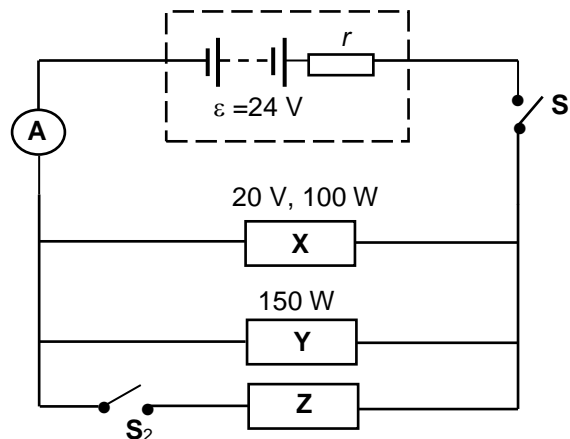

With switch **S**₁ closed and **S**₂ open, the devices function as rated. Calculate the:

1.2.1 Current in **X** (3)

1.2.2 Resistance of **Y** (3)

1.2.3 Internal resistance of the battery (5)

Now switch **S**₂ is also closed.

1.2.4 Identify device **Z** which, when placed in the position shown, can still enable **X** and **Y** to operate as rated. Assume that the resistances of all the devices remain unchanged. (1)

1.2.5 Explain how you arrived at the answer to QUESTION 1.2.4. (2)

[22]

QUESTION 2

2.1 Learners want to construct an electric heater using one of two wires, **A** and **B**, of different resistances. They conduct experiments and draw the graphs as shown.

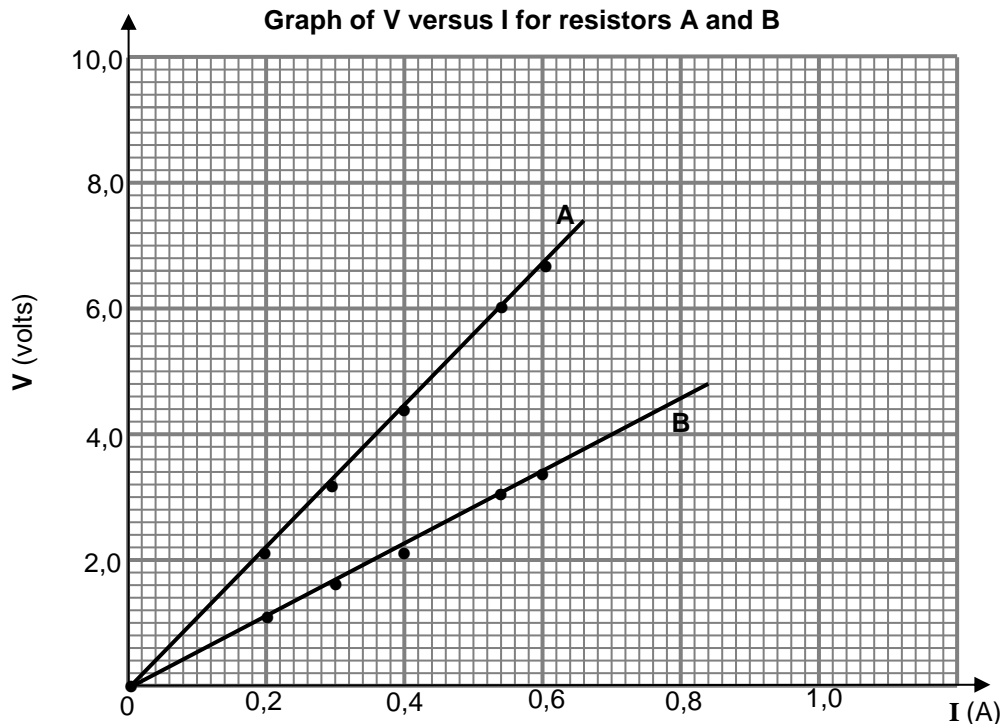

- 2.1.1 Apart from temperature, write down TWO other factors that the learners should consider to ensure a fair test when choosing which wire to use. (2)
- 2.1.2 Assuming all other factors are kept constant, state which ONE of the two wires will be the most suitable to use in the heater. Use suitable calculations to show clearly how you arrive at the answer. (8)

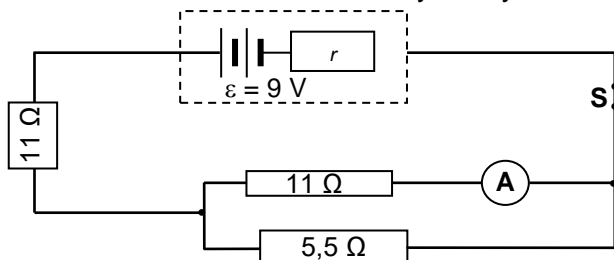

- 2.2 In the circuit alongside the reading on ammeter **A** is 0,2 A. The battery has an emf of 9 V and internal resistance r .
- 2.2.1 Calculate the current through the 5,5 Ω resistor. (3)
- 2.2.2 Calculate the internal resistance of the battery. (7)

2.2.3 Will the ammeter reading INCREASE, DECREASE or REMAIN THE SAME if the 5,5 Ω resistor is removed? Give a reason for the answer. (2) **[22]**

QUESTION 3

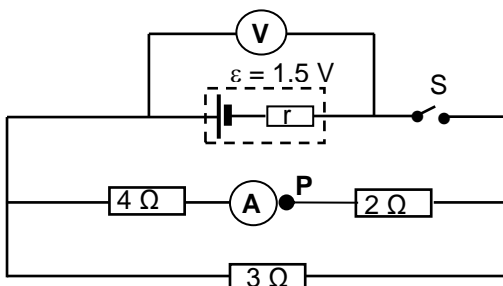

A cell of unknown internal resistance, r , has emf (ϵ) of 1,5 V. It is connected in a circuit to three resistors, a high-resistance voltmeter, a low-resistance ammeter and a switch **S** as shown. When switch **S** is closed, the voltmeter reads 1,36 V.

- 3.1 Which terminal of the ammeter is represented by point **P**? Write down POSITIVE or NEGATIVE. (1)
- 3.2 Calculate the ammeter reading. (3)
- 3.3 Determine the internal resistance of the cell. (7)
- 3.4 An additional resistor **X** is connected parallel to the 3 Ω resistor in the circuit. Will the reading on the ammeter INCREASE, DECREASE or REMAIN UNCHANGED? Give a reason for the answer. (4) **[15]**

QUESTION 4

A battery with an internal resistance of 1Ω and an unknown emf (ϵ) is connected in a circuit, as shown below. A high-resistance voltmeter (V) is connected across the battery. A_1 and A_2 represent ammeters of negligible resistance.

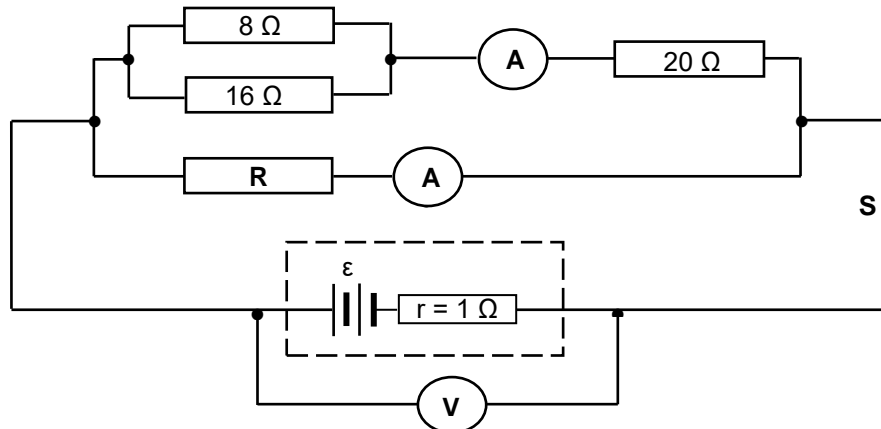

With switch **S** closed, the current passing through the 8Ω resistor is $0,5 \text{ A}$.

- 4.1 State Ohm's law in words. (2)
- 4.2 Calculate the reading on ammeter A_1 . (4)
- 4.3 If device **R** delivers power of 12 W , calculate the reading on ammeter A_2 . (5)
- 4.4 Calculate the reading on the voltmeter when switch **S** is open. (3)

[14]

QUESTION 5

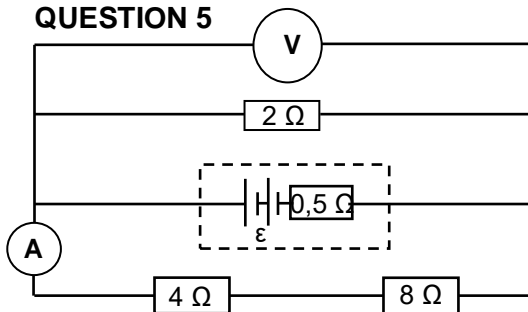

A battery of an unknown emf and an internal resistance of $0,5 \Omega$ is connected to three resistors, a high-resistance voltmeter and an ammeter of negligible resistance, as shown. The reading on the ammeter is $0,2 \text{ A}$.

- 5.1 Calculate the:
 - 5.1.1 Reading on the voltmeter (3)
 - 5.1.2 Total current supplied by the battery (4)
 - 5.1.3 Emf of the battery (5)
- 5.2 How would the voltmeter reading change if the 2Ω resistor is removed? Write down INCREASE, DECREASE or REMAIN THE SAME. Explain the answer. (3)

[15]

QUESTION 6

6.1 In the diagram below, three light bulbs, **A**, **B** and **C**, are connected in parallel to a 12 V source of negligible internal resistance. The bulbs are rated at 4 W , 6 W and 10 W respectively and are all at their maximum brightness.

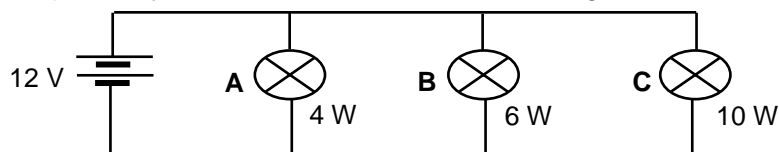

- 6.1.1 Calculate the resistance of the 4 W bulb. (3)
- 6.1.2 How will the equivalent resistance of the circuit change if the 6 W bulb burns out? Write down only INCREASES, DECREASES or NO CHANGE. (1)
- 6.1.3 How will the power dissipated by the 10 W bulb change if the 6 W bulb burns out? Write down only INCREASES, DECREASES or NO CHANGE. Give a reason for the answer. (2)

6.2 A learner connects a high-resistance voltmeter across a battery. The voltmeter reads 6 V. She then connects a $6\ \Omega$ resistor across the battery. The voltmeter now reads 5 V.

6.2.1 Calculate the internal resistance of the battery. (4)

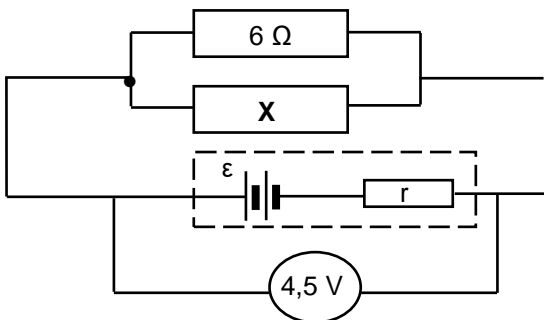

The learner now builds the circuit alongside, using the same 6 V battery and the $6\ \Omega$ resistor. She connects an unknown resistor **X** in parallel with the $6\ \Omega$ resistor. The voltmeter now reads 4,5 V.

6.2.2 Define the term *emf* of a cell. (2)

6.2.3 Calculate the resistance of **X** when the voltmeter reads 4,5 V. (5) [17]

QUESTION 7

7.1 In the circuit below the battery has an emf (ϵ) of 12 V and an internal resistance of $0,2\ \Omega$. The resistances of the connecting wires are negligible.

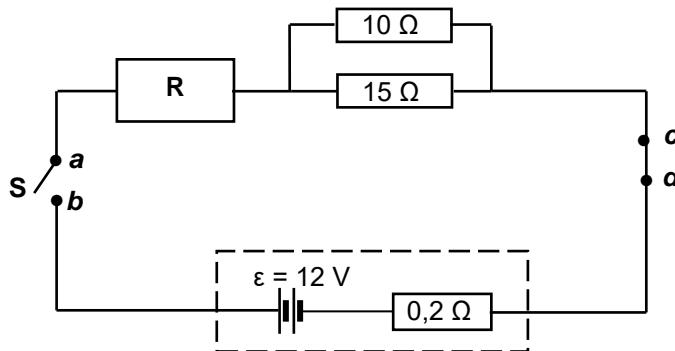

7.1.1 Define the term *emf of a battery*. (2)

7.1.2 Switch **S** is open. A high-resistance voltmeter is connected across points **a** and **b**. What will the reading on the voltmeter be? (1)

7.1.3 Switch **S** is now closed. The same voltmeter is now connected across points **c** and **d**. What will the reading on the voltmeter be? (1)

When switch **S** is closed, the potential difference across the terminals of the battery is 11,7 V. Calculate the:

7.1.4 Current in the battery (3)

7.1.5 Effective resistance of the **parallel** branch (2)

7.1.6 Resistance of resistor **R** (4)

7.2 A battery with an emf of 12 V and an internal resistance of $0,2\ \Omega$ are connected in series to a very small electric motor and a resistor, **T**, of unknown resistance, as shown in the circuit below. The motor is rated **X** watts, 3 volts, and operates at optimal conditions. When switch **S** is closed, the motor lifts a $0,35\ \text{kg}$ mass vertically upwards at a constant speed of $0,4\ \text{m}\cdot\text{s}^{-1}$. Assume that there is no energy conversion into heat and sound.

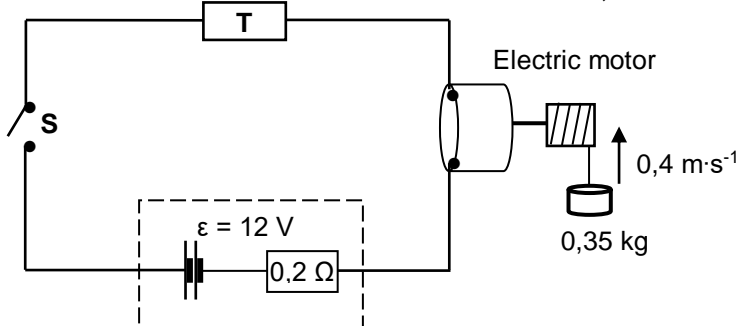

The motor is rated **X** watts, 3 volts, and operates at optimal conditions. When switch **S** is closed, the motor lifts a $0,35\ \text{kg}$ mass vertically upwards at a constant speed of $0,4\ \text{m}\cdot\text{s}^{-1}$. Assume that there is no energy conversion into heat and sound.

7.2.1 Calculate the value of **X**. (3)

7.2.2 Calculate the resistance of resistor **T**. (5) [21]

QUESTION 8

8.1 The emf and internal resistance of a certain battery were determined experimentally. The circuit used for the experiment is shown in the diagram below.

8.1.1 State Ohm's law in words. (2)

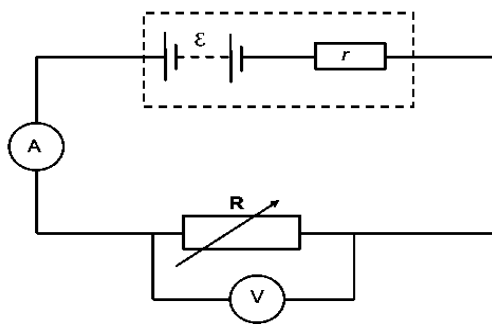

The data obtained from the experiment is plotted on the graph sheet alongside.

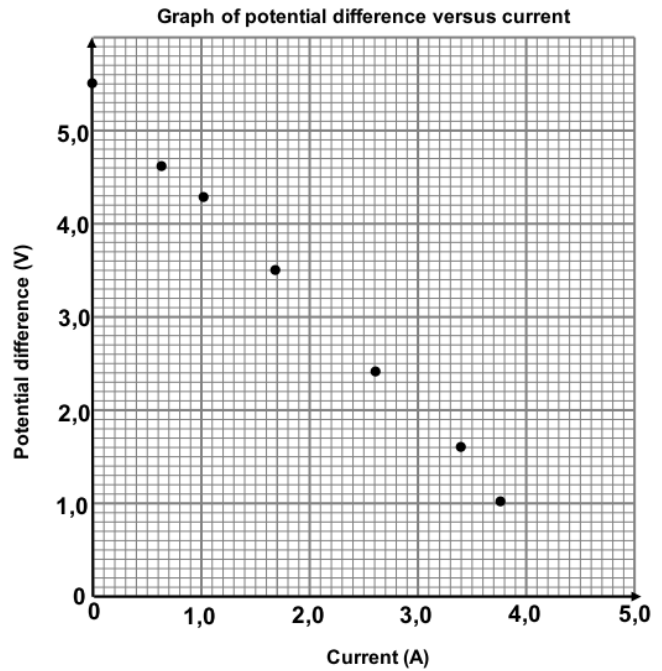

8.1.2 Draw the line of best fit through the plotted points. Ensure that the line cuts both axes. (2)

Use information in the graph to answer QUESTIONS 8.1.3 and 8.1.4.

8.1.3 Write down the value of the emf (ϵ) of the battery. (1)

8.1.4 Determine the internal resistance of the battery. (3)

8.2 The circuit diagram shows a battery with an emf (ϵ) of 60 V and an unknown internal resistance r , connected to three resistors.

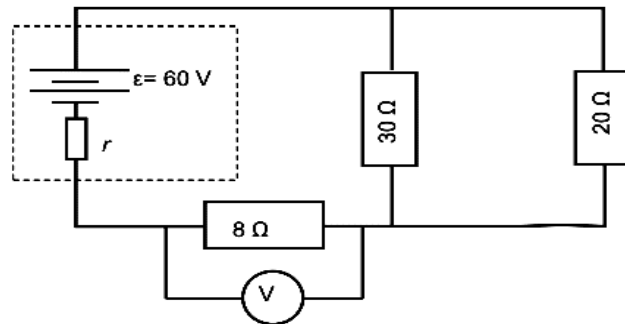

A voltmeter connected across the 8 Ω resistor reads 21,84 V.

Calculate the:

8.2.1 Current in the 8 Ω resistor (3)

8.2.2 Equivalent resistance of the resistors in parallel (2)

8.2.3 Internal resistance r of the battery (4)

8.2.4 Heat dissipated in the external circuit in 0,2 seconds (3)

[20]

QUESTION 9

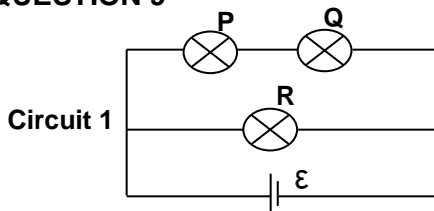

9.1.2 How does the brightness of bulb P compare with that of bulb R? Give a reason. (2)

9.1 In Circuit 1, three identical light bulbs, P, Q and R, with the same resistance, are connected to a battery with emf ϵ and negligible internal resistance.

9.1.1 How does the brightness of bulb P compare with that of bulb Q? Give a reason. (2)

(2)

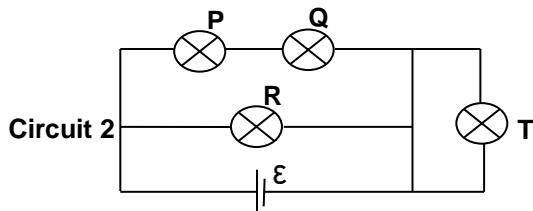

9.1.3 How does the brightness of bulb **T** compare with that of bulb **R**? Give a reason for the answer. (2)

9.2 A battery with an emf of 20 V and an internal resistance of 1 Ω is connected to three resistors, as shown in the circuit below.

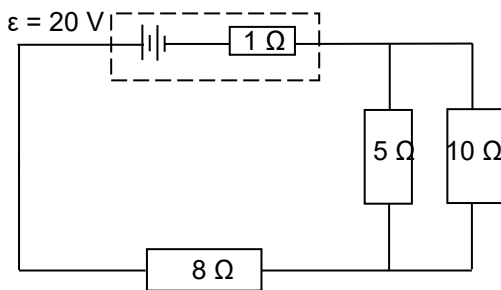

Calculate the:

- 9.2.1 Current in the 8 Ω resistor (6)
 - 9.2.2 Potential difference across the 5 Ω resistor (4)
 - 9.2.3 Total power supplied by the battery (3)
- [19]**

QUESTION 10

GRAPHS OF POTENTIAL DIFFERENCE VERSUS CURRENT FOR THE COMBINATION OF TWO RESISTORS IN SERIES AND IN PARALLEL

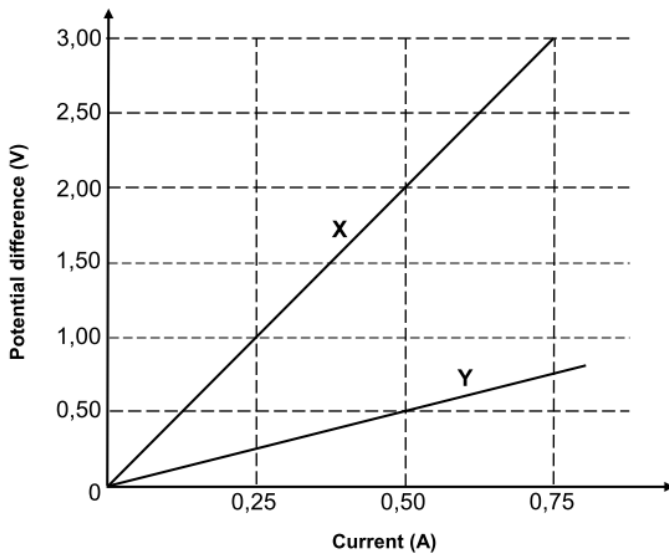

10.1 Learners investigated the relationship between potential difference (V) and current (I) for the combination of two resistors, R_1 and R_2 . In one experiment, resistors R_1 and R_2 were connected in parallel. In a second experiment, resistors R_1 and R_2 were connected in series. The learners then plotted graph **X**, the results of one of the experiments, and graph **Y**, the results of the other experiment, as shown.

- 10.1.1 State Ohm's law in words. (2)
 - 10.1.2 What physical quantity does the gradient (slope) of the V-I graph represent? (1)
 - 10.1.3 Calculate the gradient (slope) of graph **X**. (2)
- (4)

10.1.4 Determine the resistance of resistor R_1 .

10.2 The circuit below consists of three resistors, **M**, **N** and **T**, a battery with emf \mathcal{E} and an internal resistance of 0,9 Ω. The effective resistance between points **a** and **b** in the circuit is 6 Ω. The resistance of resistor **T** is 1,5 Ω.

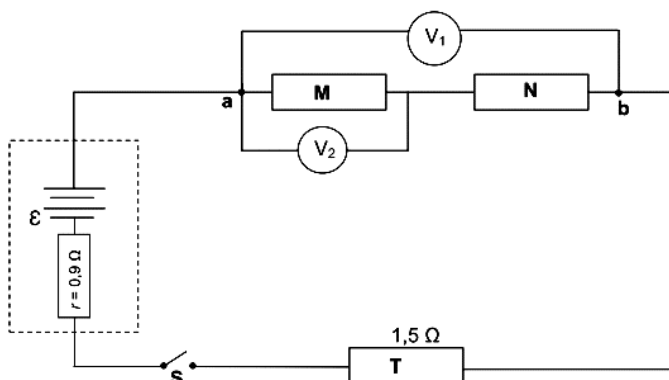

When switch **S** is closed, a high-resistance voltmeter, V_1 , across **a** and **b** reads 5 V. Calculate the:

- 10.2.1 Current delivered by the battery (3)
 - 10.2.2 Emf (\mathcal{E}) of the battery (4)
 - V_2 reads 2,5 V when the switch is closed.
 - 10.2.3 Write down the resistance of **N**. (No calculations required.) Give a reason for the answer. (2)
- [18]**

QUESTION 11

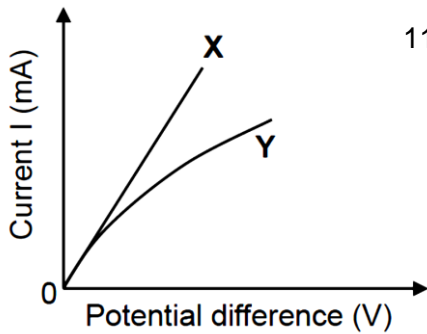

11.1 The two graphs alongside show the relationship between current and potential difference for two different conductors, **X** and **Y**.

11.1.1 State Ohm's law in words. (2)

11.1.2 Which ONE of the two conductors, **X** or **Y**, is ohmic? Refer to the graph and give a reason for the answer. (2)

11.2 In the diagram below, a battery with an emf of 6 V and an internal resistance of 2 Ω, is connected to three resistors **P**, **Q** and **R**. A voltmeter **V** is connected across the battery. The ammeter **A** has a negligible resistance.

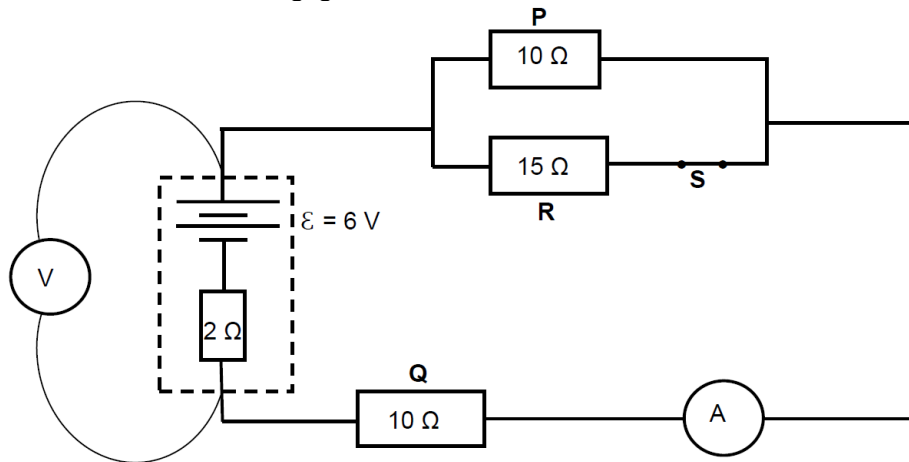

11.2.1 Calculate the ammeter reading when switch **S** is closed. (5)

The switch **S** is now open.

11.2.2 Will the ammeter reading in QUESTION 11.2.1 INCREASE, DECREASE or REMAIN THE SAME? Give a reason for the answer. (2)

11.2.3 How will the voltmeter reading now compare with the voltmeter reading when the switch is closed? Choose from INCREASE, DECREASE or REMAIN THE SAME. (1)

11.2.4 Explain the answer to QUESTION 11.2.3. (3)

[15]

QUESTION 12

12.1 In the circuit diagram below the battery has an unknown emf (ϵ) and an internal resistance (r) of 0,8 Ω.

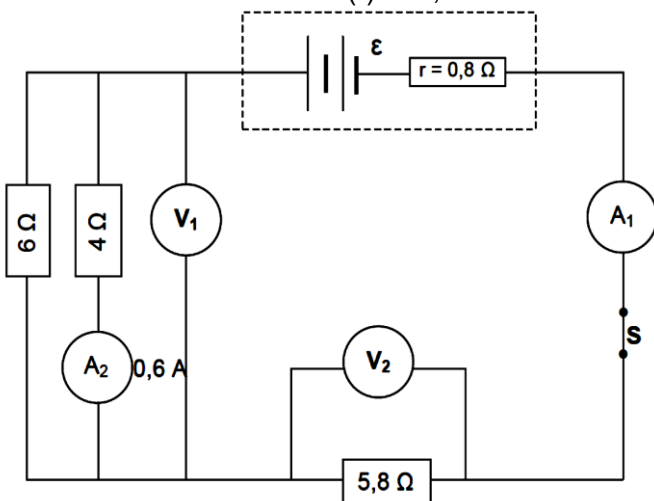

12.1.1 State Ohm's law in words. (2)

The reading on ammeter **A**₂ is 0,6 A when switch **S** is closed. Calculate the:

12.1.2 Reading on voltmeter **V**₁ (3)

12.1.3 Current through the 6 Ω resistor (2)

12.1.4 Reading on voltmeter **V**₂ (2)

12.1.5 Emf (ϵ) of the battery (3)

12.1.6 Energy dissipated as heat inside the battery if the current flows in the circuit for 15 s (3)

12.2 A simplified circuit diagram for the windscreen wiper of a car consists of a variable resistor and a wiper motor connected to a 12 volt battery. When switch **S** is closed, the potential difference across the variable resistor is 2,8 V and the current passing through it is 0,7 A.

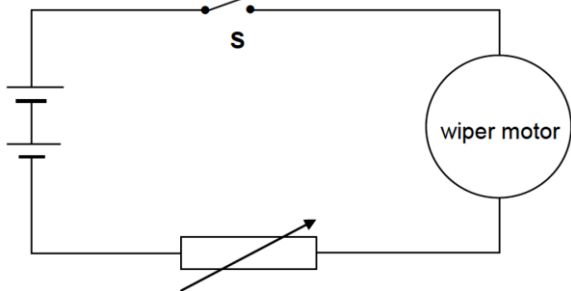

12.2.1 Calculate the resistance of the variable resistor. (2)

The resistance of the variable resistor is now decreased.

12.2.2 State whether the speed at which the wiper turns will INCREASE, DECREASE or REMAIN THE SAME. Give a reason for the answer. (3) [20]

QUESTION 13

The battery in the circuit diagram below has an emf of 12 V and an internal resistance of 0,5 Ω. Resistor **R** has an unknown resistance.

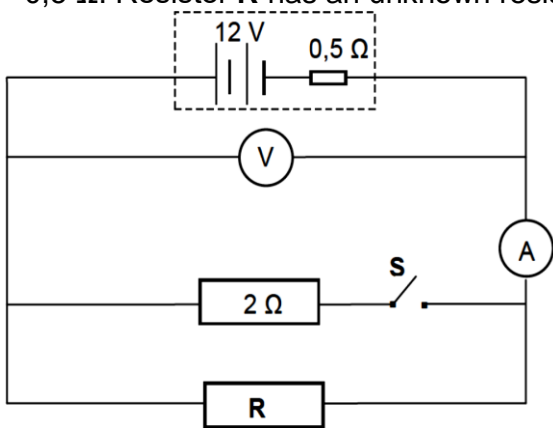

13.1 What is the meaning of the following statement? The emf of the battery is 12 V. (2)

The reading on the ammeter is 2 A when switch **S** is OPEN. Calculate the:

13.2 Reading on the voltmeter (3)

13.3 Resistance of resistor **R** (2)

Switch **S** is now CLOSED.

13.4 How does this change affect the reading on the voltmeter? Choose from: INCREASES, DECREASES or REMAINS THE SAME. Explain the answer. (4) [11]

QUESTION 14

Learners perform an experiment to determine the emf (ϵ) and the internal resistance (r) of a battery using the circuit below. The learners use their recorded readings of current and resistance, together with the equation $R = \frac{\epsilon}{I} - r$, to obtain the graph below.

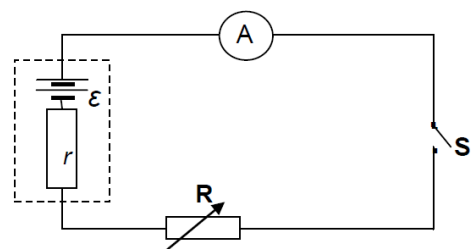
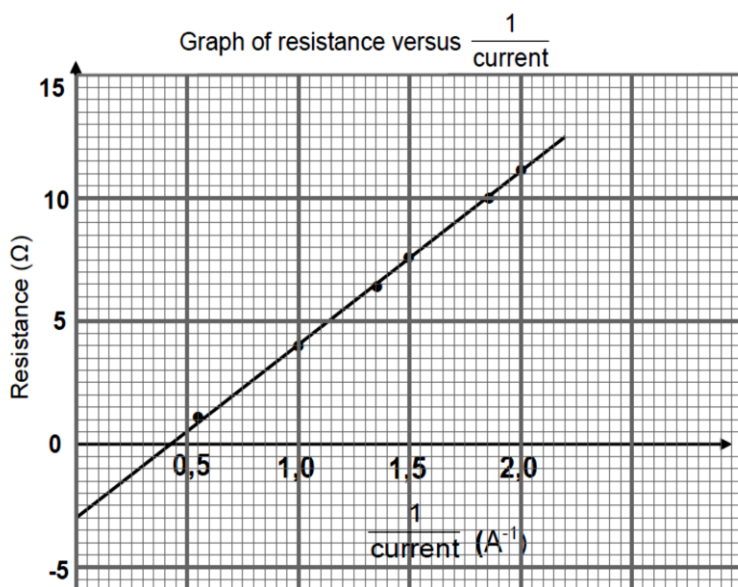

14.1 Which variable has to be kept constant in the experiment? (1)

Refer to the **graph**.

14.2 Write down the value of the internal resistance of the cell. (2)

14.3 Calculate the emf of the battery. (3) [6]

ELECTRICAL MACHINES

QUESTION 1

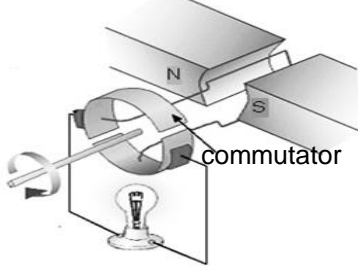

The diagram represents a simplified version of an electrical machine used to light up a bulb.

- 1.1 Name the principle on which the machine operates. (1)
- 1.2 State ONE way in which to make this bulb burn brighter. (1)

Some changes have been made to the machine and a new device is obtained as shown below.

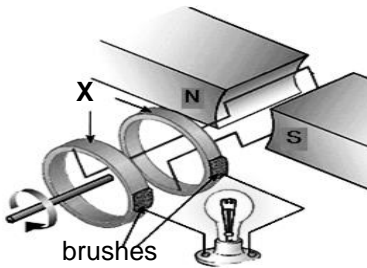

- 1.3 Name part X in the new device. (1)
- 1.4 The graph of output emf versus time obtained using the device in QUESTION 1.3 is shown below.

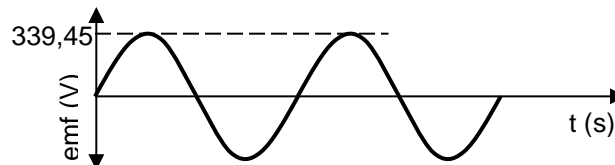

- 1.4.1 Define the term *root mean square value* of an AC voltage. (2)
- 1.4.2 Calculate the rms voltage. (3)

[8]

QUESTION 2

The graph below shows the output voltage from a household AC generator for one cycle of rotation of the coils.

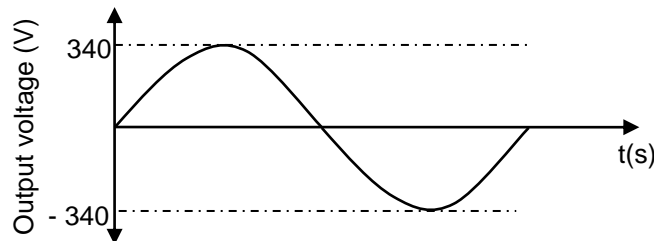

- 2.1 A 100 W light bulb is connected to this generator and it glows at its maximum brightness. Use the information from the graph to calculate the:
 - 2.1.1 Resistance of the bulb (5)
 - 2.1.2 rms current through the bulb (3)
- 2.2 Give ONE reason why AC voltage is preferred to DC voltage for everyday use. (1)

[9]

QUESTION 3

- 3.1 The output potential difference of an AC generator is 100 V at 20 Hz. A simplified diagram of the generator is shown below. The direction of the current in the coil is from a to b.

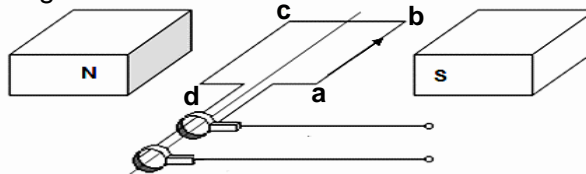

- 3.1.1 In which direction is the coil rotating? Write only CLOCKWISE or ANTICLOCKWISE. (1)
- 3.1.2 Starting from the position shown in the diagram, sketch a graph of the output potential difference versus time when the coil completes TWO full cycles. On the graph, clearly indicate the maximum potential difference (100 V) and the time taken to complete the two cycles. (3)

3.1.3 State ONE way in which this AC generator can be used to produce a lower output potential difference. (1)

3.2 An electrical device is rated 220 V, 1 500 W. Calculate the maximum current output for the device when it is connected to a 220 V alternating current source. (5) [10]

QUESTION 4

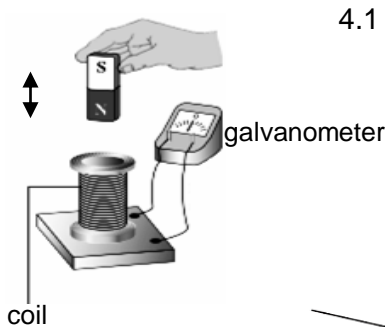

4.1 A teacher demonstrates how current can be obtained using a bar magnet, a coil and a galvanometer. The teacher moves the bar magnet up and down, as shown by the arrow in the diagram.

4.1.1 Briefly describe how the magnet must be moved in order to obtain a LARGE deflection on the galvanometer. (2)

The two devices, **A** and **B**, below operate on the principle described in QUESTION 4.1.1 above.

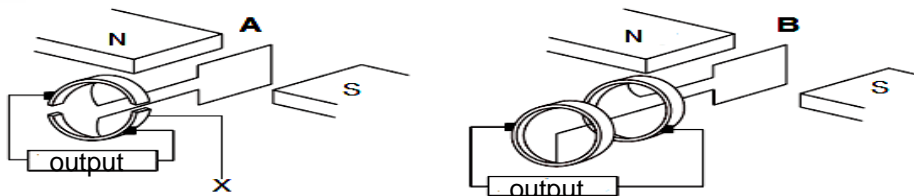

4.1.2 Write down the name of the principle. (1)

4.1.3 Write down the name of part **X** in device **A**. (1)

4.2 A 220 V, AC voltage is supplied from a wall socket to an electric kettle of resistance 40,33 Ω. Wall sockets provide rms voltages and currents. Calculate the:

4.2.1 Electrical energy consumed by the kettle per second (4)

4.2.2 Maximum (peak) current through the kettle (3) [11]

QUESTION 5

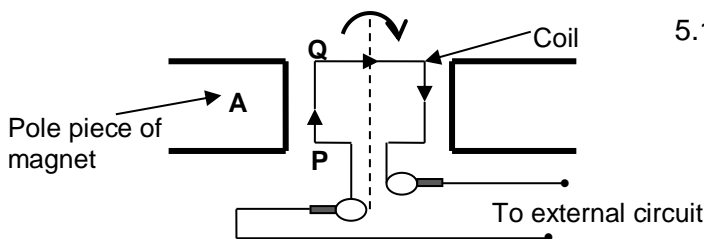

5.1 A simplified sketch of an AC generator is shown. The coil of the generator rotates clockwise between the pole pieces of two magnets. At a particular instant, the current in the segment **PQ** has the direction shown.

5.1.1 Identify the magnetic pole **A**. Only write NORTH POLE or SOUTH POLE. (1)

5.1.2 The coil is rotated through 180°. Will the direction of the current in segment **PQ** be from **P** to **Q** or **Q** to **P**? (1)

5.2 An electrical device is connected to a generator which produces an rms potential difference of 220 V. The maximum current passing through the device is 8 A. Calculate the:

5.2.1 Resistance of the device (5)

5.2.2 Energy the device consumes in two hours (5) [12]

QUESTION 6

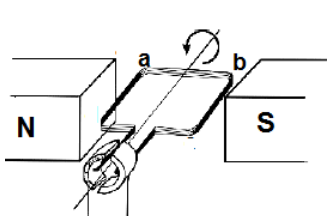

6.1 A part of a simplified DC motor is shown in the sketch.

6.1.1 In which direction (**a** to **b**, OR **b** to **a**) is the current flowing through the coil if the coil rotates anticlockwise as indicated in the diagram? (1)

6.1.2 Name the rule you used to answer QUESTION 6.1.1. (1)

- 6.1.3 Which component in the diagram must be replaced in order for the device to operate as an AC generator? (1)
- 6.2 An electrical device of resistance $400\ \Omega$ is connected across an AC generator that produces a maximum emf of $430\ \text{V}$. The resistance of the coils of the generator can be ignored.
- 6.2.1 State the energy conversion that takes place when the AC generator is in operation. (2)
- 6.2.2 Calculate the root mean square value of the current passing through the resistor. (5)
- [10]**

QUESTION 7

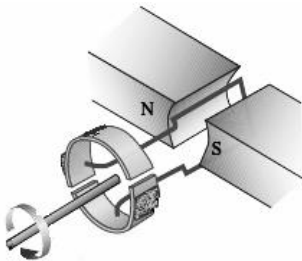

- 7.1 A generator is shown below. Assume that the coil is in a vertical position.
- 7.1.1 Is the generator above AC or DC? Give a reason for the answer. (2)
- 7.1.2 Sketch an induced emf versus time graph for ONE complete rotation of the coil. (The coil starts turning from the vertical position.) (2)

- 7.2 An AC generator is operating at a maximum emf of $340\ \text{V}$. It is connected across a toaster and a kettle, as shown in the diagram below.

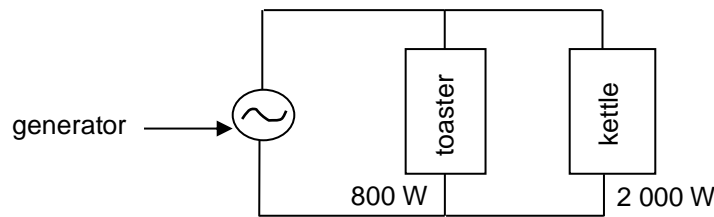

The toaster is rated at $800\ \text{W}$, while the kettle is rated at $2\ 000\ \text{W}$. Both are working under optimal conditions. Calculate the:

- 7.2.1 rms current passing through the toaster (3)
- 7.2.2 Total rms current delivered by the generator (4)
- [11]**

QUESTION 8

- 8.1 The diagram below shows a simplified version of a generator.

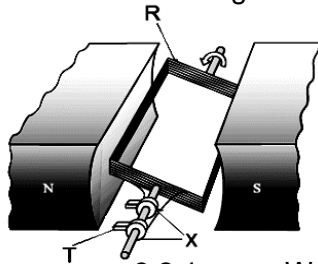

- 8.1.1 Write down the name of EACH part, R, T and X. (3)
- 8.1.2 Give the NAME of the law upon which the operation of the generator is based. (1)
- 8.2 An AC supply is connected to a light bulb. The light bulb lights up with the same brightness as it does when connected to a $15\ \text{V}$ battery.

- 8.2.1 Write down the rms value of the potential difference of the AC supply. (1)
- 8.2.2 If the resistance of the light bulb is $45\ \Omega$, calculate the maximum current delivered to the light bulb. (4)
- [9]**

QUESTION 9

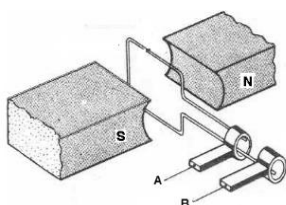

The diagram below shows a simplified version of an AC generator.

- 9.1 Name the component in this arrangement that makes it different from a DC generator. (1)
- 9.2 Sketch a graph of induced emf versus time for TWO complete rotations of the coil. (2)

A practical version of the generator above has a large number of turns of the coil and it produces an rms potential difference of 240 V.

- 9.3 State TWO ways in which the induced emf can be increased. (2)
- 9.4 Define the term *root mean square (rms) value* of an AC potential difference. (2)
- 9.5 The practical version of the generator above is connected across an appliance rated at 1 500 W. Calculate the rms current passing through the appliance. (3)

[10]

QUESTION 10

- 10.1 The diagram below shows different positions (ABCD) of the coil in a DC generator for a complete revolution. The coil is rotated clockwise at a constant speed in a uniform magnetic field. The direction of the magnetic field is shown in the diagram below.

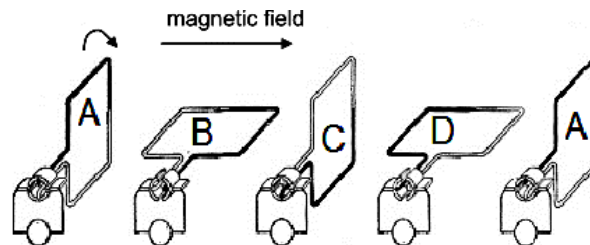

- 10.1.1 Write down the energy conversion that takes place during the operation of the DC generator. (1)
- 10.1.2 Sketch a graph to show how the induced emf of the generator varies with time. Clearly indicate positions **A**, **B**, **C**, **D** and **A** on the graph. (2)
- 10.2 A small AC generator, providing an rms voltage of 25 V, is connected across a device with a resistance of 20 Ω . The wires connecting the generator to the device have a total resistance of 0,5 Ω . Refer to the diagram below.

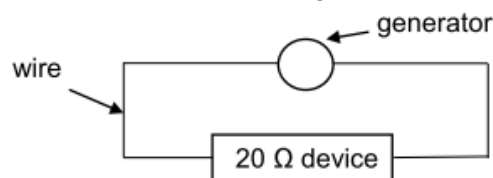

- 10.2.1 Write down the total resistance of the circuit. (1)
- 10.2.2 Calculate the average power delivered to the device. (5)

[9]

QUESTION 11

- 11.1 Learners want to build a small **DC** motor as a project. Write down THREE essential components that are needed for the building of the motor. (3)
- 11.2 An electrical device with a resistance of 11 Ω is connected to an **AC** source with an rms voltage of 240 V.
- 11.2.1 Define the term *rms voltage*. (2)
- 11.2.2 Calculate the maximum (peak) current passing through the device. (4)

[9]

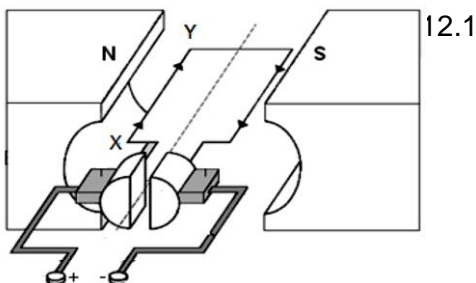
QUESTION 12

- 12.1 The diagram is a simplified representation of a DC motor. The current in the coil is in the direction XY.
- 12.1.1 Name the component that ensures that the coil rotates continuously in ONE DIRECTION. (1)
- 12.1.2 In which direction will the coil rotate? Write down only **CLOCKWISE** or **ANTICLOCKWISE**. (2)

- 12.1.3 Write down the energy conversion which takes place while the motor is working. (2)
- 12.2 An AC generator, producing a maximum voltage of 320 V, is connected to a heater of resistance 35Ω .
- 12.2.1 Write down the structural difference between an AC generator and a DC generator. (1)
- 12.2.2 Calculate the root mean square (rms) value of the voltage. (3)
- 12.2.3 Calculate the root mean square (rms) value of the current in the heater. (4)

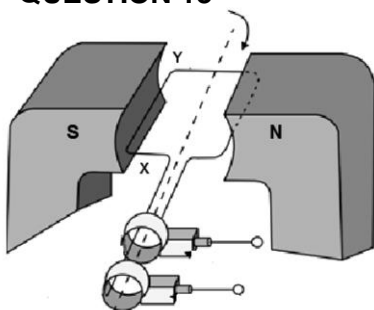
[13]**QUESTION 13**

- 13.1 In the simplified AC generator, the coil is rotated clockwise
- 13.1.1 In which direction does the induced current flow in the coil? Choose from: **X to Y** or **Y to X**. (1)
- 13.1.2 On which principle or law is the working of the generator based? (1)
- 13.1.3 State the energy conversion that takes place while the generator is in operation. (2)

- 13.2 The voltage output for an AC generator is shown below

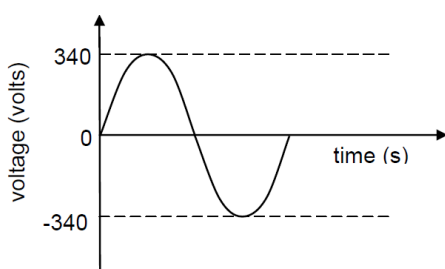

- 13.2.1 Write down the maximum (peak) output voltage of the generator. (1)

A stove is connected to the generator above, and delivers an average power of 1 600 W.

- 13.2.2 Calculate the rms voltage delivered to the stove. (3)
- 13.2.3 Calculate the resistance of the stove. (3)

[11]**OPTICAL PHENOMENA AND PROPERTIES OF MATERIALS****QUESTION 1**

Ultraviolet light is incident onto a photocell with a potassium cathode as shown below. The threshold frequency of potassium is $5,548 \times 10^{14}$ Hz.

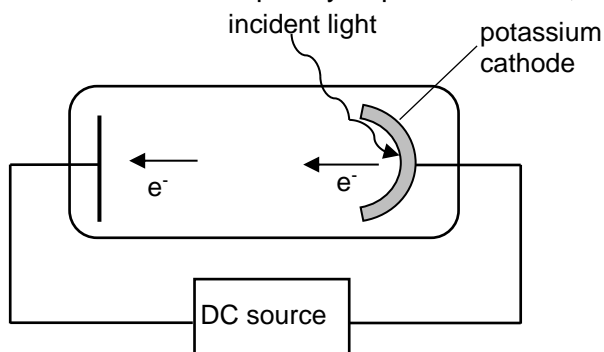

- 1.2 Define the term *threshold frequency (cut-off frequency)*. (2)

The maximum speed of an ejected photoelectron is $5,33 \times 10^5 \text{ m}\cdot\text{s}^{-1}$.

- 1.2 Calculate the wavelength of the ultraviolet light used. (5)

The photocell is now replaced by another photocell with a rubidium cathode. The maximum speed of the ejected photoelectron is $6,10 \times 10^5 \text{ m}\cdot\text{s}^{-1}$ when the same ultraviolet light source is used.

- 1.3 How does the work function of rubidium compare to that of potassium? Write down only **GREATER THAN**, **SMALLER THAN** or **EQUAL TO**. (1)
- 1.4 Explain the answer to QUESTION 1.3. (3)

[11]

QUESTION 2

A learner uses photocells to determine the maximum kinetic energy of ejected photoelectrons. One photocell has a caesium cathode and the other has a sodium cathode. Each photocell is radiated by ultraviolet light from the same source as shown below.

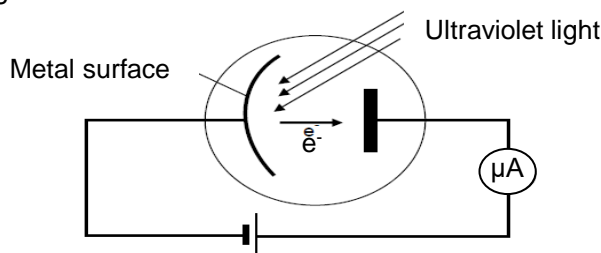

The incomplete results obtained are shown in the table below.

NAME OF THE METAL	WORK FUNCTION OF THE METAL (J)	MAXIMUM KINETIC ENERGY OF PHOTOELECTRONS (J)
Caesium	$3,36 \times 10^{-19}$	$2,32 \times 10^{-19}$
Sodium	$3,65 \times 10^{-19}$	E_k

- 2.1 Define the term *work function of a metal*. (2)
- 2.2 Use the information in the table to calculate the wavelength of the ultraviolet light used in the experiment. (4)
- 2.3 Calculate the maximum kinetic energy, E_k , of an electron ejected from the sodium metal. (4)
- 2.4 The intensity of the incident ultraviolet light was then increased.
- 2.4.1 Give a reason why this change does NOT affect the maximum kinetic energy of the ejected photoelectrons. (1)
- 2.4.2 How does the increased intensity affect the reading on the ammeter? Write down only INCREASES, DECREASES or REMAINS THE SAME. (1)
- 2.4.3 Explain the answer to QUESTION 2.4.2. (2)

[14]**QUESTION 3**

- 3.1 In the diagram below, green and blue light are successively shone on a metal surface. In each case, electrons are ejected from the surface.



- 3.1.1 What property of light is illustrated by the photoelectric effect? (1)
- 3.1.2 Without any calculation, give a reason why the maximum kinetic energy of an ejected electron, using blue light, is GREATER THAN that obtained using green light, for the same metal surface. (2)
- 3.2 The wavelength associated with the cut-off (threshold) frequency of a certain metal is 330 nm. Calculate:
- 3.2.1 The work function of the metal (4)
- 3.2.2 The maximum speed of an electron ejected from the surface of the metal when light of frequency $1,2 \times 10^{15}$ Hz is shone on the metal (5)

[12]

QUESTION 4

In an experiment to demonstrate the photoelectric effect, light of different wavelengths was shone onto a metal surface of a photoelectric cell. The maximum kinetic energy of the emitted electrons was determined for the various wavelengths and recorded in the table below.

INVERSE OF WAVELENGTH $\frac{1}{\lambda}$ ($\times 10^6 \text{ m}^{-1}$)	MAXIMUM KINETIC ENERGY $E_{k(\text{max})}$ ($\times 10^{-19} \text{ J}$)
5,00	6,60
3,30	3,30
2,50	1,70
2,00	0,70

4.1 What is meant by the term *photoelectric effect*? (2)

4.2 Draw a graph of $E_{k(\text{max})}$ (y-axis) versus $\frac{1}{\lambda}$ (x-axis) on a graph paper. (3)

4.3 USE THE GRAPH to determine:

4.3.1 The threshold frequency of the metal in the photoelectric cell (4)

4.3.2 Planck's constant (4)

[13]

QUESTION 5

An investigation was conducted to determine the effects of changes in frequency AND intensity on the current generated in a photoelectric cell when light is incident on it. The apparatus used in the investigation is shown in the simplified diagram below.

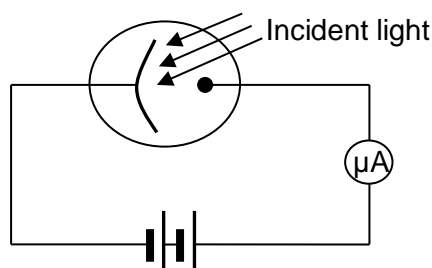

The results of the experiment are shown in the table below.

EXPERIMENT	FREQUENCY (Hz)	INTENSITY (Cd)	CURRENT (μA)
A	$4,00 \times 10^{14}$	10	0
B	$4,50 \times 10^{14}$	10	0
C	$5,00 \times 10^{14}$	10	0
D	$5,01 \times 10^{14}$	10	20
E	$5,01 \times 10^{14}$	20	40
F	$6,50 \times 10^{14}$	10	30

5.1 Define the term *work function*. (2)

5.2 Identify an independent variable. (1)

The threshold frequency for the metal used in the photocell is $5,001 \times 10^{14} \text{ Hz}$.

5.3 Define the term *threshold frequency*. (2)

5.4 Calculate the maximum speed of an emitted electron in experiment F. (5)

In experiments D and E, the current doubled when the intensity was doubled at the same frequency.

5.5 What conclusion can be made from this observation? (2)

[12]

QUESTION 6

6.1 In an experiment on the photoelectric effect, light is incident on the surface of a metal and electrons are ejected.

6.1.1 What does the photoelectric effect indicate about the nature of light? (1)

6.1.2 The intensity of the light is increased. Will the maximum speed of the ejected electrons INCREASE, DECREASE or REMAIN THE SAME? Give a reason for the answer. (2)

The wavelength corresponding with the threshold frequency is referred to as *threshold wavelength*. The table below gives the values of threshold wavelengths for three different metals.

METAL	THRESHOLD WAVELENGTH (λ_0) IN METRES
Silver	$2,88 \times 10^{-7}$
Calcium	$4,32 \times 10^{-7}$
Sodium	$5,37 \times 10^{-7}$

In the experiment using one of the metals above, the maximum speed of the ejected electrons was recorded as $4,76 \times 10^5 \text{ m}\cdot\text{s}^{-1}$ for light of wavelength 420 nm.

6.1.3 Identify the metal used in the experiment by means of suitable calculations. (5)

6.2 The simplified energy diagrams showing the possible electron transitions in an atom are shown below.

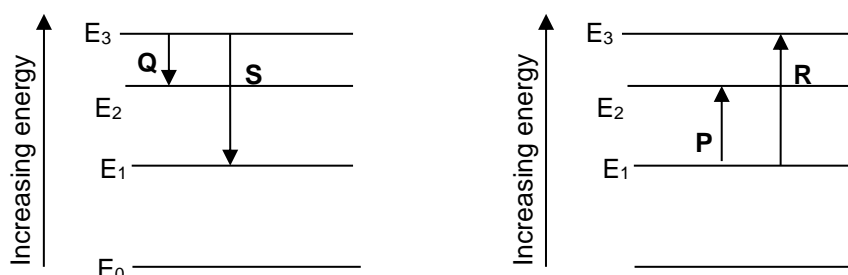

Using the letters **P**, **Q**, **R** and **S**, identify the lines that CORRECTLY show transitions that will result in the atom giving off an EMISSION SPECTRUM. Give a reason for the answer. (4)

[12]

QUESTION 7

7.1 A learner is investigating the photoelectric effect for two different metals, silver and sodium, using light of different frequencies. The maximum kinetic energy of the emitted photoelectrons is plotted against the frequency of the light for each of the metals, as shown in the graphs below.

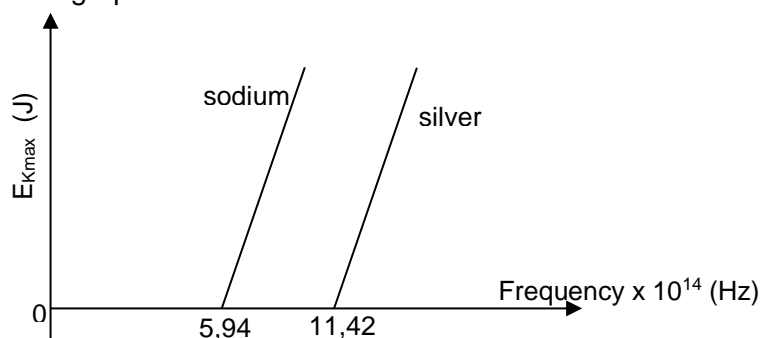

7.1.1 Define the term *threshold frequency*. (2)

7.1.2 Which metal, sodium or silver, has the larger work function? Explain the answer. (3)

- 7.1.3 Name the physical constant represented by the slopes of the graphs. (1)
- 7.1.4 If light of the same frequency is shone on each of the metals, in which metal will the ejected photoelectrons have a larger maximum kinetic energy? (1)
- 7.2 In a different photoelectric experiment blue light obtained from a light bulb is shone onto a metal plate and electrons are released. The wavelength of the blue light is $470 \times 10^{-9} \text{ m}$ and the bulb is rated at 60 mW. The bulb is only 5% efficient.
- 7.2.1 Calculate the number of photons that will be incident on the metal plate per second, assuming all the light from the bulb is incident on the metal plate. (5)
- 7.2.2 **Without any further calculation**, write down the number of electrons emitted per second from the metal. (1)
- [13]**

QUESTION 8

A simplified diagram of an apparatus for an experiment to investigate the photoelectric effect is shown below. Light of a fixed frequency is incident on the cathode of a photoelectric tube. During the experiment the ammeter (A) registers the photocurrent.

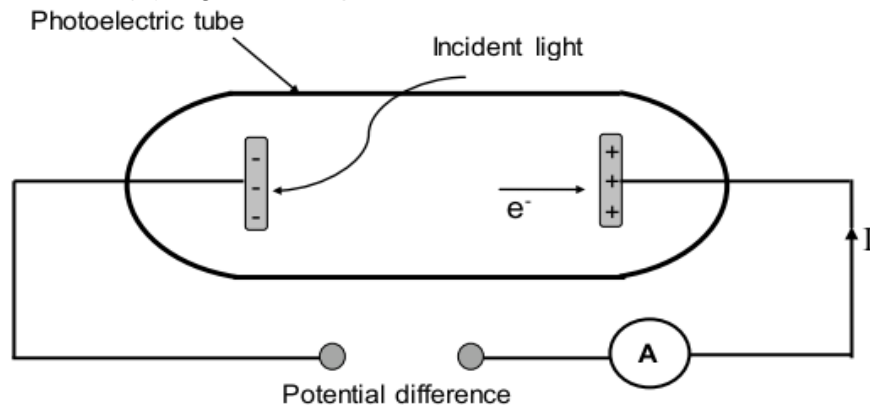

- 8.1 Define the term photoelectric effect. (2)
- The intensity of the incident light is now increased.
- 8.2 State how this increase in intensity will affect the reading on the ammeter. Choose from INCREASE, DECREASE or REMAIN THE SAME. Give a reason for the answer. (3)
- When the frequency of the incident light is $5,9 \times 10^{14} \text{ Hz}$, the maximum recorded kinetic energy of photoelectrons is $2,9 \times 10^{-19} \text{ J}$.
- 8.3 Calculate the maximum wavelength (threshold wavelength) of the incident light that will emit an electron from the cathode of the photo-electric tube. (5)
- The maximum kinetic energy of the photoelectrons ejected increases when light of a higher frequency is used.
- 8.4 Use the photoelectric equation to explain this observation. (2)
- [12]**

QUESTION 9

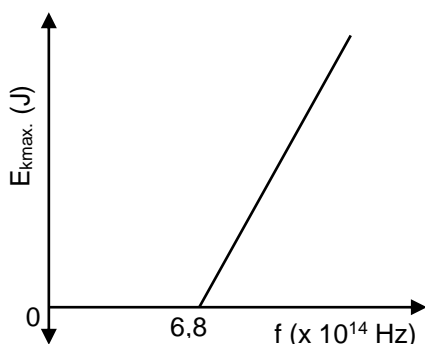

The graph is obtained for an experiment on the photoelectric effect using different frequencies of light and a given metal plate. The threshold frequency for the metal is $6,8 \times 10^{14} \text{ Hz}$.

- 9.1 Define the term *threshold frequency*. (2)
- In the experiment, the brightness of the light incident on the metal surface is increased.
- 9.2 State how this change will influence the speed of the photoelectrons emitted. Choose from INCREASES, DECREASES or REMAINS UNCHANGED. (1)

- 9.3 Show by means of a calculation whether the photoelectric effect will be OBSERVED or NOT OBSERVED, if monochromatic light with a wavelength of $6 \times 10^{-7} \text{ m}$ is used in this experiment. (5)

One of the radiations used in this experiment has a frequency of $7,8 \times 10^{14} \text{ Hz}$.

- 9.4 Calculate the maximum speed of an ejected photoelectron. (5)
[13]

QUESTION 10

- 10.1 A teacher in a science class explains how different types of spectra are obtained. The teacher uses the simplified diagrams shown below for the explanation.

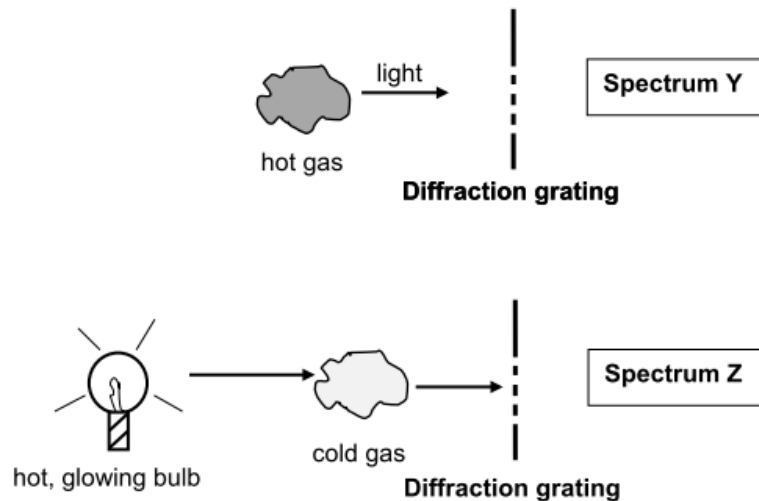

Name the type of spectrum of:

- 10.1.1 **Y** (1)
- 10.1.2 **Z** (1)

- 10.2 In an excited atom, electrons can 'jump' from lower energy levels to higher energy levels. They can also 'drop' from higher energy levels to lower energy levels. The diagram below (not drawn to scale) shows some of the transitions for electrons in an excited atom.

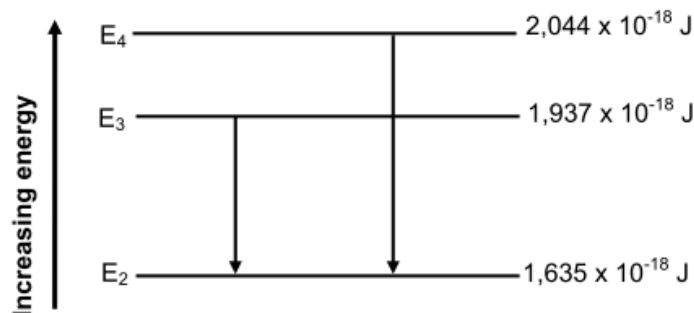

- 10.2.1 Do the transitions indicated in the diagram lead to ABSORPTION or EMISSION spectra? (1)
- 10.2.2 Calculate the frequency of the photon produced when an electron in an excited atom makes a transition from E_4 to E_2 , as shown in the diagram. (4)

The threshold frequency of a metal, **Q**, is $4,4 \times 10^{14} \text{ Hz}$.

- 10.2.3 Calculate the kinetic energy of the most energetic electron ejected when the photon produced in QUESTION 10.2.2 is incident on the surface of metal **Q**. (4)

Another metal, **R**, has a threshold frequency of $7,5 \times 10^{14}$ Hz.

- 10.2.4 Will the photon produced in QUESTION 10.2.2 be able to eject electrons from the surface of metal **R**? Write down only YES or NO. Give a reason for the answer.

(2)
[13]

QUESTION 11

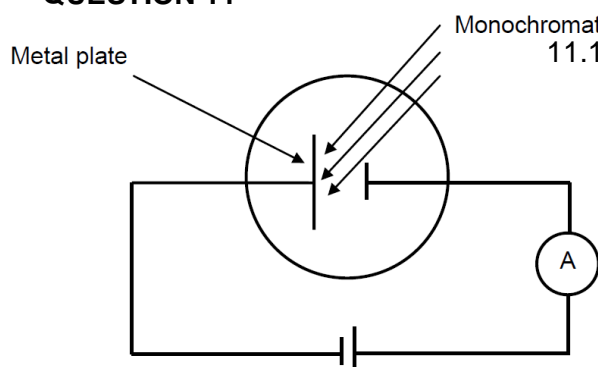

- 11.1 In the diagram, monochromatic light is incident on the metal plate of a photocell. A sensitive ammeter shows a reading.

- 11.1.1 How does the energy of the photons of the incident light compare to the work function of the metal plate? Choose from GREATER THAN, LESS THAN or EQUAL TO. Give a reason for the answer.

(2)

- 11.1.2 When a change is made to the monochromatic light, the reading on the ammeter increases. A learner makes the following statement with regard to this change:
The increase in the ammeter reading is due to an increase in the energy of the incident photons.
Give a reason why this statement is INCORRECT.

(2)

- 11.1.3 What does the photoelectric effect tell us about the nature of light?

(1)

- 11.2 Ultraviolet radiation is incident on the surface of sodium metal. The threshold frequency (f_0) for sodium is $5,73 \times 10^{14}$ Hz. The maximum speed of an electron emitted from the metal surface is $4,19 \times 10^5$ m·s⁻¹.

- 11.2.1 Define or explain the term *threshold frequency*.

(2)

- 11.2.2 Calculate the work function of sodium.

(3)

- 11.2.3 Calculate the frequency of the incident photon.

(3)

[13]

QUESTION 12

A group of students investigates the relationship between the work function of different metals and the maximum kinetic energy of the ejected electrons when the metals are irradiated with light of suitable frequency.

- 12.1 Define the term *work function*.

(2)

During the investigation ultraviolet rays of wavelength 2×10^{-8} m are allowed to fall on different metal plates. The corresponding maximum kinetic energies of ejected electrons are measured. The data obtained is displayed in the table below.

METAL PLATE USED	MAXIMUM KINETIC ENERGY ($E_{k(max)}$) ($\times 10^{-18}$ J)
Lead	9,28
Potassium	9,58
Silver	9,19

- 12.2 Write down the dependent variable for this investigation.

(1)

- 12.3 Write down ONE control variable for this investigation.

(1)

- 12.4 Using the information in the table, and without any calculation, identify the metal with the largest work function. Explain the answer.

(3)

- 12.5 Use information in the table to calculate the work function of potassium.

(4)

- 12.6 State how an increase in the intensity of the ultraviolet light affects the maximum kinetic energy of the photoelectrons. Choose from: INCREASES, DECREASES, REMAINS THE SAME. Explain the answer.

(3)
[14]**QUESTION 13**

The threshold frequencies of caesium and potassium metals are given in the table below.

METAL	THRESHOLD FREQUENCY
Caesium	$5,07 \times 10^{14}$ Hz
Potassium	$5,55 \times 10^{14}$ Hz

- 13.1 Define the term *work function* in words. (2)
- 13.2 Which ONE of the two metals in the table has the higher work function? Give a reason for the answer by referring to the information in the table. (2)

The simplified diagrams below show two circuits, **A** and **B**, containing photocells. The photocell in circuit **A** contains a caesium metal plate, while the photocell in circuit **B** contains a potassium metal plate. Ultraviolet light with the same intensity and wavelength of $5,5 \times 10^{-7}$ m is incident on the metal plate in EACH of the photocells and the ammeter in circuit **A** registers a current.

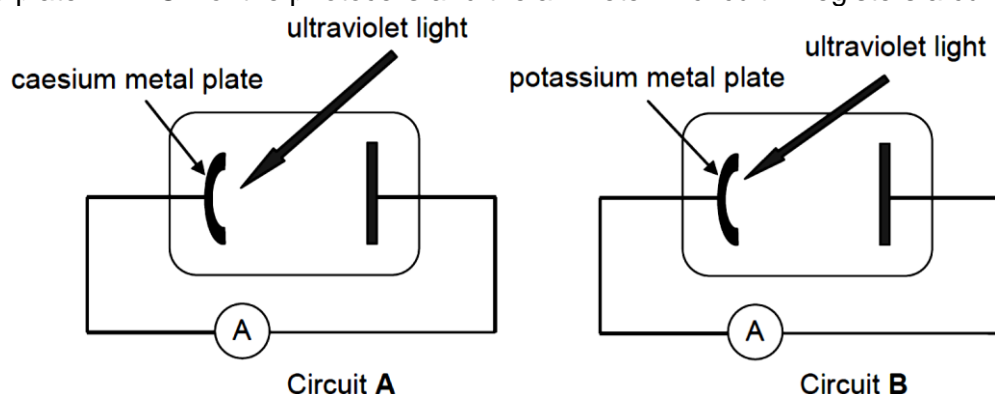

- 13.3 By means of a calculation, determine whether the ammeter in circuit **B** will also register a current. (3)
- 13.4 Calculate the maximum kinetic energy of an ejected electron in circuit **A**. (5)
- 13.5 How will the maximum kinetic energy of the ejected electron, calculated in QUESTION 13.4, change when the intensity of the incident light increases? Choose from: INCREASES, DECREASES or REMAINS THE SAME. (1)

[13]

ANSWERS TO QUESTIONS

NEWTON'S LAWS

QUESTION 1

1.1 When a resultant (net) force acts on an object, the object will accelerate in the direction of the force with an acceleration which is directly proportional to the force ✓ and inversely proportional to the mass of the object. ✓ (2)

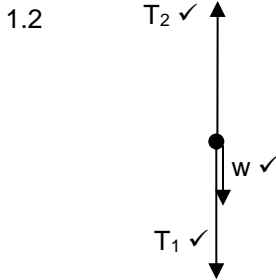

Accepted labels	
w	F _g / F _w / force of earth on block / weight / 49 N / mg / gravitational force
T ₂	Tension 2 / F _Q / 250 N / F _{T2} / F _{app}
T ₁	Tension 1 / F _{T1} / F _P

(3)

1.3 $F_{net} = ma$ ✓
 For 5 kg block:
 $T_2 + (-mg) + (-T_1) = ma$
 $250 - (5)(9,8) - T_1 = 5a$ ✓
 $201 - T_1 = 5a$
 $T_1 = 201 - 5a$ (1)
 For 20 kg block:
 $T_1 + (-mg) = ma$ (2)
 $T_1 + [-20(9,8)] = 20a$ ✓

✓ for either 5a or 20a

$5 = 25a$ $a = 0,2 \text{ m}\cdot\text{s}^{-2}$ upwards
 $\therefore T_1 = 201 - 5(0,2) = 200 \text{ N}$ ✓ OR $T_1 = 20(9,8) + 20(0,2) = 200 \text{ N}$ ✓

(6)

1.4 Q ✓

(1)

[12]

QUESTION 2

2.1 When body A exerts a force on body B, body B exerts a force of equal magnitude ✓ in the opposite direction ✓ on body A. (2)

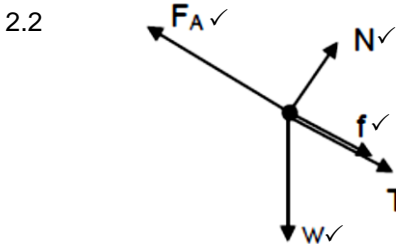

Accepted labels	
w	F _g / F _w / force of earth on block / weight / mg / gravitational force
N	Normal force / F _N
T	Tension / F _T
F _A	F / F _{applied} / 40 N
f	Frictional force / F _f

(5)

2.3

2.3.1 **OPTION 1/OPSIE 1**
 For the 1 kg block / Vir die 1 kg blok;
 $f_k = \mu_k N$
 $= \mu_k mg \cos \theta$
 $= 0,29 (1 \times 9,8 \cos 30^\circ)$ ✓
 $= 2,46 \text{ N}$ ✓

OPTION 2/OPSIE 2
 BY PROPORTION: / DEUR EWEREDIGHEID
 The smaller mass = 1/4 of the larger mass ✓
 Die kleiner massa = 1/4 die groter massa
 \therefore frictional force / wrywingskrag = 1/4 (10) ✓
 $= 2,5 \text{ N}$ ✓

(3)

2.3.2 $F_{net} = ma$ ✓

For 1 kg block / Vir 1 kg blok
 $F_A - \{(T + f_k) + mg \sin \theta\} = ma$
 $40 - \{T + 2,46 + 1(9,8)(\sin 30^\circ)\} = (1 \times) a$ ✓
 $40 - T - 7,36 = a$
 $32,64 - T = a$ (1)

For 4 kg block / Vir 4 kg blok
 $T - (mg \sin \theta + f_k) = 4a$
 $T - (4 \times 9,8 \sin 30^\circ + 10) = 4a$ ✓
 $T - 29,6 = 4a$ (2)

From (1) and (2) / Vanaf (1) en (2)
 $a = 0,61 \text{ m}\cdot\text{s}^{-2}$
 $T = 29,6 + (4(0,61))$ ✓
 $T = 32,04 \text{ N}$ ✓

(6)

[16]

QUESTION 3

3.1

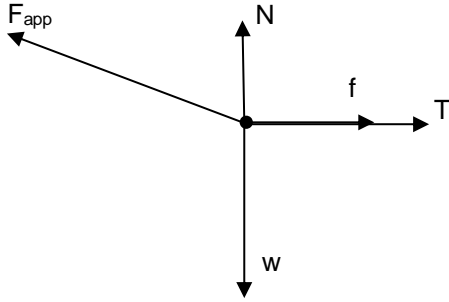

Accepted labels		
w	✓	F _g / F _w / weight / mg / gravitational force
T	✓	F _T / tension
F	✓	F _a / F ₆₀ / 60 N / F _{applied} / F _t /
N	✓	F _N
f	✓	F _f

(5)

3.2.1

$$\left. \begin{aligned} F_{60y} &= F_{60} \sin\theta \\ F_{60y} &= 60 \sin 10^\circ \\ &= 10,42 \text{ N} \end{aligned} \right\} \checkmark \quad \text{OR} \quad \left. \begin{aligned} F_{60Y} &= F_{60} \cos\theta \\ F_{60Y} &= 60 \cos 80^\circ \end{aligned} \right\} \checkmark$$

(2)

3.2.2

$$\left. \begin{aligned} F_{60x} &= F_{60} \cos\theta \\ F_{60x} &= 60 \cos 10^\circ \\ &= 59,09 \text{ N} \end{aligned} \right\} \checkmark \quad \text{OR} \quad \left. \begin{aligned} F_{60x} &= F_{60} \sin\theta \\ F_{60x} &= 60 \sin 80^\circ \end{aligned} \right\} \checkmark$$

(2)

3.3

When a resultant/net force acts on an object, the object will accelerate in the direction of the force at an acceleration directly proportional to the force ✓ and inversely proportional to the mass of the object. ✓

(2)

3.4

<p>POSITIVE MARKING FROM Q3.2.</p> $\left. \begin{aligned} N &= mg - F_{60y} \\ N &= \{5(9,8) - 10,42\} \end{aligned} \right\} \checkmark$ <p>= 38,58 N ✓</p>	OR	$\left. \begin{aligned} F_y + N &= w \\ N &= w - F_y = mg - F_y \\ &= [(5)(9,8) - 10,42] \end{aligned} \right\} \checkmark$ <p>= 38,58 N ✓</p>
--	----	--

(2)

3.5

POSITIVE MARKING FROM QUESTION 3.2.2 AND 3.4.

$$F_{net} = ma \quad \checkmark \quad \text{OR} \quad T - m_2g = m_2a \quad \text{OR} \quad T - 2(9,8) = 2a$$

$$T - 19,6 \quad \checkmark = 2a \dots\dots\dots(1)$$

$$F_{60x} = (f + T) = m_8a$$

$$60 \cos 10^\circ - (f + T) = 5a$$

$$60 \cos 10^\circ - [(\mu_k N) \checkmark + T] = 5a$$

$$59,09 - (0,5 \times 38,58) - T \quad \checkmark = 5a$$

$$39,8 - T = 5a \dots\dots\dots(2)$$

$$a = 2,886 \text{ ms}^{-2}$$

$$T - 19,6 = 2(2,886) \quad \checkmark \quad \therefore T = 25,37 \text{ N} \quad \checkmark$$

OR From equation (2): T = 25,37 N

OR T - 19,6 = 2a(1) x 5

$$59,09 - 19,29 - T = 5a \quad \dots\dots\dots(2) \times 2$$

$$7T - 177,6 = 0 \quad \checkmark \quad \therefore T = 25,37 \text{ N} \quad \checkmark$$

(7)
[20]

QUESTION 4

4.1.1

When body A exerts a force on body B, body B exerts a force of equal magnitude ✓ in the opposite direction ✓ on body A.

(2)

4.1.2

<p>For 2,5 kg block</p> $T = mg \quad \checkmark$ $\therefore T = (2,5)(9,8) \quad \checkmark$ <p>= 24,5 N ✓</p>	OR	$F_{net} = ma$ $T - mg = (2,5)(0) \quad \checkmark$ $T - (2,5)(9,8) \quad \checkmark = 0$ <p>T = 24,5 N ✓</p>	OR	$F_{net} = ma$ $mg - T = (2,5)(0) \quad \checkmark$ $(2,5)(9,8) - T \quad \checkmark = 0$ <p>T = 24,5 N ✓</p>
--	----	---	----	---

(3)

4.1.3

<p>POSITIVE MARKING FROM Q4.1.2.</p> <p>For mass M: $f_s = \mu_s N \quad \checkmark \quad \therefore N = \frac{24,5 \checkmark}{0,2} = 122,5 \text{ N}$</p> $N = Mg = 122,5 \text{ N} \quad \therefore M(9,8) = 122,5 \text{ N} \quad \checkmark$ $\therefore M = 12,5 \text{ kg} \quad \checkmark$	OR	$\mu_s N \quad \checkmark = \mu_s Mg$ $24,5 \checkmark = (0,2) \checkmark M(9,8) \quad \checkmark$ <p>M = 12,5 kg ✓</p>
---	----	---

(5)

4.1.4

<p>For the 5 kg block:</p> $f_k = \mu_k N$ $f_k = (0,15)(5)(9,8) \quad \checkmark = 7,35 \text{ N}$ $F_{net} = ma$ $T - f_k = ma \quad \checkmark \quad \therefore T - 7,35 = 5a \quad \checkmark$	<p>For the 2,5 kg block:</p> $w - T = ma$ $(2,5)(9,8) - T = 2,5a \quad \checkmark \quad \therefore 17,15 = 7,5$ $\therefore a = 2,29 \text{ m} \cdot \text{s}^{-2} \quad \checkmark$
--	--

(5)

4.2

$F = G \frac{m_1 m_2}{r^2} \checkmark$ $F = \frac{(6,67 \times 10^{-11})(6,5 \times 10^{20})(90)}{(550 \times 10^3)^2} = 12,90 \text{ N} \checkmark \quad (12,899 \text{ N})$
<p>OR</p> $g = \frac{Gm}{r^2} \checkmark$ $g = \frac{(6,67 \times 10^{-11})(6,5 \times 10^{20})}{(550 \times 10^3)^2} \checkmark$ $= 0,143 \dots \text{m} \cdot \text{s}^{-2}$ $w = mg$ $= (90)(0,143 \dots) \checkmark = 12,89 \text{ N} \checkmark \text{ (downwards)} \quad (\text{Accept } 12,6 \text{ N} - 12,90 \text{ N})$

(4)
[19]

QUESTION 5

5.1.1 **For the 5 kg mass/Vir die 5 kg massa:**

$T - f = ma$
 $T - \mu_k(mg) = ma \checkmark$
 $T - (0,4)(5)(9,8) \checkmark = 5a \checkmark \dots \dots \dots (1)$

For the 20 kg mass/Vir die 20 kg massa

$mg - T = ma$
 $20(9,8) - T = 20a \checkmark \dots \dots \dots (2)$

$176,4 = 25a \quad (1) + (2)$
 $\therefore a = 7,06 \text{ (7,056) m} \cdot \text{s}^{-2} \checkmark$

(5)

5.1.2 **POSITIVE MARKING FROM QUESTION 5.1.1.**

<p>OPTION 1/OPSIE 1</p> $v_f^2 = v_i^2 + 2a\Delta y \checkmark$ $= 0 \checkmark + (2)(7,056)(6) \checkmark$ $v_f = 9,20 \text{ m} \cdot \text{s}^{-1} \checkmark$	<p>OPTION 2/OPSIE 2</p> <p>The 5 kg mass travels as fast as the 20 kg mass <i>Die 5 kg massa beweeg net so vinnig soos die 20 kg massa</i></p> $W_{\text{net}} = \Delta K \checkmark$ $(5)(7,056)(6 \cos 0^\circ) \checkmark = \frac{1}{2}(5)(v_f^2 - 0) \checkmark$ $v_f = 9,20 \text{ m} \cdot \text{s}^{-1} \checkmark$
--	--

(4)

5.1.3 6 m \checkmark

(1)

5.2.1 Each body in the universe attracts every other body with a force that is directly proportional to the product of their masses \checkmark and inversely proportional to the square of the distance between their centres. \checkmark

(2)

5.2.2 $F = \frac{Gm_1 m_2}{r^2} \checkmark$

On the mountain/Op die berg

$$F_g = \frac{(6,67 \times 10^{-11})(5,98 \times 10^{24})(65)}{(6,38 \times 10^6 + 6 \times 10^3)^2} \checkmark$$

$$= 627,2 \text{ N}$$

On the ground/Op die grond

$F_g = W = mg$
 $= (65 \times 9,8) \checkmark$
 $= 637 \text{ N}$

$F_g = \frac{(6,67 \times 10^{-11})(5,98 \times 10^{24})(65)}{(6,38 \times 10^6)^2}$ $= 636,94 \text{ N}$

Difference/Verskil $= (637 - 627,2) \checkmark$
 $= 9,8 \text{ N} \checkmark$

(6)
[18]

QUESTION 6

6.1 A body will remain in its state of rest or motion at constant velocity ✓ unless a resultant/net force ✓ acts on it. (2)

6.2 0 (N) ✓ /zero (newton) (1)

6.3

2 kg block

OR

10 kg block

Accepted labels

w	$F_g / F_w / \text{weight} / mg / \text{gravitational force}$
T	$F_T / \text{tension}$
15 N	$F_a / F_{15N} / F_{\text{applied}} / F_t / F$

(3)

6.4

2 kg block

$$F_{\text{net}} = ma$$

$$F_a + F_g + (-T) = ma$$

$$F_a + mg + (-T) = ma$$

$$[15 + (2)(9,8) - T] \checkmark = (2)(1,2) \checkmark$$

$$T = 32,2 \text{ N}$$

10 kg block

$$T + (-f_k) = ma$$

$$T - \mu_k N = ma$$

$$T - \mu_k mg = ma$$

$$32,2 - (\mu_k)(10)(9,8) \checkmark = (10)(1,2) \checkmark$$

$$\therefore \mu_k = 0,21 \checkmark$$

(7)

6.5 Smaller than ✓ (1)

6.6 Remains the same ✓ (1)

⊖ The coefficient of kinetic friction is independent of the surface areas in contact. ✓ **OR:** The coefficient of kinetic friction depends only on type of materials used. ✓ (2)

[16]

QUESTION 7

7.1 When a resultant/net force acts on an object, the object will accelerate in the (direction of the net/resultant force). The acceleration is directly proportional to the net force ✓ and inversely proportional to the mass ✓ of the object. (2)

7.2 $f_k = \mu_k N \checkmark = \mu_k mg = (0,15)(3)(9,8) \checkmark = 4,41 \text{ N} \checkmark$ (3)

7.3

Accepted Labels

w	$F_g / F_w / \text{force of earth on block} / \text{weight} / 14,7 \text{ N} / mg / \text{gravitational force}$
N	$F_N / F_{\text{normal}} / \text{normal force}$
T	$\text{Tension} / F_T$
f_k	$f_{\text{kinetic friction}} / f / F_f / \text{kinetic friction}$
25 N	$F_{\text{applied}} / F_A / F$

(5)

7.4

7.4.1

<p>OPTION 1</p> $f_k = \mu_k N = \mu_k(25 \sin 30^\circ + mg)$ $= 0,15[(25 \sin 30^\circ) \checkmark + (1,5)(9,8) \checkmark]$ $= 4,08 \text{ N} \checkmark$	<p>OPTION 2</p> $f_k = \mu_k N = \mu_k(25 \cos 60^\circ + mg)$ $= 0,15[(25 \cos 60^\circ) \checkmark + (1,5)(9,8) \checkmark]$ $= 4,08 \text{ N} \checkmark$
---	---

(3)

7.4.2

POSITIVE MARKING FROM Q7.2 & Q7.4.1.

For the 1,5 kg block

$$F_{\text{net}} = ma$$

$$F_x + (-T) + (-f_k) = ma$$

$$25 \cos 30^\circ - T - f_k = 1,5a$$

$$(25 \cos 30^\circ - T) - 4,08 \checkmark = 1,5a$$

$$17,571 - T = 1,5a \dots\dots\dots(1)$$

For the 3 kg block

$$T - f_k = 3a$$

$$T - 4,41 \checkmark = 3a \dots\dots\dots(2)$$

$$13,161 = 4,5 a \quad \therefore a = 2,925 \text{ m}\cdot\text{s}^{-2} \text{ and } T = 13,19 \text{ N} \checkmark \quad (13,17 \text{ N} - 13,19 \text{ N})$$

✓ either one

(5)

[18]

QUESTION 8

8.1
8.1.1

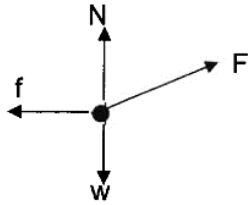

Accepted labels/Aanvaarde benoemings		
w	F_g/F_w /weight/mg/gravitational force F_g/F_w /gewig/mg/gravitasiekrag	✓
f	Friction/ $F_f/f_k/3\text{ N/wrywing}/F_w$	✓
N	Normal (force)/ $F_{\text{normal}}/F_N/F_{\text{normaal}}/F_{\text{reaction/reaksie}}$	✓
F	$F_A/F_{\text{applied/toegepas}}$	✓

(4)

8.1.2 $f_k = \mu_k N$ ✓
 $3 = (0,2)N$ ✓
 $N = 15\text{ N}$ ✓

(3)

8.1.3 **POSITIVE MARKING FROM QUESTION 8.1.2.**

$$\left. \begin{aligned} F_{\text{net}} &= ma \\ N + F_{\text{vert}} - w &= 0 \\ N + F_{\text{vert}} &= w \end{aligned} \right\} \text{✓ Any one}$$

$F \sin 20^\circ = (2)(9,8) - 15$ ✓
 $F = 13,45\text{ N}$ ✓

(4)

8.1.4 **POSITIVE MARKING FROM QUESTION 8.1.3.**

$$\left. \begin{aligned} F_{\text{net}} &= ma \\ F \cos 20^\circ - f &= ma \end{aligned} \right\} \text{✓ Any one}$$

$13,45 \cos 20^\circ - 3 = 2a$ ✓
 $a = 4,82\text{ m}\cdot\text{s}^{-2}$ ✓

(3)

8.2

8.2.1 Each body in the universe attracts every other body with a force that is directly proportional to the product of their masses ✓ and inversely proportional to the square of the distance between their centres. ✓

(2)

8.2.2 Increases ✓

Gravitational force is inversely proportional to the square of the distance between the centres of the objects. ✓ **OR** $F \propto \frac{1}{r^2}$

(2)
[18]

QUESTION 9

9.1 0 N/zero ✓

(1)

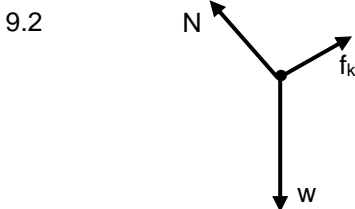

Accepted labels	
w	F_g/F_w /weight/mg/gravitational force/N/19,6 N
f	F_{friction}/F_f /friction/ f_k
N	F_N/F_{normal} /normal force
	Deduct 1 mark for any additional force.
	Mark is given for both arrow and label

(3)

9.3.1 $F_{\text{net}} = ma$
 $f_k - mg \sin \theta = 0$ } ✓ 1 mark for any of these
 $f_k = mg \sin \theta$
 $f_k = (2)(9,8) \sin 7^\circ$ ✓ ∴ $f_k = 2,39\text{ N}$ ✓ (2,389) N

(3)

9.3.2 **POSITIVE MARKING FROM QUESTION 9.3.1.**

$$\left. \begin{aligned} f_k &= \mu_k N \\ &= \mu_k mg \cos 7^\circ \end{aligned} \right\} \text{✓ 1 mark for any of these}$$

$2,389 = \mu_k (2)(9,8) \cos 7^\circ$ ✓ ∴ $\mu_k = 0,12$ ✓

(3)

9.3.3 **POSITIVE MARKING FROM QUESTION 9.3.2.**

OPTION 1
 $F_{\text{net}} = ma$ OR $-f_k = ma$ OR $\mu_k N = ma$ ✓
 $-\mu_k (mg) = ma$
 $-(0,12)(2)(9,8) = 2a$ ✓ ∴ $a = -1,176\text{ m}\cdot\text{s}^{-2}$ (-1,18)
 $v_f^2 = v_i^2 + 2a\Delta x$
 $0 = (1,5)^2 + 2(-1,176)\Delta x$ ✓ ∴ $\Delta x = 0,96\text{ m}$ ∴ Distance = 0,96 m ✓

(5)
[15]

QUESTION 10

10.1.1 An object continues in its state of rest or uniform motion (moving with constant velocity) unless it is acted upon by an unbalanced (resultant/net) force. ✓✓ (2)

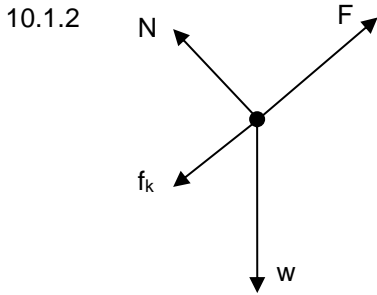

Accepted labels	
w	F _g / F _w /weight/mg /78,4 N/gravitational force
F	F _{app} /F _A / applied force (Accept T / tension)
f _k	(kinetic) friction/F _f /f/F _w
N	F _N /Normal (force)/ 67,9 N

Notes:

- Mark awarded for label and arrow.
- Any other additional force(s): Max. 3/4
- If force(s) do not make contact with body: Max. 3/4

10.1.3

$F_{net} = ma$ $F_{net} = 0$ $F + (-f_k) + (-F_{gll}) = ma$ $F - (f_k + F_{gll}) = ma$ $F - 20,37 - (8)(9,8)\sin 30^\circ = 0$ ✓ ✓ ∴ F = 59,57 N ✓ OR $F - 20,37 - (8)(9,8)\cos 60^\circ = 0$ ✓ ✓ ∴ F = 59,57 N ✓	} ✓ Any one	OR $F - 20,37 - 39,2 = 0$ ✓ $F = 59,57 \text{ N}$ ✓ OR $F = \{20,37 + (8)(9,8)\sin 30^\circ\}$ ✓
--	-------------	--

10.1.4

OPTION 1 $F_{net} = ma$ $(F_{gll} - f_k) = ma$ $(8)(9,8)\sin 30^\circ - 20,37 = 8a$ ✓ ∴ magnitude a = 2,35 m·s ⁻² ✓	OPTION 2 $F_{net} = ma$ $(f_k - F_{gll}) = ma$ $20,37 + [-(8)(9,8)\sin 30^\circ] = 8a$ ✓ ∴ a = -2,35 m·s ⁻² ∴ magnitude a = 2,35 m·s ⁻² ✓
---	---

MOTION OF BLOCK MOVING UP PLANE IMMEDIATELY AFTER FORCE IS REMOVED:

OPTION 1 Downward positive $F_{net} = ma$ $(F_{gll} + f_k) = ma$ $(8)(9,8)\sin 30^\circ + 20,37 = 8a$ ✓ ∴ magnitude a = 7,45 m·s ⁻² ✓	OPTION 2 Upwards positive $F_{net} = ma$ $(F_{gll} + f_k) = ma$ $-(8)(9,8)\sin 30^\circ - 20,37 = 8a$ ✓ ∴ a = -7,45 m·s ⁻² ∴ magnitude a = 7,45 m·s ⁻² ✓
---	---

10.2.1 Each body in the universe attracts every other body with a force that is directly proportional to the product of their masses ✓ and inversely proportional to the square of the distance between their centres. ✓ (2)

10.2.2

OPTION 1 $g = \frac{GM}{r^2}$ ✓ $6 = \frac{(6,67 \times 10^{-11})M}{(700 \times 10^3)^2}$ ✓ $M = 4,41 \times 10^{22} \text{ kg}$ ✓	OPTION 2 $F = G \frac{m_1 m_2}{r^2}$ $mg = \frac{GmM}{r^2}$ } ✓ Any one $(200)(6) = \frac{(6,67 \times 10^{-11})(200)M}{(700 \times 10^3)^2}$ ✓ ∴ M = 4,41 x 10 ²² kg ✓
--	--

[21]

QUESTION 11

11.1 An object continues in its state of rest or uniform motion (moving with constant velocity) unless it is acted upon by a resultant/net force. ✓✓ (2)

11.2

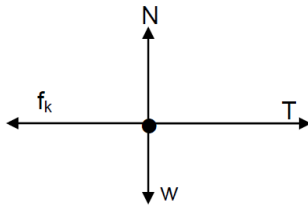

Accepted labels		
w	F _g /F _w /weight/mg/gravitational force	✓
f	Friction/F _f /f _k /27 N	✓
N	Normal (force)/F _{normal} /F _N /F _{reaction}	✓
T	F _T /tension	✓

(4)

11.3

Object Q:	Object P:
$F_{net} = ma$ $F_{net} = 0$ $T + (f_k) = ma$ $T - 3 = 0$ ✓ $T = 3 \text{ N}$	$F_{net} = ma$ $F_{hor} - (f_k + T) = ma$ ✓ $(F \cos 30^\circ) - 5 - 3 = 0$ ✓ $F = 9,24 \text{ N}$ ✓ (9,238 N)

(6)

11.4

3 s ✓

(1)

11.5

Y ✓

Graph Y represents the motion of Q after the string breaks.

Graph Y shows a decreasing velocity ✓ with a negative acceleration. ✓

This is because the net force (friction) acting on Q is in the opposite direction to its motion. ✓

(4)

[17]

QUESTION 12

12.1

The rate of change of velocity. ✓✓

(2)

12.2

$$\Delta y = v_i \Delta t + \frac{1}{2} a \Delta t^2$$

$$0,5 = (0)(3) + \frac{1}{2} (a)(3^2) \quad \checkmark \therefore a = 0,11 \text{ m}\cdot\text{s}^{-2} \checkmark$$

(3)

12.3

POSITIVE MARKING FROM QUESTION 12.2.

For the 3 kg mass:

$$F_{net} = ma \text{ OR } (mg - T) / (mg + T) = ma \quad \checkmark \therefore (3)(9,8) - T = (3)(0,11) \quad \checkmark \therefore T = 29,07 \text{ N} \quad \checkmark$$

(3)

12.4

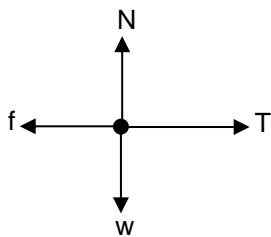

Accepted labels		
w	F _g / F _w / weight / mg / gravitational force	✓
f	Friction / F _f / f _k / 27 N	✓
N	Normal (force) / F _{normal} / F _N / F _{reaction}	✓
T	F _T / tension	✓

(4)

12.5

POSITIVE MARKING FROM QUESTION 12.2 AND QUESTION 12.3.	
For P: $F_{net} = ma$ $T - f = ma$ $29,07 - 27 = m(0,11)$ ✓ $m = 18,82 \text{ kg}$ ✓ (Range: 18,60 – 18,82)	OR For P: $F_{net} = ma$ $T - f = ma$ $29,72 - 27 = m(0,11)$ ✓ $\therefore m = 24,73 \text{ kg}$ ✓

(3)

[15]

QUESTION 13

13.1

When a (non-zero) resultant/net force acts on an object, the object will accelerate in the direction of the force with an acceleration that is directly proportional to the force and inversely proportional to the mass of the object. ✓✓

(2)

13.2

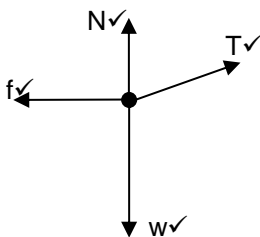

Accepted labels		
N	F _N ; Normal, normal force	✓
f	F _f / f _k / frictional force/kinetic frictional force/	✓
w	F _g ; mg; weight; F _{Earth on block} ; F _w / 78,4 N ✓	✓
T	Tension; F _T /F _A , F / 16,96 N ✓	✓

(4)

13.3.1

The 2/8 kg block /system is accelerating. ✓

(1)

13.3.2

For 2 kg:
 $F_{net} = ma$
 $mg - T = ma$
 $(2)(9,8) - T = 2(1,32)$ ✓ $\therefore T = 16,96 \text{ N}$ ✓

$F_{net} = ma \therefore mg + T = ma$ $(2)(-9,8) + T = 2(-1,32)$ ✓ $\therefore T = 16,96 \text{ N}$ ✓
--

(3)

13.3.3 **POSITIVE MARKING FROM QUESTION 13.3.2.**

$$\left. \begin{aligned} F_{\text{net}} &= ma \\ T \cos 15^\circ - f &= ma \\ T_x &= T \cos 15^\circ \end{aligned} \right\} \checkmark \text{ any one}$$

$$= 16,96 \cos 15^\circ = 16,38 \text{ N (16,382 N)}$$

$$16,382 - f \checkmark = (8)(1,32) \checkmark \therefore f = 5,82 \text{ N (to the left)} \checkmark$$

(4)

13.4 **ANY ONE**

Normal force changes/decreases \checkmark

The angle (between string and horizontal) changes/increases.

The vertical component of the tension changes/increases.

(1)

13.5  Yes \checkmark

The frictional force (coefficient of friction) depends on the nature of the surfaces in contact. \checkmark

(2)

[17]

VERTICAL PROJECTILE MOTION

QUESTION 1

1.1 Motion under the influence of the gravitational force/weight ONLY. $\checkmark \checkmark$

(2)

1.2

<p>OPTION 1 Upwards positive: $\Delta y = v_i \Delta t + \frac{1}{2} a \Delta t^2 \checkmark$ $0 \checkmark = 15 \Delta t + \frac{1}{2} (-9,8) \Delta t^2 \checkmark$ $\Delta t = 3,06 \text{ s} \therefore \text{It takes } 3,06 \text{ s} \checkmark$</p>	<p>Downwards positive: $\Delta y = v_i \Delta t + \frac{1}{2} a \Delta t^2 \checkmark$ $0 \checkmark = -15 \Delta t + \frac{1}{2} (9,8) \Delta t^2 \checkmark$ $\Delta t = 3,06 \text{ s} \therefore \text{It takes } 3,06 \text{ s} \checkmark$</p>
<p>OPTION 2 Upwards positive: $v_f = v_i + a \Delta t \checkmark$ $0 \checkmark = 15 + (-9,8) \Delta t \checkmark$ $\Delta t = 1,53 \text{ s}$ It takes (2)(1,53) = 3,06 s \checkmark</p>	<p>Downwards positive: $v_f = v_i + a \Delta t \checkmark$ $0 \checkmark = -15 + (9,8) \Delta t \checkmark$ $\Delta t = 1,53 \text{ s}$ It takes (2)(1,53) = 3,06 s \checkmark</p>

(4)

1.3 **POSITIVE MARKING FROM QUESTION 1.2.**

<p>Upwards positive: $v_f^2 = v_i^2 + 2a \Delta y \checkmark$ For ball A $0 = (15)^2 \checkmark + 2(-9,8) \Delta y \checkmark \therefore \Delta y_A = 11,48 \text{ m}$ When A is at highest point: $\Delta y_B = v_i \Delta t + \frac{1}{2} a \Delta t^2$ $= 0 + \frac{1}{2} (-9,8) (1,53)^2 \checkmark \checkmark$ $\Delta y_B = -11,47 \text{ m} \therefore \Delta y_B = 11,47 \text{ m downward}$ Distance = $y_A + y_B = 11,47 + 11,48 \checkmark$ $= 22,95 \text{ m} \checkmark$</p>	<p>Downwards positive: $v_f^2 = v_i^2 + 2a \Delta y \checkmark$ For ball A $0 = (-15)^2 \checkmark + 2(9,8) \Delta y \checkmark \therefore \Delta y_A = -11,48 \text{ m}$ When A is at highest point: $\Delta y_B = v_i \Delta t + \frac{1}{2} a \Delta t^2$ $= 0 + \frac{1}{2} (9,8) (1,53)^2 \checkmark \checkmark$ $\Delta y_B = 11,47 \text{ m} \therefore \Delta y_B = 11,47 \text{ m downward}$ Distance = $y_A + y_B = 11,48 + 11,47 \checkmark$ $= 22,95 \text{ m} \checkmark$</p>
---	--

(7)

1.4 **POSITIVE MARKING FROM QUESTION 1.2.**
UPWARD AS POSITIVE

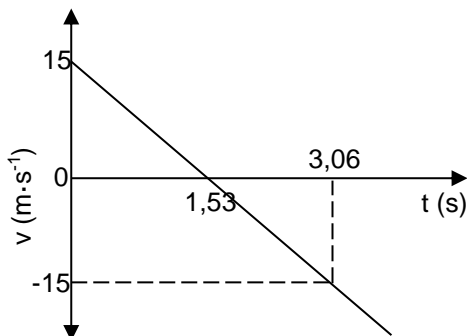

DOWNWARD POSITIVE

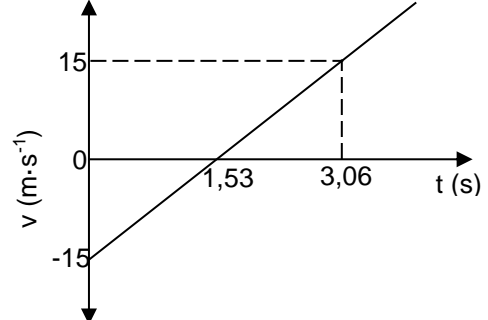

Marking criteria	
Graph starts at correct initial velocity shown.	\checkmark
Time for maximum height shown (1,53 s).	\checkmark
Time for return shown (3,06 s)	\checkmark
Shape: Straight line extending beyond 3,06 s	\checkmark

(4)

[17]

QUESTION 2

2.1 Free fall ✓ (1)

<p>Upward positive: $\Delta y = v_i \Delta t + \frac{1}{2} a \Delta t^2$ $-30 \checkmark = v_i (1,5) + \frac{1}{2} (-9,8)(1,5)^2 \checkmark$ $v_i = 12,65 \text{ m}\cdot\text{s}^{-1} \checkmark$</p>	<p>Downward positive: $\Delta y = v_i \Delta t + \frac{1}{2} a \Delta t^2 \checkmark$ $30 \checkmark = v_i (1,5) + \frac{1}{2} (9,8)(1,5)^2 \checkmark$ $v_i = 12,65 \text{ m}\cdot\text{s}^{-1} \checkmark$</p>
--	---

2.2.2 **POSITIVE MARKING FROM QUESTION 2.2.1.**

Downwards as positive

$v_f^2 = v_i^2 + 2a\Delta y \checkmark$
 $12,65^2 \checkmark = 0 + 2(9,8) \Delta y \checkmark$
 $\Delta y = 8,16 \text{ m} \checkmark$
Height/Hoogte XC = XB + BC
 $(30 + 8,16) = 38,16 \text{ m}$
Height is/Hoogte is 38,16 m ✓

2.3

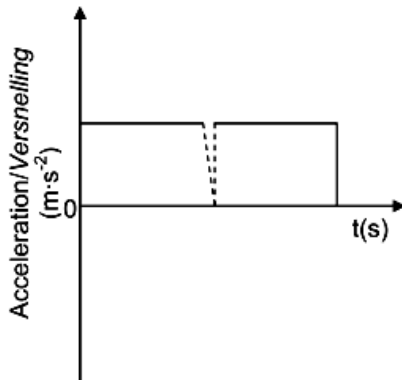

OR

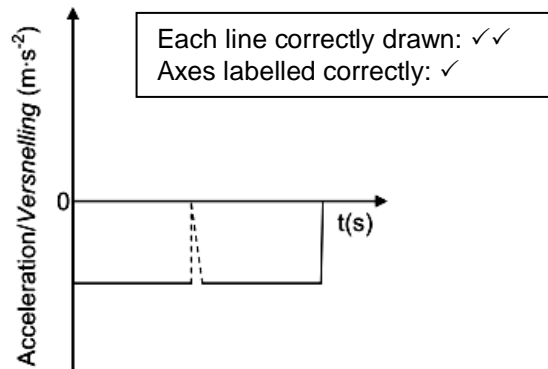

(3)
[13]

QUESTION 3

3.1 5,88 m·s⁻¹ ✓ (1)

3.2 **POSITIVE MARKING FROM Q3.1.**

<p>OPTION 1 $v_f^2 = v_i^2 + 2a\Delta y \checkmark$ $(-19,6)^2 = (5,88)^2 + 2(-9,8) \Delta y \checkmark$ $\Delta y = -17,84 \text{ m}$ <u>Height above ground = 17,84 m</u> ✓</p>	<p>OPTION 2 Area between graph and t-axis for 2,6 s $\Delta y = \frac{1}{2} bh + \frac{1}{2} bh$ $= \frac{1}{2} (0,6)(5,88) \checkmark + \frac{1}{2} (2,6 - 0,6)(-19,6) \checkmark$ $= -17,84 \text{ m} \therefore$ <u>Height above ground = 17,84 m</u> ✓</p>
<p>OPTION 3 By symmetry ball returns to A at 1,2 s downward and $v = -5,88 \text{ m}\cdot\text{s}^{-1}$ $\Delta y =$ Area of trapezium $= \frac{1}{2}(\text{sum of parallel sides})(h) \checkmark$ $= \frac{1}{2}((-5,88) + (-19,6))(2,6 - 1,2) \checkmark$ $= -17,84 \text{ m}$ \therefore <u>Height above ground = 17,84 m</u> ✓</p>	<p>OPTION 4 $\Delta y = \left(\frac{v_i + v_f}{2} \right) \Delta t \checkmark$ $\Delta y = \left(\frac{5,88 + (-19,6)}{2} \right) 2,6 \checkmark = -17,836 \text{ m}$ \therefore <u>Height above ground = 17,84 m</u> ✓</p>

(3)

<p>OPTION 1 $t_p = \left(\frac{3,2 - 2,6}{2} \right) + 2,6 \checkmark$ Time at P (t_p) = 2,9 s ✓</p>	<p>OPTION 2 $v_f = v_i + a\Delta t$ $0 = 2,94 + (-9,8)\Delta t \checkmark$ $\Delta t = 0,3 \text{ s} \therefore t_p = 2,6 + 0,3 = 2,9 \text{ s} \checkmark$</p>
<p>OPTION 3 Gradient = -9,8 $\frac{\Delta y}{\Delta t} = -9,8 \therefore \frac{0 - 2,94}{\Delta t} = -9,8 \checkmark \therefore \Delta t = 0,3 \text{ s}$ Time at P (t_p) = <u>(2,6 + 0,3) = 2,9 s</u> ✓</p>	

(2)

3.4 **POSITIVE MARKING FROM Q3.3.**

<p>OPTION 1 $\Delta y =$ area under graph ✓ $= \frac{1}{2} (0,3)(2,94) \checkmark$ $= 0,44 \text{ m} \checkmark$</p>	<p>OPTION 2 $\Delta y = v_i \Delta t + \frac{1}{2} a \Delta t^2 \checkmark$ $= (2,94)(0,3) + \frac{1}{2} (-9,8)(0,3)^2 \checkmark$ $= 0,44 \text{ m} \checkmark$</p>	<p>OPTION 3 $v_f^2 = v_i^2 + 2a\Delta y \checkmark$ $0 = 2,94^2 + 2(-9,8)\Delta y \checkmark$ $\Delta y = 0,44 \text{ m} \checkmark$</p>
---	---	---

(3)

3.5 **POSITIVE MARKING FROM 3.1, 3.2, 3.3 AND 3.4.**

For $t = 2,9 \text{ s}$ $t_p = 2,9 \text{ s}$
 Distance travelled by balloon since ball was dropped
 $\Delta y = v\Delta t = (5,88)(2,9) \checkmark = 17,05 \text{ m}$
 Height of balloon when ball was dropped = 17,84 m
 Height of balloon after 2,9 s = $(17,05 + 17,84) \checkmark = 34,89 \text{ m}$
 Maximum height of ball above ground = 0,44 m
 \therefore distance between balloon and ball = $(34,89 - 0,44) \checkmark = 34,45 \text{ m} \checkmark$

(4)
[13]

QUESTION 4

<p>4.1 Upwards positive $v_f = v_i + a\Delta t \checkmark$ $-16 \checkmark = 16 - 9,8(\Delta t) \checkmark$ $\Delta t = 3,27 \text{ s} \checkmark$</p>	<p>Downwards positive $v_f = v_i + a\Delta t \checkmark$ $16 \checkmark = -16 + 9,8(\Delta t) \checkmark$ $\Delta t = 3,27 \text{ s} \checkmark$</p>
---	---

(4)

4.2 **POSITIVE MARKING FROM 4.1.**
Upwards positive:

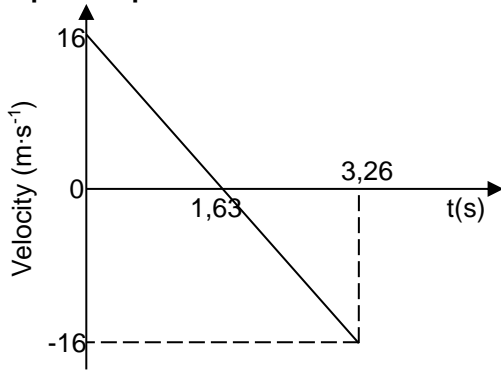

Downwards positive:

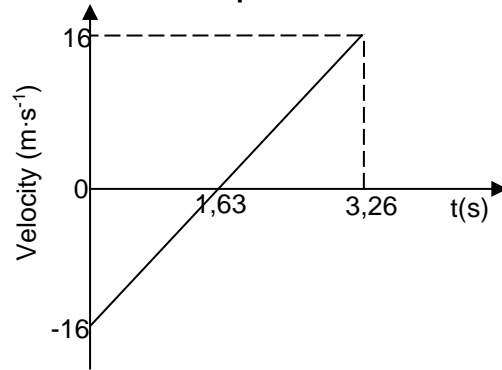

Criteria for graph	
Correct shape for line extending beyond $t = 1,63 \text{ s}$.	✓
Initial velocity correctly indicated as shown.	✓
Time to reach maximum height and time to return to the ground correctly shown.	✓

(3)

4.3 **Marking criteria:**

- Both equations ✓
- Equation for distance/displacement covered by A. ✓
- Equation for distance/displacement covered by B. ✓
- One of equations to have time as $(\Delta t + 1)$ or $(\Delta t - 1)$. ✓
- Solution for $t = 2,24 \text{ s}$. ✓
- Final answer: 11,25 m ✓

<p>Upwards positive: Take y_A as height of ball A from the ground: $\Delta y_A = v_i\Delta t + \frac{1}{2} a\Delta t^2$ $y_A - 0 = 16\Delta t + \frac{1}{2}(-9,8)\Delta t^2 = 16\Delta t - 4,9\Delta t^2 \checkmark$ Take y_B as height of ball B from the ground: $\Delta y_B = v_i\Delta t + \frac{1}{2} a\Delta t^2$ $y_B - 30 = (v_i\Delta t + \frac{1}{2} a\Delta t^2)$ $y_B = 30 - [-9(\Delta t - 1) + \frac{1}{2}(-9,8)(\Delta t - 1)^2] \checkmark$ $= 34,1 + 0,8\Delta t - 4,9 \Delta t^2 \checkmark$ $y_A = y_B$ $\therefore 16\Delta t - 4,9\Delta t^2 = 34,1 + 0,8\Delta t - 4,9\Delta t^2$ $15,2\Delta t = 34,1 \therefore \Delta t = 2,24 \text{ s} \checkmark$ $y_A = 16(2,24) - 4,9(2,24)^2 = 11,25 \text{ m} \checkmark$</p>	<p>Downwards positive: Take y_A as height of ball A from the ground. $\Delta y_A = v_i\Delta t + \frac{1}{2} a\Delta t^2$ $y_A - 0 = -16\Delta t + \frac{1}{2}(9,8)\Delta t^2$ $= -16\Delta t + 4,9\Delta t^2 \checkmark$ Take y_B as height of ball B from the ground. ✓ Both $\Delta y_B = v_i\Delta t + \frac{1}{2} a\Delta t^2$ $y_B - 30 = -(v_i\Delta t + \frac{1}{2} a\Delta t^2)$ $y_B = 30 - [9(\Delta t - 1) + \frac{1}{2}(9,8)(\Delta t - 1)^2] \checkmark$ $= 34,1 + 0,8\Delta t - 4,9 \Delta t^2 \checkmark$ $y_A = y_B \therefore -16\Delta t + 4,9\Delta t^2 = 34,1 + 0,8\Delta t - 4,9\Delta t^2$ $\therefore 15,2\Delta t = 34,1 \therefore \Delta t = 2,24 \text{ s} \checkmark$ $\Delta y_A = (-16(2,24) + 4,9(2,24)^2) = 11,25 \text{ m} \checkmark$</p>
--	--

(6)
[13]

QUESTION 5

5.1.1

<p>OPTION 1/OPSIE 1 Upwards positive/Opwaarts positief: $v_f^2 = v_i^2 + 2a\Delta y$ ✓ $v_f^2 = (-2)^2 + 2(-9,8)(-45)$ ✓ $v_f = 29,76 \text{ m}\cdot\text{s}^{-1}$ ✓</p>	<p>Downwards positive/Afwaarts positief: $v_f^2 = v_i^2 + 2a\Delta y$ ✓ $v_f^2 = (2)^2 + 2(9,8)(45)$ ✓ $v_f = 29,76 \text{ m}\cdot\text{s}^{-1}$ ✓ (29,77 $\text{m}\cdot\text{s}^{-1}$)</p>
<p>OPTION 2/OPSIE 2 Upwards positive/Opwaarts positief: $\Delta y = v_i\Delta t + \frac{1}{2}a\Delta t^2$ ✓ for either equation/vir beide vergelykings $-45 = -2\Delta t + \frac{1}{2}(-9,8)\Delta t^2$ $-4,9 \Delta t^2 - 2\Delta t + 45 = 0$ $4,9 \Delta t^2 + 2\Delta t - 45 = 0$ ✓ $\Delta t = 2,83$</p> <p>$v_f = v_i + a \Delta t$ $v_f = 0 + (-9,8)(2,83)$ $v_f = -29,73 \text{ m s}^{-1}$ ✓</p>	<p>Downwards positive/Afwaarts positief: $\Delta y = v_i\Delta t + \frac{1}{2}a\Delta t^2$ ✓ for either equation/vir beide vergelykings $45 = 2\Delta t + \frac{1}{2}(9,8)\Delta t^2$ $4,9 \Delta t^2 + 2\Delta t - 45 = 0$ ✓ $\Delta t = 2,83$</p> <p>$v_f = v_i + a \Delta t$ ✓ $v_f = 0 + (9,8)(2,83)$ $v_f = 29,73 \text{ m s}^{-1}$ ✓</p>

(4)

5.1.2

<p>POSITIVE MARKING FROM Q5.1.1. OPTION 1/OPSIE 1 Upwards positive/Opwaarts positief: The balls hit the water at the same instant./Die balle tref die water gelyktydig $v_f = v_i + a\Delta t$ ✓ Ball/Bal A $-29,76 = -2 + (-9,8) \Delta t$ $\Delta t = 2,83 \text{ s}$ ✓ \therefore for ball/vir bal B $\Delta t_B = 2,83 - 1 = 1,83 \text{ s}$ \therefore for ball/vir bal B $\Delta t_B = 2,83 - 1 = 1,83 \text{ s}$ ✓</p>	<p>Downwards positive/Afwaarts positief The balls hit the water at the same instant./Die balle tref die water gelyktydig $v_f = v_i + a\Delta t$ ✓ Ball/Bal A $29,76 = 2 + (9,8) \Delta t$ $\Delta t = 2,83 \text{ s}$ ✓ \therefore for ball/vir bal B $\Delta t_B = 2,83 - 1 = 1,83 \text{ s}$ \therefore for ball/vir bal B $\Delta t_B = 2,83 - 1 = 1,83 \text{ s}$ ✓</p>
<p>OPTION 2 Upwards positive/Opwaarts positief: Ball/Bal A $\Delta y = v_i\Delta t + \frac{1}{2}a\Delta t^2$ ✓ $-45 = -2\Delta t + \frac{1}{2}(-9,8)\Delta t^2$ $-4,9 \Delta t^2 - 2\Delta t + 45 = 0$ $4,9 \Delta t^2 + 2\Delta t - 45 = 0$ $\Delta t = 2,83$ ✓ \therefore for ball/vir bal B $\Delta t_B = 2,83 - 1 = 1,83 \text{ s}$ ✓</p>	<p>Downwards positive/Afwaarts positief: $\Delta y = v_i\Delta t + \frac{1}{2}a\Delta t^2$ ✓ $45 = 2\Delta t + \frac{1}{2}(9,8)\Delta t^2$ $4,9 \Delta t^2 + 2\Delta t - 45 = 0$ $\Delta t = 2,83$ ✓ \therefore for ball/vir bal B $\Delta t_B = 2,83 - 1 = 1,83 \text{ s}$ ✓</p>

(4)

5.1.3

<p>POSITIVE MARKING FROM Q5.1.2. Upwards positive/Opwaarts positief: $\Delta t_B = 1,83 \text{ s}$ ✓ $\Delta y = v_i\Delta t + \frac{1}{2}a\Delta t^2$ ✓ $-45 = v_i(1,83) + \frac{1}{2}(-9,8)(1,83)^2$ ✓ $v_i = -15,62 \text{ m}\cdot\text{s}^{-1}$ ✓</p>	<p>Downwards positive: $\Delta t_B = 1,83 \text{ s}$ $\Delta y = v_i\Delta t + \frac{1}{2}a\Delta t^2$ $45 = v_i(1,83) + \frac{1}{2}(9,8)(1,83)^2$ $v_i = 15,62 \text{ m}\cdot\text{s}^{-1}$</p>
--	---

(4)

5.2 **POSITIVE MARKING FROM Q5.1.2 & 5.1.3.**

<u>Upward positive</u>	<u>Downward positive</u>																				
<table border="1" style="width: 100%; border-collapse: collapse;"> <thead> <tr> <th colspan="2">Marking criteria</th> </tr> </thead> <tbody> <tr> <td>One mark for each initial velocity 2 m·s⁻¹ & 15,62 m·s⁻¹</td> <td style="text-align: center;">✓✓</td> </tr> <tr> <td>Release time of ball B: t = 1 s</td> <td style="text-align: center;">✓</td> </tr> <tr> <td>Flight time for both balls indicated as the same on time axis. (2,83 s)</td> <td style="text-align: center;">✓</td> </tr> <tr> <td>Shape – parallel lines</td> <td style="text-align: center;">✓</td> </tr> </tbody> </table>	Marking criteria		One mark for each initial velocity 2 m·s ⁻¹ & 15,62 m·s ⁻¹	✓✓	Release time of ball B: t = 1 s	✓	Flight time for both balls indicated as the same on time axis. (2,83 s)	✓	Shape – parallel lines	✓	<table border="1" style="width: 100%; border-collapse: collapse;"> <thead> <tr> <th colspan="2">Marking criteria</th> </tr> </thead> <tbody> <tr> <td>One mark for each initial velocity - 2 m·s⁻¹ & - 15,62 m·s⁻¹</td> <td style="text-align: center;">✓✓</td> </tr> <tr> <td>Release time of ball B: t = 1 s</td> <td style="text-align: center;">✓</td> </tr> <tr> <td>Flight time for both balls indicated as the same on time axis.</td> <td style="text-align: center;">✓</td> </tr> <tr> <td>Shape – parallel lines</td> <td style="text-align: center;">✓</td> </tr> </tbody> </table>	Marking criteria		One mark for each initial velocity - 2 m·s ⁻¹ & - 15,62 m·s ⁻¹	✓✓	Release time of ball B: t = 1 s	✓	Flight time for both balls indicated as the same on time axis.	✓	Shape – parallel lines	✓
Marking criteria																					
One mark for each initial velocity 2 m·s ⁻¹ & 15,62 m·s ⁻¹	✓✓																				
Release time of ball B: t = 1 s	✓																				
Flight time for both balls indicated as the same on time axis. (2,83 s)	✓																				
Shape – parallel lines	✓																				
Marking criteria																					
One mark for each initial velocity - 2 m·s ⁻¹ & - 15,62 m·s ⁻¹	✓✓																				
Release time of ball B: t = 1 s	✓																				
Flight time for both balls indicated as the same on time axis.	✓																				
Shape – parallel lines	✓																				

(4)
[16]

QUESTION 6

6.1 An object upon which the only force ✓ acting is the force of gravity. ✓ (2)

<p>OPTION 1</p> <p>Upward positive $v_f = v_i + a\Delta t$ ✓ $-30 = 30 + (-9,8)\Delta t$ ✓ $\Delta t = 6,12$ s ✓</p>	<p>Downward positive $v_f = v_i + a\Delta t$ ✓ $30 = -30 + (9,8)\Delta t$ ✓ $\Delta t = 6,12$ s ✓</p>
<p>OPTION 2</p> <p>Upward positive $v_f = v_i + a\Delta t$ ✓ $0 = 30 + (-9,8)\Delta t$ ✓ $\Delta t = 3,06$ s Total time = (2)(3,06) = 6,12 s ✓</p>	<p>Downward positive $v_f = v_i + a\Delta t$ ✓ $0 = -30 + (9,8)\Delta t$ ✓ $\Delta t = 3,06$ s Total time = (2)(3,06) = 6,12 s ✓</p>

(4)

6.3 **POSITIVE MARKING FROM QUESTION 6.2.**

<p>Upward positive</p> $\Delta y = v_i\Delta t + \frac{1}{2}a\Delta t^2$ $\Delta y_{last} = \Delta y_{(6,12)} - \Delta y_{(5,12)}$ $= \{30(6,12) + \frac{1}{2}(-9,8)(6,12)^2\} - \{30(5,12) + \frac{1}{2}(-9,8)(5,12)^2\}$ $= -25,076$ <p>Distance = $\Delta y = 25,08$ m ✓</p>	<p>Downward positive</p> $\Delta y = v_i\Delta t + \frac{1}{2}a\Delta t^2$ $\Delta y_{last} = \Delta y_{(6,12)} - \Delta y_{(5,12)}$ $= \{-30(6,12) + \frac{1}{2}(9,8)(6,12)^2\} - \{-30(5,12) + \frac{1}{2}(9,8)(5,12)^2\}$ $= 25,076$ <p>Distance = $\Delta y = 25,08$ m ✓</p>
---	--

(4)

6.4 **POSITIVE MARKING FROM QUESTION 6.2.**

<p>Upward positive</p> $\Delta y = v_i\Delta t + \frac{1}{2}a\Delta t^2$ $-50 = [v_i(4,12)] + [\frac{1}{2}(-9,8)(4,12)^2]$ $v_i = 8,05 \text{ m}\cdot\text{s}^{-1}$ <p>speed = 8,05 m·s⁻¹ ✓</p>	<p>Downward positive</p> $\Delta y = v_i\Delta t + \frac{1}{2}a\Delta t^2$ $50 = v_i(4,12) + [\frac{1}{2}(9,8)(4,12)^2]$ $v_i = -8,05 \text{ m}\cdot\text{s}^{-1}$ <p>speed = 8,05 m·s⁻¹ ✓</p>
---	--

(4)

6.5

POSITIVE MARKING FROM QUESTIONS 6.2 AND 6.3.

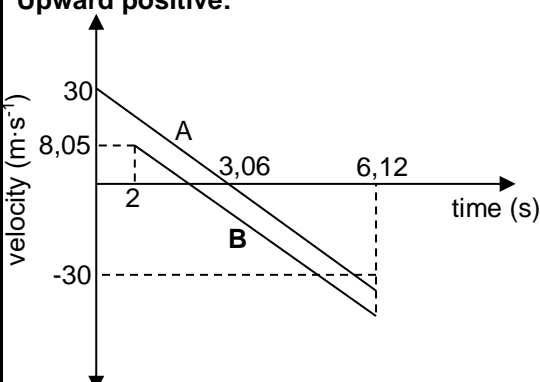
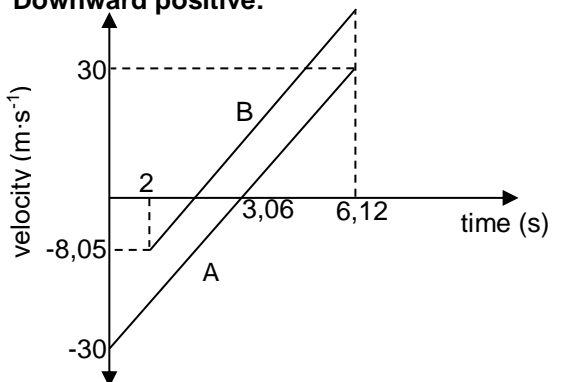
<p>Upward positive:</p>  <table border="1" style="width: 100%; border-collapse: collapse; margin-top: 10px;"> <thead> <tr> <th colspan="2">Marking criteria</th> </tr> </thead> <tbody> <tr> <td>Correct shape of A.</td> <td style="text-align: center;">✓</td> </tr> <tr> <td>Correct shape of Graph B parallel to A below A.</td> <td style="text-align: center;">✓</td> </tr> <tr> <td>Time at which both A and B reach the ground (6,12 s).</td> <td style="text-align: center;">✓</td> </tr> <tr> <td>Time for A to reach the maximum height (3,06 s) shown.</td> <td style="text-align: center;">✓</td> </tr> </tbody> </table>	Marking criteria		Correct shape of A.	✓	Correct shape of Graph B parallel to A below A.	✓	Time at which both A and B reach the ground (6,12 s).	✓	Time for A to reach the maximum height (3,06 s) shown.	✓	<p>Downward positive:</p>  <table border="1" style="width: 100%; border-collapse: collapse; margin-top: 10px;"> <thead> <tr> <th colspan="2">Marking criteria</th> </tr> </thead> <tbody> <tr> <td>Correct shape of A.</td> <td style="text-align: center;">✓</td> </tr> <tr> <td>Correct shape of Graph B parallel to A above A.</td> <td style="text-align: center;">✓</td> </tr> <tr> <td>Time at which both A and B reach the ground (6,12 s).</td> <td style="text-align: center;">✓</td> </tr> <tr> <td>Time for A to reach the maximum height (3,06 s) shown.</td> <td style="text-align: center;">✓</td> </tr> </tbody> </table>	Marking criteria		Correct shape of A.	✓	Correct shape of Graph B parallel to A above A.	✓	Time at which both A and B reach the ground (6,12 s).	✓	Time for A to reach the maximum height (3,06 s) shown.	✓
Marking criteria																					
Correct shape of A.	✓																				
Correct shape of Graph B parallel to A below A.	✓																				
Time at which both A and B reach the ground (6,12 s).	✓																				
Time for A to reach the maximum height (3,06 s) shown.	✓																				
Marking criteria																					
Correct shape of A.	✓																				
Correct shape of Graph B parallel to A above A.	✓																				
Time at which both A and B reach the ground (6,12 s).	✓																				
Time for A to reach the maximum height (3,06 s) shown.	✓																				

(4)
[18]

QUESTION 7

7.1 The motion of an object under the influence of weight/ gravitational force only / Motion in which the only force acting is the gravitational force. ✓✓ (2)

<p>OPTION 1: Upwards positive $v_f^2 = v_i^2 + 2a\Delta y$ ✓ $= 0^2 + (2)(-9,8) \checkmark (-20) \checkmark$ $v_f = 19,80 \text{ m}\cdot\text{s}^{-1} \checkmark$</p>	<p>OPTION 1: Downwards positive $v_f^2 = v_i^2 + 2a\Delta y$ ✓ $= 0^2 + (2)(9,8) \checkmark (20) \checkmark$ $v_f = 19,80 \text{ m}\cdot\text{s}^{-1} \checkmark$</p>
<p>OPTION 2: Upwards positive $\Delta y = v_i\Delta t + \frac{1}{2} a\Delta t^2$ $-20 = 0 + \frac{1}{2} (-9,8) \Delta t^2 \checkmark$ $\Delta t = 2,02 \text{ s}$ $v_f = v_i + a\Delta t$ $= 0 + (-9,8)(2,02) \checkmark$ $= -19,80 \text{ m}\cdot\text{s}^{-1} \therefore v_f = 19,80 \text{ m}\cdot\text{s}^{-1} \checkmark$</p>	<p>OPTION 2: Downwards positive $\Delta y = v_i\Delta t + \frac{1}{2} a\Delta t^2$ $20 = 0 + \frac{1}{2} (9,8) \Delta t^2 \checkmark$ $\Delta t = 2,02 \text{ s}$ $v_f = v_i + a\Delta t$ $= 0 + (9,8)(2,02) \checkmark$ $= 19,80 \text{ m}\cdot\text{s}^{-1} \checkmark$</p>

(4)

7.3 **POSITIVE MARKING FROM QUESTION 7.2.**

<p>OPTION 1: Upwards positive $v_f = v_i + a\Delta t$ ✓ $-19,80 = 0 + (-9,8)\Delta t \checkmark \therefore \Delta t = 2,02 \text{ s} \checkmark$</p>	<p>OPTION 1: Downwards positive $v_f = v_i + a\Delta t$ ✓ $19,80 = 0 + (9,8)\Delta t \checkmark \therefore \Delta t = 2,02 \text{ s} \checkmark$</p>
<p>OPTION 2: Upwards positive: $\Delta y = v_i\Delta t + \frac{1}{2} a\Delta t^2 \checkmark$ $-20 = 0 + \frac{1}{2} (-9,8) \Delta t^2 \checkmark \therefore \Delta t = 2,02 \text{ s} \checkmark$</p>	<p>OPTION 2: Downwards positive: $\Delta y = v_i\Delta t + \frac{1}{2} a\Delta t^2 \checkmark$ $20 = 0 + \frac{1}{2} (9,8) \Delta t^2 \checkmark \therefore \Delta t = 2,02 \text{ s} \checkmark$</p>

(3)

7.4

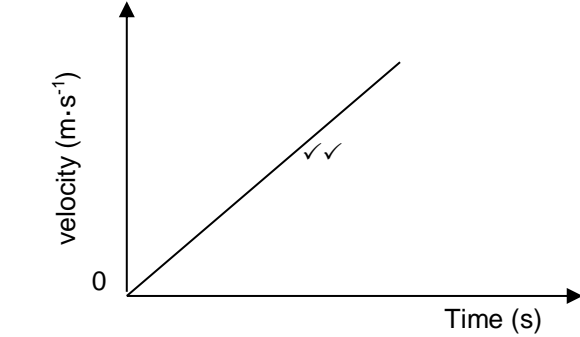
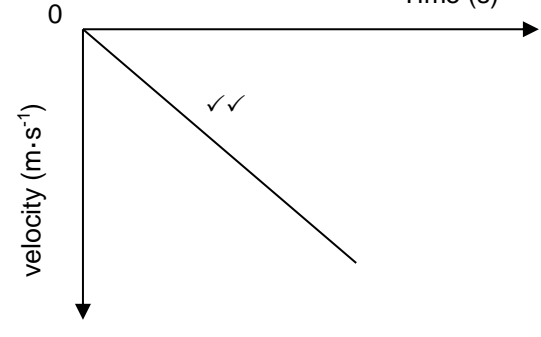
<p>Downward positive</p> 	<p>Upward positive</p> 				
<table border="1" style="width: 100%; border-collapse: collapse;"> <tr> <td style="width: 10%; text-align: center;">✓✓</td> <td style="padding: 2px;">Straight line through the origin.</td> </tr> <tr> <td style="width: 10%;"></td> <td style="padding: 2px;">Deduct 1 mark if axes are not labelled correctly.</td> </tr> </table>		✓✓	Straight line through the origin.		Deduct 1 mark if axes are not labelled correctly.
✓✓	Straight line through the origin.				
	Deduct 1 mark if axes are not labelled correctly.				

(2)
[11]

QUESTION 8

8.1 The only force acting on the ball is the gravitational force. ✓✓ (2)

8.2.1	<p>OPTION 1</p> <p>Upwards as positive $\Delta y = v_i \Delta t + \frac{1}{2} a \Delta t^2 \checkmark$ $= (10)(3) + \frac{1}{2}(-9,8)(3^2) \checkmark = -14,10$ Height of building = 14,10 m ✓</p>	<p>Downwards as positive $\Delta y = v_i \Delta t + \frac{1}{2} a \Delta t^2 \checkmark$ $= (-10)(3) + \frac{1}{2}(9,8)(3^2) \checkmark = 14,10$ Height of building = 14,10 m ✓</p>
	<p>OPTION 2</p> <p>Upward as positive For maximum height: $v_f = v_i + a \Delta t$ $0 = 10 + (-9,8) \Delta t \therefore \Delta t = 1,02 \text{ s}$ Time taken from point A to ground: $3 - 2(1,02) = 0,96 \text{ s}$ $\Delta y = v_i \Delta t + \frac{1}{2} a \Delta t^2 \checkmark$ $= (-10)(0,96) + \frac{1}{2}(-9,8)(0,96)^2 \checkmark$ $= -14,1184 \therefore \text{Height} = 14,12 \text{ m} \checkmark$</p>	<p>Downwards as positive For maximum height: $v_f = v_i + a \Delta t$ $0 = -10 + (9,8) \Delta t \therefore \Delta t = 1,02 \text{ s}$ Time taken from point A to ground: $3 - 2(1,02) = 0,96 \text{ s}$ $\Delta y = v_i \Delta t + \frac{1}{2} a \Delta t^2 \checkmark$ $= (10)(0,96) + \frac{1}{2}(9,8)(0,96)^2 \checkmark$ $= 14,1184 \therefore \text{Height} = 14,12 \text{ m} \checkmark$</p>

(3)

8.2.2 **POSITIVE MARKING FROM QUESTION 8.2.1.**

<p>Upwards as positive: $v_f = v_i + a \Delta t \checkmark = (10) + (-9,8)(3) \checkmark = -19,41$ Speed = 19,41 m·s⁻¹ ✓</p>	<p>Downwards as positive: $v_f = v_i + a \Delta t \checkmark = (-10) + (9,8)(3) \checkmark = 19,41$ Speed = 19,41 m·s⁻¹ ✓</p>
---	--

(3)

8.2.3	<p>Upwards as positive: $v_f^2 = v_i^2 + 2a \Delta y \checkmark$ $0 = v_i^2 + (2)(-9,8)(8) \checkmark \therefore v_i = 12,52 \text{ m·s}^{-1}$ Speed = 12,52 m·s⁻¹ ✓</p>	<p>Downwards as positive: $v_f^2 = v_i^2 + 2a \Delta y \checkmark$ $0 = v_i^2 + (2)(9,8)(-8) \therefore v_i = -12,52$ Speed = 12,52 m·s⁻¹ ✓</p>
-------	---	--

(3)

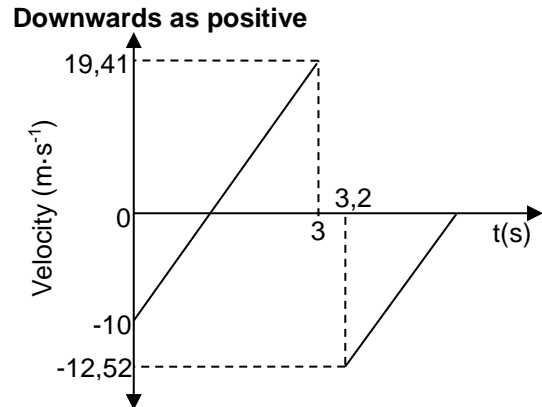
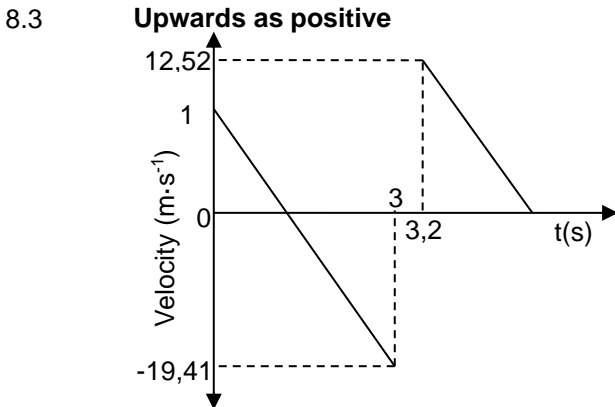

Marking criteria	
Two parallel lines correctly drawn.	✓✓
Mark for velocity calculated in Q8.2.2.	✓
Mark for velocity calculated in Q8.2.3.	✓
Times 3 s and 3,2 s correctly shown.	✓

(4)
[15]

QUESTION 9

9.1 (Motion of) an object in which the only force acting is the gravitational force. ✓✓ (2)

9.2 No ✓ The balloon is not accelerating./The balloon is moving with constant velocity./The net force acting on the balloon is zero. ✓ (2)

9.3	<p>OPTION 1 Upward positive: $\Delta y = v_i \Delta t + \frac{1}{2} a \Delta t^2 \checkmark$ $-22 \checkmark = (-1,2) \Delta t + \frac{1}{2}(-9,8) \Delta t^2 \checkmark \therefore \Delta t = 2 \text{ s} \checkmark$</p>	<p>Downward positive: $\Delta y = v_i \Delta t + \frac{1}{2} a \Delta t^2 \checkmark$ $22 \checkmark = (1,2) \Delta t + \frac{1}{2}(9,8) \Delta t^2 \checkmark \therefore \Delta t = 2 \text{ s} \checkmark$</p>
	<p>OPTION 2</p> <p>Upward positive: $v_f^2 = v_i^2 + 2a \Delta y$ $v_f^2 = (-1,2)^2 + (2)(-9,8)(-22) \checkmark$ ✓Both $v_f = -20,8 \text{ m·s}^{-1}$ $v_f = v_i + a \Delta t$ $-20,8 = -1,2 + -9,8 \Delta t \checkmark \therefore \Delta t = 2 \text{ s} \checkmark$</p>	<p>Downward positive: $v_f^2 = v_i^2 + 2a \Delta y$ $v_f^2 = (1,2)^2 + (2)(9,8)(22) \checkmark$ ✓Both $v_f = 20,8 \text{ m·s}^{-1}$ $v_f = v_i + a \Delta t$ $20,8 = 1,2 + 9,8 \Delta t \checkmark \therefore \Delta t = 2 \text{ s} \checkmark$</p>

(4)

9.4 **POSITIVE MARKING FROM QUESTION 9.3.**

<p>Upward positive: $v_f = v_i + a\Delta t \checkmark \therefore 0 = 15 + (-9,8)\Delta t \checkmark$ $\therefore \Delta t = 1,53 \text{ s}$ Total time elapsed = $\underline{2 + 1,53 + 0,3} \checkmark$ $= 3,83 \text{ s}$ Displacement of the balloon: $\Delta y = v_i\Delta t + \frac{1}{2} a\Delta t^2 = -(1,2)(3,83) \checkmark = -4,6 \text{ m}$ Height = $\underline{22 - 4,6} \checkmark = 17,4 \text{ m} \checkmark$ OR $y_f = y_i + \Delta y = [22 - (1,2)(3,83)] \checkmark \checkmark = 17,4 \text{ m}$ $\therefore \text{Height} = 17,4 \text{ m} \checkmark$</p>	<p>Downward Positive: $v_f = v_i + a\Delta t \checkmark \therefore 0 = -15 + (9,8)\Delta t \checkmark$ $\therefore \Delta t = 1,53 \text{ s}$ Total time elapsed = $\underline{2 + 1,53 + 0,3} \checkmark$ $= 3,83 \text{ s}$ Displacement of the balloon: $\Delta y = v_i\Delta t + \frac{1}{2} a\Delta t^2 = (1,2)(3,83) \checkmark = 4,6 \text{ m}$ Height = $\underline{22 - 4,6} \checkmark = 17,4 \text{ m} \checkmark$ OR $y_f = y_i + \Delta y = [-22 + (1,2)(3,83)] \checkmark \checkmark = -17,4 \text{ m}$ $\therefore \text{Height} = 17,4 \text{ m} \checkmark$</p>
--	--

(6)
[14]**QUESTION 10**

<p>10.1 OPTION 1 Upwards positive: $v_f = v_i + a\Delta t \checkmark \therefore 0 = (12) + (-9,8)(\Delta t) \checkmark$ $\therefore \Delta t = 1,22 \text{ s} \checkmark$</p>	<p>Downwards positive: $v_f = v_i + a\Delta t \checkmark \therefore 0 = (-12) + (9,8)(\Delta t) \checkmark$ $\therefore \Delta t = 1,22 \text{ s} \checkmark$</p>
<p>OPTION 2 Upwards positive: $v_f^2 = v_i^2 + 2a\Delta y$ $0 = 12^2 + 2(-9,8)\Delta y \checkmark \therefore \Delta y = 7,35$ $\Delta y = v_i\Delta t + \frac{1}{2} a\Delta t^2 \checkmark$ $7,35 = 12\Delta t + \frac{1}{2} (-9,8)\Delta t^2 \therefore \Delta t = 1,22 \text{ s} \checkmark$</p>	<p>Downwards positive: $v_f^2 = v_i^2 + 2a\Delta y$ $0 = (-12)^2 + 2(9,8)\Delta y \checkmark \therefore \Delta y = -7,35$ $\Delta y = v_i\Delta t + \frac{1}{2} a\Delta t^2 \checkmark$ $-7,35 = -12\Delta t + \frac{1}{2} (9,8) \Delta t^2 \therefore \Delta t = 1,22 \text{ s} \checkmark$</p>

(3)

10.2 **POSITIVE MARKING FROM QUESTION 10.1.**

<p>OPTION 1 Upwards positive: $v_f = v_i + a\Delta t \checkmark \therefore -3v = -v \checkmark + \underline{(-9,8)(1,22)} \checkmark$ $v = 5,98 \text{ m}\cdot\text{s}^{-1} \checkmark \quad (5,978 \text{ to } 6,03 \text{ m}\cdot\text{s}^{-1})$</p>	<p>Downwards positive: $v_f = v_i + a\Delta t \checkmark \therefore 3v = v \checkmark + \underline{(9,8)(1,22)} \checkmark$ $v = 5,98 \text{ m}\cdot\text{s}^{-1} \checkmark \quad (5,978 \text{ to } 6,03 \text{ m}\cdot\text{s}^{-1})$</p>
<p>OPTION 2 Upwards positive: $F_{\text{net}}\Delta t = m(v_f - v_i) \checkmark$ $mg\Delta t = m(v_f - v_i)$ $(-9,8)(1,2245) \checkmark = \underline{-3v - (-v)} \checkmark$ $v = 6,00 \text{ m}\cdot\text{s}^{-1} \checkmark$</p>	<p>Downwards positive: $F_{\text{net}}\Delta t = m(v_f - v_i) \checkmark$ $mg\Delta t = m(v_f - v_i)$ $(9,8)(1,2245) \checkmark = 3v - v \checkmark$ $v = 6,00 \text{ m}\cdot\text{s}^{-1} \checkmark$</p>

(4)

10.3 **POSITIVE MARKING FROM 10.1 and 10.2.**

<p>OPTION 1 Upwards positive: $\Delta y = v_i\Delta t + \frac{1}{2} a\Delta t^2 \checkmark$ $= \underline{(-5,98)(2,44) + \frac{1}{2}(-9,8)(2,44)^2} \checkmark$ $= -43,764$ $\therefore h = 43,76 \text{ m} \checkmark \quad (43,764 \text{ to } 44,08 \text{ m})$</p>	<p>Downwards positive: $\Delta y = v_i\Delta t + \frac{1}{2} a\Delta t^2 \checkmark$ $= \underline{(5,98)(2,44) + \frac{1}{2}(9,8)(2,44)^2} \checkmark$ $= 43,764$ $\therefore h = 43,76 \text{ m} \checkmark \quad (43,764 \text{ to } 44,08)$</p>
<p>OPTION 2 Upwards positive: $v_f = v_i + a\Delta t$ $v_f = -5,98 + (-9,8)(2,44) = -29,892 \text{ m}\cdot\text{s}^{-1}$ $v_f^2 = v_i^2 + 2a\Delta y \checkmark$ $(-29,892)^2 = (-5,98)^2 + 2(-9,8)\Delta y \checkmark$ $\Delta y = -43,763 \text{ m}$ $\therefore h = 43,76 \text{ m} \checkmark \quad (43,764 \text{ to } 44,08)$</p>	<p>Downwards positive: $v_f = v_i + a\Delta t$ $v_f = 5,98 + 9,8(2,44) = 29,892 \text{ m}\cdot\text{s}^{-1}$ $v_f^2 = v_i^2 + 2a\Delta y \checkmark$ $(29,892)^2 = (5,98)^2 + 2(9,8)\Delta y \checkmark$ $\Delta y = 43,76 \text{ m}$ $\therefore h = 43,76 \text{ m} \checkmark \quad (43,764 \text{ to } 44,08)$</p>
<p>OPTION 3 Upwards positive: For A: $v_f = v_i + a\Delta t$ $-12 = 12 + (-9,8)\Delta t \therefore \Delta t = 2,45 \text{ s}$ For B: $\Delta x = v_i\Delta t + \frac{1}{2} a\Delta t^2 \checkmark$ $= \underline{(-5,98)(2,45) + \frac{1}{2}(-9,8)(2,45)^2} \checkmark$ $= -44,06 \text{ m} \therefore h = 44,06 \text{ m} \checkmark$</p>	<p>Downwards positive: For A: $v_f = v_i + a\Delta t \therefore 12 = -12 + (9,8)\Delta t$ $\therefore \Delta t = 2,45 \text{ s}$ For B: $\Delta x = v_i\Delta t + \frac{1}{2} a\Delta t^2 \checkmark$ $= \underline{(5,98)(2,45) + \frac{1}{2}(9,8)(2,45)^2} \checkmark$ $= 44,06 \text{ m} \therefore h = 44,06 \text{ m} \checkmark$</p>

(3)

10.4 **POSITIVE MARKING FROM QUESTION 10.1 AND QUESTION 10.2.**
Upwards as positive **Downwards as positive**

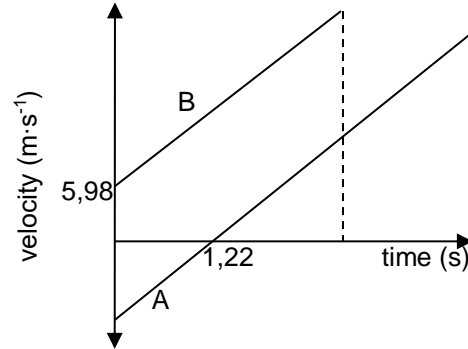
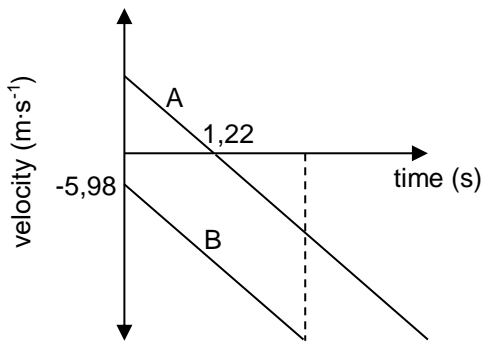

Criteria for graph	
Time 1,22 s shown correctly	✓
Initial velocity for stone B at time t = 0 correctly shown with correct signs	✓
Two sloping parallel lines with A crossing the time axis	✓
Straight line graph for A parallel to graph B, extending beyond the time when B hits the ground	✓

(4)
[14]

QUESTION 11

11.1 10 m·s⁻¹ ✓

(1)

11.2 The gradient represents the acceleration due to gravity (g) ✓ which is constant for free fall. ✓

(2)

<p>11.3 OPTION 1 $\Delta y = v_i \Delta t + \frac{1}{2} a \Delta t^2$ ✓ $= (10)(2) + \frac{1}{2} (9,8)(2^2)$ ✓ $= 39,6 \text{ m}$ Height/Hoogte = 39,6 m ✓</p>	<p>$\Delta y = v_i \Delta t + \frac{1}{2} a \Delta t^2$ ✓ $= (-10)(2) + \frac{1}{2} (-9,8)(2^2)$ ✓ $= -39,6 \text{ m}$ Height/Hoogte = 39,6 m ✓</p>
<p>OPTION 2/OPSIE 2 $\Delta x = \frac{(v_i + v_f)}{2} \Delta t$ ✓ $\Delta x = \left(\frac{10 + 29,6}{2}\right)(2)$ ✓ $\Delta x = 39,6 \text{ m}$ ✓</p>	<p>OPTION 3/OPSIE 3 $v_f^2 = v_i^2 + 2a\Delta x$ ✓ $(29,6)^2 = (10)^2 + 2(9,8)a\Delta x$ ✓ $\Delta x = 39,6 \text{ m}$ ✓</p>

(3)

<p>11.4 OPTION 1 $v_f = v_i + a\Delta t$ ✓ $0 = -25 + (9,8)(\Delta t)$ ✓ $\Delta t = 2,55 \text{ s}$ Total time T/Totale tyd = 8 + 2,55 ✓ $= 10,55 \text{ s}$ ✓</p>	<p>OPTION 2 $v_f = v_i + a\Delta t$ ✓ $0 = 25 + (-9,8)(\Delta t)$ ✓ $\Delta t = 2,55 \text{ s}$ Total time T/Totale tyd = 8 + 2,55 ✓ $= 10,55 \text{ s}$ ✓</p>
---	--

(4)

11.5.1 0,2 s ✓

(1)

11.5.2 4,955 s ✓✓

(2)

11.5.3 -27 m·s⁻¹ ✓

(1)

11.6 Inelastic ✓ The speeds at which it strikes and leaves the ground are not the same/The kinetic energies will not be the same. ✓

(2)
[16]

QUESTION 12

12.1 Motion under the influence of gravity/weight/gravitational force only.

(2)

<p>12.2 OPTION 1 UPWARDS AS POSITIVE $\Delta y = v_i \Delta t + \frac{1}{2} a \Delta t^2$ ✓ = $\frac{(0)(1) + \frac{1}{2} (-9,8)(1^2)}$ ✓ $= -4,9 \text{ m}$ Height = 2Δy = (2)(4,9) $= 9,8 \text{ m}$ ✓</p>	<p>DOWNWARDS AS POSITIVE $\Delta y = v_i \Delta t + \frac{1}{2} a \Delta t^2$ ✓ = $\frac{(0)(1) + \frac{1}{2} (9,8)(1^2)}$ ✓ $= 4,9 \text{ m}$ Height = 2Δy = (2)(4,9) $= 9,8 \text{ m}$ ✓</p>
---	---

<p>OPTION 2 UPWARD POSITIVE $v_f = v_i + a\Delta t = 0 + (-9,8)(1) = -9,8 \text{ m}\cdot\text{s}^{-1}$ $v_f^2 = v_i^2 + 2a\Delta y$ $(-9,8)^2 = 0 + (2)(-9,8)\Delta y$ ✓ $\Delta y = -4,9 \text{ m}$ Height/hoopte = $2\Delta y = (2)(4,9) = 9,8 \text{ m}$ ✓</p>	<p>DOWNWARD POSITIVE $v_f = v_i + a\Delta t = 0 + (9,8)(1) = 9,8 \text{ m}\cdot\text{s}^{-1}$ $v_f^2 = v_i^2 + 2a\Delta y$ $(9,8)^2 = 0 + (2)(9,8)\Delta y$ ✓ $\Delta y = 4,9 \text{ m}$ Height/hoopte = $2\Delta y = (2)(4,9) = 9,8 \text{ m}$ ✓</p>
--	--

(3)

<p>12.3 UPWARDS AS POSITIVE $v_f^2 = v_i^2 + 2a\Delta y$ $= 0 + (2)(-9,8)(-9,8)$ ✓ $v_f = 13,86 \text{ m}\cdot\text{s}^{-1}$ ✓</p>	<p>DOWNWARDS AS POSITIVE $v_f^2 = v_i^2 + 2a\Delta y$ $= 0 + (2)(9,8)(9,8)$ ✓ $v_f = 13,86 \text{ m}\cdot\text{s}^{-1}$ ✓</p>
<p>OR FROM POINT B UPWARDS AS POSITIVE $v_f^2 = v_i^2 + 2a\Delta y$ $= (-9,8)^2 + (2)(-9,8)(-4,9)$ ✓ $v_f = -13,86 \text{ m}\cdot\text{s}^{-1}$ Magnitude = $13,86 \text{ m}\cdot\text{s}^{-1}$ ✓</p>	<p>OR FROM POINT B DOWNWARDS AS POSITIVE $v_f^2 = v_i^2 + 2a\Delta y$ $= (9,8)^2 + (2)(9,8)(4,9)$ ✓ $v_f = 13,86 \text{ m}\cdot\text{s}^{-1}$ ✓</p>

(3)

<p>12.4 POSITIVE MARKING FROM 12.3. UPWARDS AS POSITIVE $v_f^2 = v_i^2 + 2a\Delta y$ $0 = v_f^2 + (2)(-9,8)(4,9)$ ✓ $\therefore v_i = 9,8 \text{ m}\cdot\text{s}^{-1}$</p> <p>$F_{\text{net}}\Delta t = m\Delta v$ $F_{\text{net}}\Delta t = m(v_f - v_i)$ } ✓ 1 mark for any $F_{\text{net}}(0,2)$ ✓ = $0,4[9,8 - (-13,86)]$ ✓ $F_{\text{net}} = 47,32 \text{ N}$ ✓</p>	<p>DOWNWARDS AS POSITIVE $v_f^2 = v_i^2 + 2a\Delta y$ $0 = v_f^2 + (2)(9,8)(-4,9)$ ✓ $\therefore v_i = -9,8 \text{ m}\cdot\text{s}^{-1}$</p> <p>$F_{\text{net}}\Delta t = m\Delta v$ $F_{\text{net}}\Delta t = m(v_f - v_i)$ } ✓ 1 mark for any $F_{\text{net}}(0,2)$ ✓ = $0,4[-9,8 - (13,86)]$ ✓ $F_{\text{net}} = -47,32 \text{ N} \therefore F_{\text{net}} = 47,32 \text{ N}$ ✓</p>
--	---

(6)

[14]

QUESTION 13

13.1 Downwards ✓
 The only force acting on the object is the gravitational force/weight which acts downwards. ✓

(2)

<p>13.2 OPTION 1/ Upward positive $v_f = v_i + a\Delta t$ ✓ $0 = 7,5 + (-9,8)\Delta t$ ✓ $\Delta t = 0,77 \text{ s}$ ✓</p>	<p>Downward positive $v_f = v_i + a\Delta t$ ✓ $0 = -7,5 + (9,8)\Delta t$ ✓ $\Delta t = 0,77 \text{ s}$ ✓</p>
<p>OPTION 2 Upward positive $F_{\text{net}}\Delta t = m(v_f - v_i)$ ✓ $mg\Delta t = m(v_f - v_i)$ $(-9,8)\Delta t = 0 - 7,5$ ✓ $\therefore \Delta t = 0,76531 \text{ s} (0,77 \text{ s})$ ✓</p>	<p>Downward positive $F_{\text{net}}\Delta t = m(v_f - v_i)$ ✓ $mg\Delta t = m(v_f - v_i)$ $(9,8)\Delta t = 0 - (-7,5)$ ✓ $\therefore \Delta t = 0,76531 \text{ s} (0,77 \text{ s})$ ✓</p>

(3)

<p>13.3 OPTION 1 Upward positive - At highest point $v_f = 0$ $v_f^2 = v_i^2 + 2a\Delta y$ ✓ $0 = (7,5)^2 + (2)(-9,8)\Delta y$ ✓ $\Delta y = 2,87 (2,869) \text{ m}$ ✓ It is higher than height needed to reach point T (2,1 m) ✓ <u>therefore ball will pass point T.</u> ✓</p>	<p>Downward positive - At highest point $v_f = 0$ $v_f^2 = v_i^2 + 2a\Delta y$ ✓ $0 = (-7,5)^2 + (2)(9,8)\Delta y$ ✓ $\Delta y = -2,87 (-2,869) \text{ m}$ ✓ It is higher than height needed to reach point T (2,1 m) ✓ <u>therefore ball will pass point T.</u> ✓</p>
<p>OPTION 2 POSITIVE MARKING FROM Q13.2. Upward positive $\Delta y = v_i\Delta t + \frac{1}{2}a\Delta t^2$ ✓ $\Delta y = (7,5)(0,77)$ ✓ + $\frac{1}{2}(-9,8)(0,77)^2$ ✓ $\Delta y = 2,87 \text{ m} (2,86 \text{ m})$ ✓ It is higher than height needed to reach point T (2,1 m) ✓ <u>therefore ball will pass point T.</u> ✓</p>	<p>Downward positive $\Delta y = v_i\Delta t + \frac{1}{2}a\Delta t^2$ ✓ $\Delta y = (-7,5)(0,77)$ ✓ + $\frac{1}{2}(9,8)(0,77)^2$ ✓ $\Delta y = -2,87 \text{ m} (2,869 \text{ m})$ ✓ It is higher than height needed to reach point T (2,1 m) ✓ <u>therefore ball will pass point T.</u> ✓</p>

(6)

13.4 **POSITIVE MARKING FROM QUESTION 13.2.**

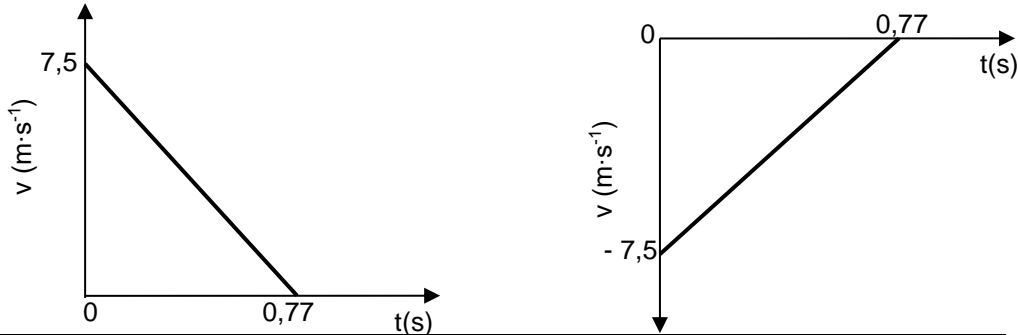

Marking criteria
Initial velocity and time for final velocity shown. ✓
Correct straight line (including orientation) drawn. ✓

(2)
[13]

MOMENTUM AND IMPULSE

QUESTION 1

1.1 $p = mv$ ✓
 $= 50(5)$ ✓ $= 250 \text{ kg}\cdot\text{m}\cdot\text{s}^{-1}$ ✓ (downward) **OR** $p = mv$ ✓ $= 50(-5)$ ✓ $= -250 \text{ kg}\cdot\text{m}\cdot\text{s}^{-1}$
 $\therefore 250 \text{ kg}\cdot\text{m}\cdot\text{s}^{-1}$ ✓ (downward) (3)

1.2 The product of the net force and the time interval during which the force acts. ✓✓ (2)

1.3 $\Delta p = F_{\text{net}}\Delta t$ ✓
 $0 - 250$ ✓ $= F_{\text{net}}(0,2)$
 $F_{\text{net}} = -1\,250 \text{ N}$ $\therefore F_{\text{net}} = 1\,250 \text{ N}$ ✓ $\Delta p = F_{\text{net}}\Delta t$ ✓
 $250 - 0$ ✓ $= F_{\text{net}}(0,2)$
 $F_{\text{net}} = 1\,250 \text{ N}$ ✓ $\Delta p = F_{\text{net}}\Delta t$ ✓
 $50(0 - (-5))$ ✓ $= F_{\text{net}}(0,2)$
 $F_{\text{net}} = 1\,250 \text{ N}$ ✓ (3)

1.4 Greater than ✓ (1)

1.5 For the same momentum change, ✓
the stopping time (contact time) ✓ will be smaller (less), ✓
 \therefore the (upward) force exerted (on her) is greater. (3)
[12]

QUESTION 2

2.1 Momentum is the product of an object's mass and its velocity. ✓✓ (2)

2.2 **Direction of motion positive:**
 $\Delta p = mv_f - mv_i$ ✓
 $= (175)(0 - (+20))$ ✓ $= -3\,500 \text{ kg}\cdot\text{m}\cdot\text{s}^{-1}$ ✓
 $\therefore \Delta p = 3\,500 \text{ kg}\cdot\text{m}\cdot\text{s}^{-1}$ opposite to direction of motion ✓ **Direction of motion negative:**
 $\Delta p = mv_f - mv_i$ ✓
 $= (175)(0 - (-20))$ ✓ $= 3\,500 \text{ kg}\cdot\text{m}\cdot\text{s}^{-1}$ ✓
 $\therefore \Delta p = 3\,500 \text{ kg}\cdot\text{m}\cdot\text{s}^{-1}$ opposite to direction of motion ✓ (4)

2.3 **Direction of motion positive:**
 $F_{\text{net}}\Delta t = \Delta p$ ✓
 $f(8) = -3\,500$ ✓
 $f = -437,5 \text{ N}$ ✓
 $\therefore f = 437,5 \text{ N}$ opposite to direction motion ✓ **Direction of motion negative:**
 $F_{\text{net}}\Delta t = \Delta p$ ✓
 $f(8) = 3\,500$ ✓
 $f = 437,5 \text{ N}$ ✓
 $\therefore f = 437,5 \text{ N}$ opposite to direction of motion ✓ (4)
[10]

QUESTION 3

3.1 A collision in which both total momentum and total kinetic energy are conserved. ✓✓ (2)

OPTION 1

For ball A
 $(E_{\text{mech}})_{\text{top}} = (E_{\text{mech}})_{\text{bottom}}$
 $(E_K + E_P)_{\text{top}} = (E_K + E_P)_{\text{bottom}}$
 $(\frac{1}{2}mv^2 + mgh)_{\text{top}} = (\frac{1}{2}mv^2 + mgh)_{\text{bottom}}$
 $\frac{1}{2}(0,2)(0)^2 + (0,2)(9,8)(0,2)_{\text{top}} = E_K + m(9,8)(0)_{\text{bottom}}$ ✓
 $E_K = 0,39 \text{ J}$ ✓ } Any one ✓

OPTION 2

$W_{\text{nc}} = \Delta E_p + \Delta E_k$ ✓ $\therefore 0 = mg(h_f - h_i) + \frac{1}{2}m(v_f^2 - v_i^2)$
 $0 = (0,2)(9,8)(0,2 - 0) + \frac{1}{2}mv_f^2 - \frac{1}{2}(0,2)(0)^2$ ✓ $\therefore E_K = 0,39 \text{ J}$ ✓ (3)

3.3 **POSITIVE MARKING FROM QUESTION 3.2.**

$$\left. \begin{aligned} \Sigma E_{K\text{before}} &= \Sigma E_{K\text{after}} \\ E_{KIA} + E_{KIB} &= E_{KfA} + E_{KfB} \\ E_{KIA} + E_{KIB} &= \frac{1}{2} m_A v_{fA}^2 + E_{KfB} \end{aligned} \right\} \checkmark \text{Any one}$$

$$0,39 + 0 \checkmark = \frac{1}{2} (0,2) v_{fA}^2 + 0,12 \checkmark \therefore v_{fA} = 1,64 \text{ m}\cdot\text{s}^{-1} \checkmark \quad (4)$$

3.4 **POSITIVE MARKING FROM QUESTION 3.2.**

$$E_{K\text{before}} = \frac{1}{2} m_A v_{iA}^2 \therefore 0,39 = \frac{1}{2} (0,2) v_{iA}^2 \checkmark \therefore v_{iA} = 1,98 \text{ m}\cdot\text{s}^{-1}$$

$$\left. \begin{aligned} \text{Impulse} &= m(v_f - v_i) \\ \text{Impulse} &= m(v_{iA} - v_{fA}) \end{aligned} \right\} \checkmark \text{Any one}$$

$$= 0,2(-1,64) \checkmark - (0,2)(1,98) \checkmark = 0,72 \text{ N}\cdot\text{s} \checkmark \quad (5)$$

[14]

QUESTION 4

<p>4.1 OPTION 1 Take motion to the right as positive. $\Sigma p_i = \Sigma p_f$ $(m_1 + m_2)v_i = m_1 v_{f1} + m_2 v_{f2}$ $(3 + 0,02)(0) \checkmark = (3)(-1,4) + (0,02) v_{f2} \checkmark$ $v_{f2} = 210 \text{ m}\cdot\text{s}^{-1} \checkmark$</p>	<p>OPTION 2 Take motion to the left as positive. $\Sigma p_i = \Sigma p_f$ $(m_1 + m_2)v_i = m_1 v_{f1} + m_2 v_{f2}$ $(3 + 0,02)(0) \checkmark = (3)(1,4) + (0,02) v_{f2} \checkmark$ $v_{f2} = -210 \text{ m}\cdot\text{s}^{-1} \therefore \text{speed} = 210 \text{ m}\cdot\text{s}^{-1} \checkmark$</p>
---	--

(4)

4.2 **POSITIVE MARKING FROM QUESTION 4.1.**

<p>OPTION 1 $v_f^2 = v_i^2 + 2a\Delta x \checkmark$ $0 = 210^2 + 2a(0,4) \checkmark$ $a = -55\,125 \text{ m}\cdot\text{s}^{-2}$</p> <p>$F_{\text{net}} = ma \checkmark$ $= (0,02)(-55\,125) \checkmark$ $= -1\,102,5 \text{ N}$ Magnitude of force = 1 102,5 N \checkmark</p>	<p>OPTION 2 $\Delta x = \left(\frac{v_i + v_f}{2} \right) \Delta t \checkmark \therefore 0,4 = \left(\frac{210 + 0}{2} \right) \Delta t \checkmark$ $\therefore \Delta t = 0,004 \text{ s} (0,00381\text{s})$ $F_{\text{net}} \Delta t = \Delta p = m \Delta v \checkmark \therefore F_{\text{net}} = \frac{(0,02)(0 - 210)}{0,004} \checkmark$ $= -1\,050 \text{ N}$ Magnitude of force = 1 050 N \checkmark</p>
---	---

(5)

4.3 The same as/equal \checkmark (1)

[10]

QUESTION 5

5.1 The total (linear) momentum of an isolated/(closed system) \checkmark is constant/conserved. \checkmark (2)

5.2.1 $\Sigma p_i = \Sigma p_f \checkmark$
 $m_1 v_{1i} + m_2 v_{2i} = m_1 v_{1f} + m_2 v_{2f}$
 $(m_1 + m_2)v_i = m_1 v_{1f} + m_2 v_{2f}$

$0 \checkmark = (0,4)v_{1f} + 0,6(4) \checkmark$
 $v_{1f} = -6 \text{ m}\cdot\text{s}^{-1}$
 $= 6 \text{ m}\cdot\text{s}^{-1} \text{ to the left/na links} \checkmark$ (4)

<p>5.2.2 OPTION 1 $\Delta p = F_{\text{net}} \Delta t \checkmark$ $[(0,6)(4) - 0] \checkmark = F_{\text{net}} (0,3) \checkmark$ $F_{\text{net}} = 8 \text{ N} \checkmark$</p> <p>OR/OF $m(v_f - v_i) = F_{\text{net}} \Delta t \checkmark$ $0,6(4 - 0) \checkmark = F_{\text{net}}(0,3) \checkmark$ $F_{\text{net}} = 8 \text{ N} \checkmark$</p>	<p>OPTION 2 $v_f = v_i + a \Delta t$ $4 = 0 + a(0,3)$ $a = 13,33 \text{ m}\cdot\text{s}^{-2}$</p> <p>$F_{\text{net}} = ma$ $= 0,6(13,33)$ $F_{\text{net}} = 8 \text{ N} \checkmark$</p>	<p>OPTION 3 $\Delta p = F_{\text{net}} \Delta t \checkmark$ $[(0,4)(6) - 0] \checkmark = F_{\text{net}} (0,3) \checkmark$ $F_{\text{net}} = 8 \text{ N} \checkmark$</p> <p>OR/OF $m(v_f - v_i) = F_{\text{net}} \Delta t \checkmark$ $0,4(6 - 0) \checkmark = F_{\text{net}}(0,3) \checkmark$ $F_{\text{net}} = 8 \text{ N} \checkmark$</p>
---	--	---

(4)

5.3 No \checkmark (1)

[11]

QUESTION 6

6.1 The total (linear) momentum of an isolated/closed system \checkmark is constant/conserved. \checkmark (2)

<p>6.2.1 OPTION 1 $\Sigma p_i = \Sigma p_f$ $m_1 v_{1i} + m_2 v_{2i} = m_1 v_{1f} + m_2 v_{2f}$ $m_1 v_{1i} + m_2 v_{2i} = (m_1 + m_2)v_f$ $(5)(4) + (3)(0) \checkmark = (5 + 3)v_f \checkmark \therefore v = 2,5 \text{ m}\cdot\text{s}^{-1} \checkmark$</p>	<p>OPTION 2 $\Delta p_{5\text{kg}} = -\Delta p_{3\text{kg}} \checkmark$ $m v_f - m v_i = m v_f - m v_i$ $5v_f - (5)(4) \checkmark = 3v_f - (3)(0) \checkmark$ $v_f = 2,5 \text{ m}\cdot\text{s}^{-1} \checkmark$</p>
--	---

(4)

6.2.2 **POSITIVE MARKING FROM QUESTION 6.2.1.**

OPTION 1 $F_{net}\Delta t = \Delta p = (p_f - p_i) = (mv_f - mv_i) \checkmark \therefore \underline{F_{net}(0,3)} \checkmark = 8 [(0 - (-2,5))] \checkmark$ $\therefore F_{net} = -66,67 \text{ N} \quad \therefore F_{net} = 66,67 \text{ N} \checkmark$	
OPTION 2 $F_{net} = ma \checkmark = \frac{m(v_f - v_i)}{\Delta t} = \frac{8(0 - 2,5)}{0,3} \checkmark$ $= -66,67 \text{ N} \quad \therefore F_{net} = 66,67 \text{ N} \checkmark$	OPTION 3 $v_f = v_i + a\Delta t \therefore 0 = 2,5 + a(0,3) \checkmark \therefore a = -8,333 \text{ m}\cdot\text{s}^{-2}$ $F_{net} = ma \checkmark = 8(-8,333) \checkmark = -66,67 \text{ N}$ $\therefore F_{net} = 66,67 \text{ N} \checkmark$

(4)
[10]

QUESTION 7

7.1 A system on which the resultant/net external force is zero. \checkmark (1)

OPTION 1 $p = mv \checkmark \therefore \underline{30\,000 = (1\,500)v} \checkmark$ $\therefore v = 20 \text{ m}\cdot\text{s}^{-1} \checkmark$	OPTION 2 $\Delta p = mv_f - mv_i \checkmark \therefore \underline{0 = (1\,500)v_f - 30\,000} \checkmark$ $\therefore v = 20 \text{ m}\cdot\text{s}^{-1} \checkmark$
--	--

(3)

7.2.2 **POSITIVE MARKING FROM QUESTION 7.2.1.**

OPTION 1 $\Sigma p_i = \Sigma p_f$ $m_1 v_{1i} + m_2 v_{2i} = m_1 v_{1f} + m_2 v_{2f} \checkmark$ $\underline{30\,000 + (900)(-15)} \checkmark = \underline{14\,000 + 900v_B} \checkmark$ $\therefore v_B = 2,78 \text{ m}\cdot\text{s}^{-1} \checkmark \text{ east} \checkmark$	OPTION 2 $\Delta p_A = -\Delta p_B \checkmark$ $p_f - p_i = -(mv_f - mv_i) \checkmark$ $\underline{14\,000 - 30\,000} \checkmark = \underline{900v_f - 900(-15)} \checkmark$ $v_f = 2,78 \text{ m}\cdot\text{s}^{-1} \checkmark \text{ east}$
---	--

(5)

OPTION 1 $\text{Slope} = \frac{\Delta p}{\Delta t} = F_{net} \checkmark = \frac{(14\,000 - 30\,000)}{20,2 - 20,1} \checkmark$ $= -160\,000 \therefore F_{net} = 160\,000 \text{ N} \checkmark$	OPTION 2 $F_{net}\Delta t = \Delta p \checkmark$ $F_{net}(0,1) \checkmark = \underline{14\,000 - 30\,000} \checkmark$ $F_{net} = -160\,000 \text{ N}$ $F_{net} = 160\,000 \text{ N} \checkmark$
---	--

POSITIVE MARKING FROM QUESTION 7.2.2.

OPTION 3 $F_{net}\Delta t = \Delta p \checkmark \therefore \underline{F_{net}(0,1)} \checkmark = \underline{900[(2,78) - (-15)]} \checkmark \therefore F_{net} = -160\,020 \text{ N}$ $F_A = -F_B \therefore F_{net} = 160\,020 \text{ N} \checkmark$
--

(4)
[13]

QUESTION 8

$v = \frac{\Delta x}{\Delta t} = \frac{0,2}{0,4} = 0,5 \text{ m}\cdot\text{s}^{-1}$	$v = \frac{\Delta x}{\Delta t} = \frac{0,4}{0,8} = 0,5 \text{ m}\cdot\text{s}^{-1}$	$v = \frac{\Delta x}{\Delta t} = \frac{0,6}{1,2} = 0,5 \text{ m}\cdot\text{s}^{-1}$
\checkmark Formula	\checkmark Correct substitution in all three equations.	\checkmark Arriving at correct answer.

(3)

8.2 The total linear momentum of a closed/isolated system is constant/is conserved. (2)

8.3 **POSITIVE MARKING FROM QUESTION 8.1.**

$\Sigma p_i = \Sigma p_f$ $m_1 v_{1i} + m_2 v_{2i} = m_1 v_{1f} + m_2 v_{2f} \checkmark$ $\underline{(3,5)(0,5)} \checkmark = \underline{(3,5 + 6)v_f} \checkmark$ $v_f = v_{6\text{kg}} = 0,184 \text{ m}\cdot\text{s}^{-1}$	
For trolley B: $F_{net}\Delta t = \Delta p = m\Delta v \checkmark$ $\underline{F_{net}(0,5)} = \underline{6(0,184 - 0)} \checkmark \therefore F_{net} = 2,21 \text{ N} \checkmark$ \therefore Magnitude of the average net force experienced by trolley B = 2,21 N \checkmark	For trolley A: $F_{net}\Delta t = \Delta p = m\Delta v \checkmark$ $\underline{F_{net}(0,5)} = \underline{3,5(0,184 - 0,5)} \checkmark \therefore F_{net} = -2,21 \text{ N} \checkmark$ \therefore Magnitude of the average net force experienced by trolley B = 2,21 N \checkmark

(6)
[11]

QUESTION 9

9.1 It is the product of the resultant/net force acting on an object \checkmark and the time the resultant/net force acts on the object. \checkmark (2)

9.2.1 $p = mv \checkmark = (0,03)(700) \checkmark = 21 \text{ kg}\cdot\text{m}\cdot\text{s}^{-1} \checkmark$ (3)

9.2.2 **POSITIVE MARKING FROM QUESTION 9.2.1.**

OPTION 1 $\Delta t \text{ for a bullet} = \frac{60}{220} \checkmark = 0,27 \text{ s}$ $F_{net}\Delta t = \Delta p = (p_f - p_i) = (mv_f - mv_i) \text{ OR } F_{ave \text{ gun on bullet}} = \frac{\Delta p}{\Delta t} = \frac{21 - 0}{0,27} \checkmark = 77,01 \text{ N} \checkmark (77,78 \text{ N})$ \therefore average force of bullet on gun = 77,01 N / 77,8 N to the west \checkmark
--

OPTION 2

$$F_{\text{net}}\Delta t = \Delta p = (p_f - p_i) = (mv_f - mv_i) \quad \left. \vphantom{F_{\text{net}}\Delta t} \right\} \checkmark \text{ Any one}$$

$$F_{\text{av}} = \frac{\Delta p}{\Delta t}$$

$$\Delta p_{\text{tot}} = (21)(220) \checkmark = 4\,620 \text{ kg}\cdot\text{m}\cdot\text{s}^{-1}$$

$$F_{\text{ave gun on bullet}} = \frac{4\,620 - 0}{60} \checkmark = 77,00 \text{ N} \checkmark$$

\therefore average force of bullet on gun = 77,01 N / 77,78 N to the west \checkmark

(5)

9.3

POSITIVE MARKING FROM 9.2.2.

77 N / 77,78 N \checkmark to the east \checkmark

(2)

[12]

QUESTION 10

10.1

The total linear momentum of a closed/isolated system is constant/conserved. $\checkmark\checkmark$

(2)

10.2

$$\Sigma p_i = \Sigma p_f$$

$$m_B v_{Bi} + m_b v_{bi} = m_B v_{Bf} + m_b v_{bf} \quad \left. \vphantom{m_B v_{Bi}} \right\} \checkmark \text{ Any one}$$

$$\Delta p_{\text{bullet}} = -\Delta p_{\text{block}}$$

$$(0,015)(400) \checkmark + 0 = (0,015)v_{Bf} + 2(0,7) \checkmark \quad \therefore v_{Bf} = 306,67 \text{ m}\cdot\text{s}^{-1} \checkmark$$

(4)

10.3

POSITIVE MARKING FROM 10.2.

OPTION 1

$$F_{\text{net}}\Delta t = \Delta p$$

$$\Delta p = mv_f - mv_i \quad \left. \vphantom{F_{\text{net}}\Delta t} \right\} \checkmark \text{ Any one}$$

For bullet:

$$\Delta p = (0,015)(306,666 - 400) \checkmark$$

$$= -1,4 \text{ kg}\cdot\text{m}\cdot\text{s}^{-1}$$

$$F_{\text{net}}(0,002) = -1,4 \quad \therefore F_{\text{net}} = -700 \text{ N}$$

For block:

$$\Delta p = (2)(0,7 - 0) \checkmark$$

$$= 1,4 \text{ kg}\cdot\text{m}\cdot\text{s}^{-1}$$

$$F_{\text{net}}(0,002) = 1,4 \quad \therefore F_{\text{net}} = 700 \text{ N}$$

$W_{\text{net}} = \Delta E_k$

$$F_{\text{net}}\Delta x \cos\theta = \frac{1}{2} m(v_f^2 - v_i^2)$$

$$(700)\Delta x \cos 180^\circ = \frac{1}{2}(0,015)(306,67^2 - 400^2) \checkmark$$

$$\therefore \Delta x = 0,71 \text{ m} \checkmark$$

$F_{\text{net}} = ma$

$$-700 = (0,015)a \text{ OR } 700 = (0,015)a$$

$$a = -46\,666,67 \text{ OR } 46\,665 \text{ m}\cdot\text{s}^{-2}$$

$\Delta x = v_i\Delta t + \frac{1}{2} a\Delta t^2$

$$= (400)(0,002) \checkmark + \frac{1}{2}(-46\,666,67)(0,002)^2 \checkmark$$

$$= 0,71 \text{ m } (0,70667) \text{ m} \checkmark$$

OR

$$v_f^2 = v_i^2 + 2a\Delta x$$

$$(306,67)^2 \checkmark = (400)^2 + 2(-46\,666,67)\Delta x \checkmark$$

$$\Delta x = 0,71 \text{ m } (0,70667) \text{ m} \checkmark$$

OPTION 2

$$v_f = v_i + a\Delta t \quad \therefore 306,666 = 400 + a(0,002) \checkmark \quad \therefore a = -46\,667 \text{ m}\cdot\text{s}^{-2}$$

$$v_f^2 = v_i^2 + 2a\Delta x \quad \therefore (306,666)^2 \checkmark = 400^2 + 2(-46\,667)\Delta x \checkmark \quad \therefore \Delta x = 0,71 \text{ m } (0,706) \text{ m} \checkmark$$

(5)

[11]

QUESTION 11

11.1

The total linear momentum of a closed/isolated system remains constant/is conserved. $\checkmark\checkmark$

(2)

11.2

$$\Sigma p_i = \Sigma p_f$$

$$m_1 v_{1i} + m_2 v_{2i} = m_1 v_{1f} + m_2 v_{2f} \quad \left. \vphantom{m_1 v_{1i}} \right\} \checkmark \text{ for any}$$

For the system cat-skate board **A**

$$(3,5)(0) + (2,6)(0) \checkmark = (3,5)v_{\text{skateboard}} + (2,6)(3) \checkmark \quad \therefore v_{\text{skateboard}} = 2,23 \text{ m}\cdot\text{s}^{-1} \checkmark \text{ to the left} \checkmark$$

(5)

11.3

<p>OPTION 1</p> $F_{\text{net}}\Delta t = \Delta p = mv_f - mv_i \checkmark$ $= (3,5)(1,28 - 0) \checkmark = 4,48 \text{ N}\cdot\text{s} \checkmark$	<p>OPTION 2</p> $F_{\text{net}}\Delta t = \Delta p = mv_f - mv_i \checkmark$ $= (2,6)(1,28 - 3) \checkmark = -4,48 \text{ N}\cdot\text{s} \checkmark$
---	--

(3)

[10]

QUESTION 12

12.1

$$E_{(\text{mech top})} = E_{(\text{mech bottom})}$$

$$(E_p + E_k)_{\text{top/bo}} = (E_p + E_k)_{\text{bottom}} \quad \left. \vphantom{E_{(\text{mech top})}} \right\} \checkmark \text{ for any}$$

$$(mgh + \frac{1}{2} mv^2)_{\text{top}} = (mgh + \frac{1}{2} mv^2)_{\text{bottom}}$$

$$(1,5)(9,8)(2) + 0 \checkmark = 0 + \frac{1}{2} (1,5)v^2 \checkmark \quad \therefore v = 6,26 \text{ m}\cdot\text{s}^{-1} \checkmark$$

(4)

12.2

The total linear momentum of a closed/isolated system is constant/conserved. $\checkmark\checkmark$

(2)

12.3 **POSITIVE MARKING FROM QUESTION 12.1.**

$\Sigma p_i = \Sigma p_f$ $m_1 v_{1i} + m_2 v_{2i} = m_1 v_{1f} + m_2 v_{2f}$ $m_1 v_{1i} + m_2 v_{2i} = (m_1 + m_2) v_f$ $(1,5)(6,26) + 0 = (1,5 + 2)v_f \therefore v_f = 2,68 \text{ m}\cdot\text{s}^{-1}$	}	✓ for any
---	---	-----------

(4)

12.4 **POSITIVE MARKING FROM Q12.3.**

<p>OPTION 1</p> $\Delta x = v \Delta t = (2,68)(3) = 8,04 \text{ m}$	<p>OPTION 2</p> $\Delta x = v_i \Delta t + \frac{1}{2} a \Delta t^2$ $= (2,68)(3) + \frac{1}{2} (0)(3)^2 = 8,04 \text{ m}$ (Range 8,04 – 8,05)
---	--

(3) [13]

QUESTION 13

13.1 Momentum is the product of the mass of an object and its velocity. ✓✓ (2)

13.2 To the left ✓
 Newton's third law ✓ (2)

NOTE: For QUESTIONS 13.3 and 13.4 motion to the right has been taken as positive.

13.3

<p>OPTION 1</p> $\Sigma p_i = \Sigma p_f$ $m_1 v_{1i} + m_2 v_{2i} = m_1 v_{2f} + m_2 v_{2f}$ mass of girl is m $\{(m + 2)(0)\} + \{8(0)\} = \{(m + 2)(-0,6)\} + (8)(4) \therefore m = 51,33 \text{ kg}$	<p>OPTION 3</p> $\Delta p_{\text{girl}} = -\Delta p_{\text{parcel}}$ $m(v_f - v_i) = -m(v_f - v_i)$ $(m + 2)(-0,6 - 0) = -8(4 - 0)$ $m = 51,33 \text{ kg}$
--	--

(5)

13.4 **POSITIVE MARKING FROM QUESTION 13.3.**

Impulse = $\Delta p = m(v_f - v_i) = (51,33 + 2)(-0,6 - 0) = -32 \text{ N}\cdot\text{s}/\text{kg}\cdot\text{m}\cdot\text{s}^{-1}$
 Magnitude of impulse is $32 \text{ N}\cdot\text{s} / 32 \text{ kg}\cdot\text{m}\cdot\text{s}^{-1}$

OR

Impulse = $\Delta p_{\text{parcel}} = m(v_f - v_i) = (8)(4 - 0) = 32 \text{ kg}\cdot\text{m}\cdot\text{s}^{-1} \therefore \Delta p_{\text{girl}} = 32 \text{ kg}\cdot\text{m}\cdot\text{s}^{-1}$

(3)

13.5 **POSITIVE MARKING FROM QUESTION 13.4.**
 $32 \text{ kg}\cdot\text{m}\cdot\text{s}^{-1}$ ✓ to the right/opposite direction ✓ (2) [14]

WORK, ENERGY AND POWER

QUESTION 1

1.1.1 In an isolated/closed system, ✓ the total mechanical energy is conserved/remains constant. ✓ (2)

1.1.2 No ✓ (1)

1.1.3

<p>OPTION 1</p> <p>Along AB</p> $E_{\text{mech at A}} = E_{\text{mech at B}}$ $(E_p + E_k)_A = (E_p + E_k)_B$ $(mgh + \frac{1}{2} mv^2)_A = (mgh + \frac{1}{2} mv^2)_B$ $(10)(9,8)(4) + 0 = 0 + \frac{1}{2} (10) v_f^2$ $v_f = 8,85 \text{ m}\cdot\text{s}^{-1}$	<p>OPTION 2</p> <p>Along AB</p> $W_{\text{net}} = \Delta E_k$ $F_g \Delta h \cos \theta = \frac{1}{2} m(v_f^2 - v_i^2)$ $(10)(9,8)(4) \cos 0^\circ = \frac{1}{2} (10)(v_f^2 - 0)$ $v_f = 8,85 \text{ m}\cdot\text{s}^{-1}$
<p>Substitute 8,85 m·s⁻¹ in one of the following options</p>	
<p>Along BC</p> $W_{\text{net}} = \Delta K \therefore f \Delta x \cos \theta = \Delta K$ $f(8) \cos 180^\circ = \frac{1}{2} (10)(0 - 8,85^2)$ $f = 48,95 \text{ N}$	<p>Along BC</p> $W_{\text{nc}} = \Delta K + \Delta U \therefore f \Delta x \cos \theta = \Delta K + \Delta U$ $f(8) \cos 180^\circ = \frac{1}{2} (10)(0 - 8,85^2) + 0$ $f = 48,95 \text{ N}$

(6)

1.2.1 $f_k = \mu_k N = \mu_k mg \cos \theta = (0,19)(300)(9,8) \cos 25^\circ = 506,26 \text{ N}$ ✓ (3)

1.2.2 **POSITIVE MARKING FROM QUESTION 1.2.1.**

	$F_{net} = 0 \quad \text{OR} \quad F_{app} + (-F_g \sin \theta) + (-f) = 0 \checkmark$ $F_{app} - (300)(9,8) \sin 25^\circ - 506,26 = 0$ $F_{app} = 1\,748,76 \text{ N}$ $P_{ave} = F v_{ave} \checkmark = 1748,76 \times 0,5 \checkmark = 874,38 \text{ W} \checkmark$
--	---

(6)
[18]

QUESTION 2

2.1 $\Delta U + \Delta K = 0 \checkmark$
 $(5)(9,8)(5) + 0 \checkmark + (0 + \frac{1}{2}(5v_f^2)) \checkmark = 0$
 $v_f = \sqrt{2 \times 9,8 \times 5}$
 $= 9,90 \text{ m}\cdot\text{s}^{-1} \checkmark (9,899 \text{ m}\cdot\text{s}^{-1})$ (4)

2.2 No friction/zero resultant force \checkmark and thus no loss in energy. \checkmark
OR Only conservative forces are present. **OR** Mechanical energy is conserved. (2)

2.3 The force for which the work done is path dependent. $\checkmark \checkmark$ (2)

2.4	<p>OPTION 1 $W_{nc} = \Delta U + \Delta K \checkmark$ $F \Delta x \cos \theta = \Delta U + \Delta K$ $(18 \Delta x \cos 180^\circ) = (5)(9,8)(3 - 0) \checkmark + \frac{1}{2}(5)(0 - 9,90^2) \checkmark$ $\Delta x = 5,4458 \text{ m} \checkmark$ $\theta = \sin^{-1} \frac{3}{5,4458} \checkmark$ $\theta = 33,43^\circ \checkmark$</p> <p>OPTION 2 $W_{net} = W_f + W_G \checkmark$ $W_{net} = -f \Delta x \cos \theta + m g \sin \theta \Delta x \cos \theta$ $= [(18) \Delta x \cos 180^\circ] + 5(9,8) \frac{3}{\Delta x} (\Delta x) \cos 180^\circ \checkmark$ $= -18 \Delta x - 147$ $W_{net} = \Delta K \checkmark$ $\Delta K = \frac{1}{2}(5)(0 - 9,90^2) \checkmark$ $= -245,025$ $-18 \Delta x - 147 = -245,025$ $\Delta x = 5,4458 \text{ m} \checkmark$ $\theta = \sin^{-1} \frac{3}{5,4458} \checkmark$ $\theta = 39,43^\circ \checkmark$</p>
-----	---

(7)
[15]

QUESTION 3

3.1 If the work done in moving an object between two points depends on the path taken (then the force applied is non-conservative). $\checkmark \checkmark$ (2)

3.2.1 No \checkmark (1)

3.2.2 Since there is no acceleration, the net force is zero \checkmark hence net work done $(F_{net} \Delta x \cos \theta)$ must be zero. \checkmark (2)

<p>3.3 $F_{//} - (f + F) = 0 \checkmark$ OR $F = mg \sin \theta - f_k$ OR $F = m g \sin \theta - 266$ $F = [100(9,8) \sin 25^\circ] \checkmark - 266 \checkmark$ $F = 148,17 \text{ N} \checkmark$</p>	
---	--

(4)

3.4	<p>OPTION 1 $W = F \Delta x \cos \theta$ OR $W_{net} = W_f + W_g + W_N$ OR $W_{net} = f_k \Delta x \cos 180^\circ \checkmark + m g \sin \theta \Delta x \cos 0^\circ + 0$ $= (266)(3)(-1) \checkmark + [100(9,8) \sin 25^\circ (3)(1)] \checkmark + 0 = 444,5 \text{ J}$ $W_{net} = \Delta E_k / \Delta K = \frac{1}{2} m (v_f^2 - v_i^2) \checkmark$ $444,5 = \frac{1}{2} (100) (v_f^2 - 0) \checkmark \therefore v_f = 2,98 \text{ m}\cdot\text{s}^{-1} \checkmark$</p>
-----	--

OPTION 2
 $W_{nc} = \Delta E_p + \Delta E_k \checkmark$
 $f\Delta x \cos\theta \checkmark = (mgh_f - mgh_i) + (\frac{1}{2}mv_f^2 - \frac{1}{2}mv_i^2)$
 $266\Delta x \cos 180^\circ \checkmark = (0 - mgsin25^\circ \Delta x \cos 0^\circ) + (\frac{1}{2}mv_f^2 - 0)$
 $266(3)(-1) = [-100(9,8) \sin 25^\circ(3)(1)] \checkmark - \frac{1}{2}(100)(v_f^2 - 0) \checkmark \therefore v_f = 2,98 \text{ m}\cdot\text{s}^{-1} \checkmark$

OPTION 3 (POSITIVE MARKING FROM QUESTION 3.3.)
 $W_{net} = \Delta E_k \checkmark$
 $F_{net}\Delta x \cos\theta \checkmark = \frac{1}{2}m(v_f^2 - v_i^2)$
 $(148,17) \checkmark (3)\cos 0^\circ \checkmark = \frac{1}{2}(100)(v_f^2 - 0^2) \therefore 444,51 = 50v_f^2 \checkmark \therefore v_f = 2,98 \text{ m}\cdot\text{s}^{-1} \checkmark$

OPTION 4 (POSITIVE MARKING FROM QUESTION 3.3.)
 $F_{net} = ma \checkmark$
 $148,17 \checkmark = 100a \checkmark$
 $a = 1,48 \text{ m}\cdot\text{s}^{-2}$
 $v_f^2 = v_i^2 + 2a\Delta x \checkmark$
 $= 2(1,48)(3) \checkmark \therefore v_f = 2,98 \text{ m}\cdot\text{s}^{-1} \checkmark$

(6)
[15]

QUESTION 4

4.1

<p>OPTION 1 $v_{ave} = \frac{800}{75} \checkmark = 10,67 \text{ m}\cdot\text{s}^{-1}$ $P_{ave} = Fv_{ave} \checkmark$ $P_{ave} = (240)(10,67)$ $= 2\,560,8 \text{ W (2,56 kW)} \checkmark$</p>	<p>OPTION 2 $v_{ave} = \frac{800}{75} \checkmark = 10,67 \text{ m}\cdot\text{s}^{-1}$ Distance covered in 1 s = 10,67m $\therefore W(\text{Work done in 1 s}) = F\Delta x \cos\theta \checkmark$ $= (240)(10,67)(1)$ $= 2\,560,8 \text{ J s}^{-1}$ $\therefore P_{ave} = 2\,560,8 \text{ W (2,56 kW)} \checkmark$</p>
<p>OPTION 3 $P = \frac{W}{\Delta t} \checkmark = \frac{F\Delta x \cos\theta}{\Delta t} = \frac{(240)(800) \cos 0^\circ}{75} \checkmark$ $= 2\,560 \text{ W} \checkmark$</p>	<p>OPTION 4 $P = \frac{W}{\Delta t} \checkmark = \frac{F\Delta x \cos\theta}{\Delta t} = \frac{(240)(800) \cos 0^\circ}{75} \checkmark$ $= 2\,560 \text{ W} \checkmark$</p>

(3)

4.2

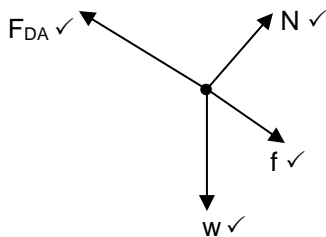

Accepted labels	
w	F _g /F _w /weight/mg/gravitational force/2 940 N
f	F _{friction} /F _f /friction/294 N/f _k
N	F _N /F _{normal} /normal force
F _D	F _{Applied} /350 N/Average driving force/F _{driving force}

(4)

4.3

The net/total work done on an object is equal \checkmark to the change in the object's kinetic energy. \checkmark

(2)

4.4

OPTION 1
 $W_{nc} = \Delta U + \Delta K \checkmark$
 $W_f + W_D = \Delta U + \Delta K$
 $(f\Delta x \cos\theta + F_D \Delta x \cos\theta = mg(h_f - h_i) + \frac{1}{2}m(v_f^2 - v_i^2)$
 $(294)(450)(\cos 180^\circ) \checkmark + (350)(450)\cos 0^\circ \checkmark = (300)(9,8)(5 - 0) \checkmark + \frac{1}{2}(300)(v_f^2 - 0) \checkmark$
 $v_f = 8,37 \text{ m}\cdot\text{s}^{-1} \checkmark$

OPTION 2
 $W_{net} = \Delta K \checkmark$
 $W_{net} = W_D + W_g + W_f + W_N$
 $= (F_D \Delta x \cos\theta) + (mg \sin\alpha) \Delta x \cos\theta + (f \Delta x \cos\theta) + 0$
 $W_{net} = [350(450)](\cos 0^\circ) \checkmark + (300)(9,8) \left(\frac{5}{450} (450)(\cos 180^\circ) \checkmark + 294(450)(\cos 180^\circ) \checkmark \right)$
 $= 157\,500 - 14\,700 - 132\,300 = 10\,500 \text{ J}$
 $W_{net} = \Delta K \therefore 10\,500 = \frac{1}{2}(300)(v_f^2 - 0) \checkmark \therefore v_f = 8,37 \text{ m}\cdot\text{s}^{-1} \checkmark$

(6)
[15]

QUESTION 5

5.1

It is a ratio of two forces (hence units cancel). \checkmark

(1)

5.2

The net/total work done on an object is equal \checkmark to the change in the object's kinetic energy. \checkmark

(2)

5.3

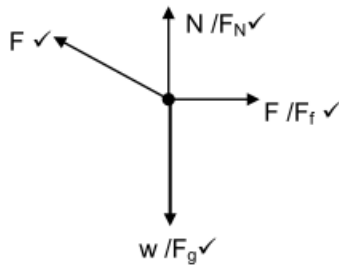

(4)

5.4

$$F \sin 20^\circ + N = mg$$

$$N = mg - F \sin 20^\circ$$

$$W_{fk} = f_k \Delta x \cos \theta = \mu_k N \Delta x \cos \theta$$

$$= \mu_k (mg - F \sin 20^\circ)(3) \cos \theta$$

$$= (0,2)[200(9,8) - F \sin 20^\circ](3) \cos 180^\circ$$

$$= (-1176 + 0,205 F) \text{ J}$$

(4)

5.5

$$W_{\text{tot}} = [W_g] + W_f + W_F$$

$$0 = [0] + [(-1176 + 0,205 F)] + [F (\cos 20^\circ) (3) (\cos 0^\circ)]$$

$$F = 388,88 \text{ N}$$

(4)

[15]

QUESTION 6

6.1

The total mechanical energy in an isolated/closed system remains constant/is conserved.

(2)

6.2.1

$$W = F \Delta x \cos \theta$$

$$= (30) \left(\frac{5}{\sin 30^\circ} \right) \cos \theta$$

$$= (30)(10) \cos 180^\circ$$

$$= (30)(10)(-1) = -300 \text{ J}$$

(3)

6.2.2

POSITIVE MARKING FROM QUESTION 6.2.1.

<p>OPTION 1</p> $W_{nc} = \Delta E_p + \Delta E_k$ $W_{nc} = mg(h_f - h_i) + \frac{1}{2}m(v_f^2 - v_i^2)$ $-300 = (20)(9,8)(0 - 5) + \frac{1}{2}(20)(v_f^2 - 0)$ $\therefore v = 8,25 \text{ m}\cdot\text{s}^{-1}$	} Any one ✓
<p>OPTION 2</p> $W_{net} = \Delta E_k$ $W_g + W_f = \frac{1}{2}m(v_f^2 - v_i^2)$ $(20)(9,8) \sin 30^\circ \left(\frac{5}{0,5} \cos 0^\circ \right) + (-300) = 10v_f^2$ $\therefore v_f = 8,25 \text{ m}\cdot\text{s}^{-1}$	} Any one ✓

(5)

6.3

$$F = w_f + f = (100)(9,8) \sin 30^\circ + 25 = 515 \text{ N}$$

$$P_{ave} = F v_{ave} = (515)(2) = 1030 \text{ W}$$

(4)

[14]

QUESTION 7

7.1

$$E_k = \frac{1}{2} m v^2 = \frac{1}{2} (2)(4,95)^2 = 24,50 \text{ J}$$

(3)

7.2

POSITIVE MARKING FROM QUESTION 7.1.1.

<p>OPTION 1</p> $E_{\text{mech before}} = E_{\text{mech after}}$ $[(E_{\text{mech}})_{\text{bob}} + (E_{\text{mech}})_{\text{block}}]_{\text{before}} = [(E_{\text{mech}})_{\text{block}} + (E_{\text{mech}})_{\text{bob}}]_{\text{after}}$ $(mgh + \frac{1}{2} m v^2)_{\text{before}} = (mgh + \frac{1}{2} m v^2)_{\text{after}}$ $(5)(9,8)h + 0 + 0 = 5(9,8)(\frac{1}{4}h) + 0 + 24,50$ $\therefore h = 0,67 \text{ m}$		} Any one ✓
<p>OPTION 2</p> $W_{nc} = \Delta E_p + \Delta E_k$ $0 = \Delta E_p + \Delta E_k$ $-\Delta E_p = \Delta E_k$ $-[(5)(9,8)(\frac{1}{4}h) - (5)(9,8)h] = 24,50$ $\therefore h = 0,67 \text{ m}$	<p>OPTION 3</p> <p>Loss E_p bob = Gain in E_k of block ✓</p> $mg(\frac{3}{4}h) = 24,5$ $(5)(9,8)(\frac{3}{4}h) = 24,5$ $\therefore h = 0,67 \text{ m}$	

(4)

7.3

The net/total work done on an object is equal to the change in the object's kinetic energy.

(2)

7.4

OPTION 1
 $W_{net} = \Delta E_K \checkmark$
 $W_f + mg\Delta y \cos\theta = \frac{1}{2}m(v_f^2 - v_i^2)$
 $W_f + (2)(9,8)(0,5)\cos 180^\circ \checkmark = \frac{1}{2}(2)(2^2 - 4,95^2) \checkmark \therefore W_f = -10,7 \text{ J} \checkmark$

OPTION 2
 $W_{nc} = \Delta E_K + \Delta U \checkmark$
 $W_{nc} = \Delta E_K + \Delta E_P \checkmark$
 $W_f = \frac{1}{2}(2)(2^2 - 4,95^2) \checkmark + (2)(9,8)(0,5-0) \checkmark = -10,7 \text{ J} \checkmark$

(4)
[13]

QUESTION 8

8.1

$W_{net} = \Delta K \checkmark$
 $W_{net} = \frac{1}{2}(M+m)(v_f^2 - v_i^2) \checkmark$

$W_{fr} = f\Delta x \cos\theta \checkmark = \frac{1}{2}(M+m)(v_f^2 - v_i^2)$
 $\frac{10 \times 2 \cos 180^\circ \checkmark = \frac{1}{2}(7,02)(0 - v_i^2) \checkmark$
 $v_{bb} = 2,39 \text{ m}\cdot\text{s}^{-1} \checkmark \quad (2,387) \text{ m}\cdot\text{s}^{-1}$

(5)

8.2

The total (linear) momentum of an isolated/closed system \checkmark is constant/conserved. \checkmark

(2)

8.3

POSITIVE MARKING FROM QUESTION 8.1.

$\Sigma p_i = \Sigma p_f \checkmark$
 $m_1 v_{1i} + m_2 v_{2i} = (m_1 + m_2) v_f$
 $0,02 v_i + (7)(0) = (7,02)(2,39)$
 $0,02 v_i \checkmark = 7,02 (2,39) \checkmark$
 $v_i = 838,89 \text{ m}\cdot\text{s}^{-1} \checkmark$

(4)
[11]

QUESTION 9

9.1

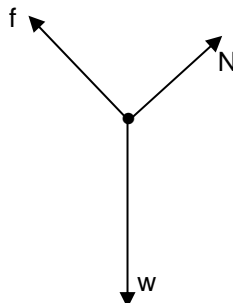

Accepted labels		
w	F _g /F _w /weight/mg/gravitational force	✓
f	Friction/F _f /50 N	✓
N	Normal force/F _{NORMAL} /F _{NOR}	✓

(3)

9.2

The net/total work done on an object equals the change in the object's kinetic energy. $\checkmark\checkmark$

(2)

9.3

OPTION 1
 $W_{net} = \Delta E_K$
 $f\Delta x \cos\theta + F_g \Delta x \cos\theta = \frac{1}{2}mv_f^2 - \frac{1}{2}mv_i^2 \checkmark$ } \checkmark Any one
 $(50)(25\cos 180^\circ) \checkmark + (60)(9,8)(25\cos 70^\circ) \checkmark = \frac{1}{2}(60)(15^2 - v_i^2) \checkmark$
 $-1\ 250 + 5\ 027,696 = 6\ 750 - 30 v_i^2 \therefore v_i = 9,95(4) \text{ m}\cdot\text{s}^{-1} \checkmark$

OPTION 2
 $W_{net} = \Delta E_K$
 $f\Delta x \cos\theta + F_{g\parallel} \Delta x \cos\theta = \frac{1}{2}mv_f^2 - \frac{1}{2}mv_i^2 \checkmark$ } \checkmark Any one
 $(50)(25\cos 180^\circ) \checkmark + (60)(9,8\sin 20^\circ)(25\cos 0^\circ) \checkmark = \frac{1}{2}(60)(15^2 - v_i^2) \checkmark$
 $-1\ 250 + 5\ 027,696 = 6\ 750 - 30 v_i^2 \therefore v_i = 9,95(4) \text{ m}\cdot\text{s}^{-1} \checkmark$

OPTION 3
 $W_{nc} = \Delta E_K + \Delta E_P$
 $f\Delta x \cos\theta = \frac{1}{2}(mv_f^2 - mv_i^2) + (mgh_Q - mgh_P) \checkmark$ } \checkmark Any one
 $E_{mechP} + E_{mechQ} + W_{nc} = 0$
 $(50)(25\cos 180^\circ) \checkmark = \frac{1}{2}(60)(15^2 - v_i^2) \checkmark + (60)(9,8)(-25\sin 20^\circ) \checkmark$
 $-1\ 250 = 6\ 750 - 30 v_i^2 - 5\ 027,696 \therefore v_i = 9,95(4) \text{ m}\cdot\text{s}^{-1} \checkmark$

(5)

9.4

POSITIVE MARKING FROM QUESTION 9.3.

OPTION 1
 $P_{ave} = F v_{ave} \checkmark = 50 \checkmark \frac{(9,95 + 15)}{2} \checkmark = 623,75 \text{ W} \checkmark$

OPTION 2

$$P = \frac{W}{\Delta t}$$

$$P = \frac{f \Delta x \cos \theta}{\Delta t}$$

$$= \frac{[50(25 \cos 180^\circ)]}{2,004} = -623,75 \text{ W} \checkmark$$

} Any one

$$\Delta x = \frac{(v_i + v_f)}{2} \Delta t$$

$$25 = \frac{(9,954 + 15)}{2} \Delta t \checkmark$$

$$\Delta t = 2,004 \text{ s}$$

(4)
[14]

QUESTION 10

10.1 The rate at which work is done. / Rate at which energy is expended. ✓✓ (2)

10.2

10.2.1

OPTION 1
 $W = F \Delta x \cos \theta \checkmark$
 $W_{\text{gravity}} = mg \Delta y \cos \theta = (1\,200)(9,8)(55) \cos 180^\circ \checkmark = -646\,800 \text{ J } (6,47 \times 10^5 \text{ J}) \checkmark$

OPTION 2
 $W = -\Delta E_p \checkmark = -(1200)(9,8)(55 - 0) \checkmark = -646800 \text{ J} \checkmark$

(3)

10.2.2 $W_{\text{counterweight}} = mg \Delta y \cos \theta = (950)(9,8)(55) \cos 0^\circ \checkmark = 512\,050 \text{ J} \checkmark \quad (5,12 \times 10^5 \text{ J})$ (2)

10.3

OPTION 1
POSITIVE MARKING FROM QUESTIONS 10.2.1 AND 10.2.2.
 $W_{\text{net}} = \Delta E_K$
 $W_{\text{gravity}} + W_{\text{counterweight}} + W_{\text{motor}} = 0$
 $W_{\text{motor}} = -(W_{\text{gravity}} + W_{\text{counterweight}})$
 $W_{\text{nc}} = \Delta E_K + \Delta E_p$
 Substituting into any of the above equations will lead to:
 $-646800 \checkmark + 512050 \checkmark + W_{\text{motor}} = 0$
 $\therefore W_{\text{motor}} = 134\,750 \text{ J} \quad \therefore P_{\text{av motor}} = \frac{W}{\Delta t} \checkmark = \frac{34750}{180} \checkmark = 748,61 \text{ W} \checkmark$

OPTION 2
 $F_{\text{net}} = 0 \quad \therefore F_{\text{gcage}} + F_{\text{gcount}} + F_{\text{motor}} = F_{\text{net}} \checkmark$
 $-117600 \checkmark + 9310 \checkmark + F_{\text{motor}} = 0 \quad \therefore F_{\text{motor}} = 2450 \text{ N}$
 $P_{\text{ave}} = F V_{\text{ave}} \checkmark = 2450 \frac{55}{180} \checkmark = 748,61 \text{ W}$

OPTION 3
 $P_{\text{ave}} = F V_{\text{ave}} \checkmark \checkmark = [1200 \checkmark (9,8) - 950 \checkmark (9,8)] \frac{55}{180} \checkmark = 748,61 \text{ W} \checkmark$

(6)
[13]

QUESTION 11

11.1 The net/total work done (on an object) is equal to the change in the object's kinetic energy. ✓✓ (2)

11.2

T

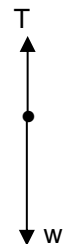

Accepted labels	
w✓	F _g / F _w / weight / mg / 58,8N / gravitational force / F _{earth on block}
T✓	F _T / Tension

(2)

11.3

$W_w = w \Delta x \cos \theta \checkmark = mg \Delta x \cos \theta$ $= (6)(9,8)(1,6) \cos 0^\circ \checkmark$ $\therefore W = 94,08 \text{ J} \checkmark$	$W_w = -\Delta E_p \checkmark = -mg(h_f - h_i)$ $= - (6)(9,8)(0 - 1,6) \checkmark$ $= 94,08 \text{ J} \checkmark$
---	---

(3)

11.4

POSITIVE MARKING FROM QUESTION 11.3.

OPTION 1

$$\left. \begin{aligned} W_{\text{net}} &= \Delta E_K / \Delta K = \frac{1}{2}m(v_f^2 - v_i^2) \\ W_{\text{net}} &= F_{\text{net}}\Delta x \cos\theta \\ W_{\text{net}} &= W_f + W_g + W_N \\ &= \mu_k N \Delta x \cos\theta + W_g + W_N \end{aligned} \right\} \checkmark \text{Any one}$$

$$W_{\text{net}} = (0,4)(4)(9,8)(1,6)\cos 180^\circ \checkmark + 94,08 + 0 = 68,992 \text{ J}$$

$$W_{\text{net}} = \frac{1}{2}m(v_f^2 - v_i^2) \quad \therefore \underline{68,992 \checkmark = \frac{1}{2}(4)(v_f^2 - 0) + \frac{1}{2}(6)(v_f^2 - 0) \checkmark} \quad \therefore v = 3,71 \text{ m}\cdot\text{s}^{-1} \checkmark$$

OPTION 2

$$\left. \begin{aligned} W_{\text{nc}} &= \Delta E_p + \Delta E_k \\ f\Delta x \cos\theta &= (m_1gh_f - m_1gh_i) + (\frac{1}{2}m_1v_f^2 - \frac{1}{2}m_1v_i^2) + (\frac{1}{2}m_2v_f^2 - \frac{1}{2}m_2v_i^2) \end{aligned} \right\} \checkmark \text{Any one}$$

$$(0,4)(4)(9,8)(1,6)\cos 180^\circ \checkmark = [0 - (6)(9,8)(1,6)] \checkmark + (\frac{1}{2}(6)v_f^2 + \frac{1}{2}(4)v_f^2 - 0) \checkmark \quad \therefore v = 3,71 \text{ m}\cdot\text{s}^{-1} \checkmark$$

OPTION 3

$$W_{\text{net}} = \Delta E_K \checkmark$$

For the 4 kg mass: $T(1,6)\cos 0^\circ + [(0,4)(9,8)(4)](1,6)\cos 180^\circ \checkmark = \frac{1}{2}(4)v^2 - 0$

For the 6 kg mass: $(6)(9,8)(1,6)\cos 0^\circ + T(1,6)\cos 180^\circ \checkmark = \frac{1}{2}(6)(v^2 - 0)$

Adding the two equations : $68,992 = \frac{1}{2}(4)v^2 + \frac{1}{2}(6)v^2 \checkmark \quad \therefore v = 3,71 \text{ m}\cdot\text{s}^{-1} \checkmark$

(5)
[12]

QUESTION 12

- 12.1 The total mechanical energy in a closed/isolated system is constant/conserved. $\checkmark \checkmark$ (2)
 $E_{\text{mech P}} = E_{\text{mech Q}}$ OR $(E_p + E_k)_P = (E_p + E_k)_Q$ OR $W_{\text{net}} = \Delta E_K$ OR $W_{\text{con}} = \Delta E_K$ OR
 $(mgh + \frac{1}{2}mv^2)_P = (mgh + \frac{1}{2}mv^2)_Q \checkmark$
 $(50)(9,8)3 + 0 \checkmark = 0 + \frac{1}{2}(50)v^2 \checkmark \quad \therefore v = 7,67 \text{ m}\cdot\text{s} \checkmark$ (4)

12.3

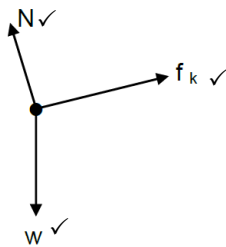

Accepted labels		
w	F _g /F _w /weight/mg/gravitational force	✓
f	Friction/F _f	✓
N	Normal force/F _{NORMAL} /F _N	✓

(3)

- 12.4 $f_k = \mu_k N$ OR $f_k = \mu_k mg \cos\theta \checkmark$
 $f_k = (0,08)(50)(9,8)\cos 30^\circ \checkmark = 33,95 \text{ N} \checkmark$ (3)

12.5 **POSITIVE MARKING FROM QUESTION 5.4/POSITIEWE NASIEN VANAF VRAAG 5.4**

$$\left. \begin{aligned} W &= F_{\text{net}}\Delta X \cos\theta \\ W_{\text{net}} &= W_f + W_w + W_N \\ W_{\text{net}} &= f_k + (-\Delta E_p) + W_N \\ W_{\text{net}} &= f_k \Delta X \cos 180^\circ + mgsin\theta \Delta x \cos 0 + 0 \\ W_{\text{net}} &= \Delta E_K / \Delta K \end{aligned} \right\} \begin{array}{l} \checkmark 1 \text{ mark for any one!} \\ 1 \text{ punt vir enige van die drie} \end{array}$$

$$W_{\text{net}} = [33,948(5)(-1)] \checkmark + [(50)(9,8)(5)\sin 30^\circ + 0] \checkmark$$

$$= 1055,26 \text{ (1055,259)}$$

$$\underline{1055,259 = \frac{1}{2}(50)(v_f^2 - 7,668^2) \checkmark}$$

$$v_f = 10,05 \text{ m}\cdot\text{s}^{-1} \checkmark$$

(5)
[17]

QUESTION 13

13.1



Accepted labels	
w	F _g /F _w /weight/mg/gravitational force/N/19,6 N
T	Tension/F _T / F _A /

(2)

- 13.2 Tension \checkmark OR F_{applied} (1)

13.3
$$\left. \begin{aligned} W &= F\Delta x \cos\theta \\ W_w &= mg\Delta x \cos\theta \end{aligned} \right\} \checkmark \text{ any one}$$

$$= 75(9,8)(12)\cos 180^\circ \checkmark = -8\,820 \text{ J } \checkmark$$
OR

$$W_w = -\Delta E_p \checkmark = -(mgh - 0) = -(75)(9,8)(12) \checkmark = -8\,820 \text{ J } \checkmark$$
 (3)

13.4 The net work done on an object is equal to the change in the object's kinetic energy. $\checkmark\checkmark$ (2)

13.5 **POSITIVE MARKING FROM QUESTION 13.3.**

OPTION 1

$$\left. \begin{aligned} W_{\text{net}} &= \Delta K \\ F_{\text{net}}\Delta x \cos\theta &= \left(\frac{1}{2}mv_f^2 - \frac{1}{2}mv_i^2\right) \checkmark \text{ any one} \\ (75)(0,65)(12) \checkmark \cos 0^\circ \checkmark &= \frac{1}{2}(75)(v_f^2 - 0) \checkmark \\ \therefore v_f &= 3,95 \text{ m}\cdot\text{s}^{-1} \checkmark \end{aligned} \right\}$$

OPTION 2

$$\left. \begin{aligned} W_{\text{net}} &= \Delta K \\ W_{\text{nc}} &= \Delta K + \Delta U \\ W_T + W_g &= \Delta K \\ T - mg &= ma \\ T - 75(9,8) &= 75(0,65) \checkmark \therefore T = 783,75 \text{ N} \\ W_T &= 783,75(12) \cos 0^\circ \checkmark = 9405 \text{ J} \\ 9405 - (8820) &= \frac{1}{2}(75)(v_f^2 - 0) \checkmark \therefore v_f = 3,95 \text{ m}\cdot\text{s}^{-1} \checkmark \end{aligned} \right\} \checkmark \text{ any one}$$

$$\begin{aligned} W_{\text{nc}} &= \left(\frac{1}{2}mv_f^2 - \frac{1}{2}mv_i^2\right) + (mgh_f - mgh_i) \\ 9405 \checkmark &= \left(\frac{1}{2}(75)v_f^2 - 0\right) \checkmark + (75)(9,8)(12 - 0) \checkmark \\ v_f &= 3,95 \text{ m}\cdot\text{s}^{-1} \checkmark \end{aligned}$$

(5)
[13]

QUESTION 14

14.1 A force for which the work done in moving an object between two points depends on the path taken. $\checkmark\checkmark$ (2)

14.2 No \checkmark (1)

14.3

<p>OPTION 1</p> $\begin{aligned} P &= \frac{W}{\Delta t} \checkmark \\ &= \frac{4,8 \times 10^6}{(90)} \checkmark \\ &= 53\,333,33 \text{ W} \\ &= 5,33 \times 10^4 \text{ W (53,33 kW)} \checkmark \end{aligned}$	<p>OPTION 2</p> $\begin{aligned} \Delta x &= \left(\frac{v_f + v_i}{2}\right) \Delta t \\ &= \left(\frac{0 + 25}{2}\right)(90) = 1\,125 \text{ m} \\ W_F &= F\Delta x \cos\theta \\ 4,80 \times 10^6 &= F(1\,125)\cos 0^\circ \therefore F = 4\,266,667 \text{ N} \\ P_{\text{ave}} &= Fv_{\text{ave}} \checkmark = (4\,266,667)(12,5) \checkmark \\ &= 53\,333,33 \text{ W } \checkmark \end{aligned}$
---	--

(3)

14.4 The net/total work done on an object is equal to the change in the object's kinetic energy. $\checkmark\checkmark$ (2)

14.5

OPTION 1

$$\begin{aligned} W_{\text{net}} &= \Delta K \checkmark \text{ OR } W_w + W_f + W_F = \frac{1}{2}mv_f^2 - \frac{1}{2}mv_i^2 \text{ OR} \\ mg\Delta x \cos\theta + W_f + W_F &= \frac{1}{2}mv_f^2 - \frac{1}{2}mv_i^2 \\ \therefore (1\,500)(9,8)(200)\cos 180^\circ \checkmark + W_f + 4,8 \times 10^6 \checkmark &= \frac{1}{2}(1\,500)(25^2 - 0) \checkmark \\ -2\,940\,000 + W_f + 4,8 \times 10^6 &= 468\,750 \therefore W_f = -1\,391\,250 \text{ J} = -1,39 \times 10^6 \text{ J } \checkmark \end{aligned}$$

OR

$$\begin{aligned} W_{\text{net}} &= \Delta K \checkmark \text{ OR } W_w + W_f + W_F = \frac{1}{2}mv_f^2 - \frac{1}{2}mv_i^2 \text{ OR } -\Delta E_p + W_f + W_F = \frac{1}{2}mv_f^2 - \frac{1}{2}mv_i^2 \\ \therefore -(1\,500)(9,8)(200 - 0) \checkmark + W_f + 4,8 \times 10^6 \checkmark &= \frac{1}{2}(1\,500)(25^2 - 0) \checkmark \\ -2\,940\,000 + W_f + 4,8 \times 10^6 &= 468\,750 \therefore W_f = -1\,391\,250 \text{ J} = -1,39 \times 10^6 \text{ J } \checkmark \end{aligned}$$

(5)

OPTION 2

$$\begin{aligned} W_{\text{nc}} &= \Delta K + \Delta U \checkmark \text{ OR } W_{\text{nc}} = \frac{1}{2}mv_f^2 - \frac{1}{2}mv_i^2 + mgh_f - mgh_i = \frac{1}{2}m(v_f^2 - v_i^2) + mg(h_f - h_i) \text{ OR} \\ W_{\text{nc}} &= \frac{1}{2}mv_f^2 + mgh_f - \frac{1}{2}mv_i^2 - mgh_i \text{ OR } W_f + W_F = \frac{1}{2}mv_f^2 - \frac{1}{2}mv_i^2 + mgh_f - mgh_i \checkmark \\ \therefore W_f + 4,8 \times 10^6 \checkmark &= \left[\frac{1}{2}(1\,500)(25)^2 + -0\right] \checkmark + [(1\,500)(9,8)(200) - 0] \checkmark \\ \therefore W_f &= -1,39 \times 10^6 \text{ J (-1,40} \times 10^6 \text{ J)} \checkmark \end{aligned}$$

OR

$$\begin{aligned} W_{\text{nc}} &= \Delta K + \Delta U \checkmark \text{ OR } W_{\text{nc}} = \frac{1}{2}mv_f^2 - \frac{1}{2}mv_i^2 + mgh_f - mgh_i = \frac{1}{2}m(v_f^2 - v_i^2) + mg(h_f - h_i) \text{ OR} \\ W_{\text{nc}} &= \frac{1}{2}mv_f^2 + mgh_f - \frac{1}{2}mv_i^2 - mgh_i \\ \therefore W_f + 4,8 \times 10^6 \checkmark &= \left[\frac{1}{2}(1\,500)(25)^2\right] \checkmark + (1\,500)(9,8)(200) \checkmark - [0 + 0] \\ \therefore W_f &= -4,8 \times 10^6 + 3,4 \times 10^6 = -1,39 \times 10^6 \text{ J (-1,40} \times 10^6 \text{ J)} \checkmark \end{aligned}$$

(5)
[13]

DOPPLER EFFECT**QUESTION 1**

1.1

1.1.1 An apparent change in observed/detected frequency/pitch/wavelength ✓ as a result of the relative motion between a source and an observer/listener. ✓ (2)

1.1.2 Towards ✓

Observed/detected frequency is greater than the actual frequency. ✓ (2)

1.1.3

$$f_L = \frac{v \pm v_L}{v \pm v_s} f_s \quad \text{OR} \quad f_L = \frac{v}{v - v_s} f_s \quad \checkmark$$

$$\therefore 1\,200 \checkmark = \frac{343 \checkmark}{343 - v_s} (1130) \checkmark \quad \therefore v_s = 20,01 \text{ m}\cdot\text{s}^{-1} \checkmark \quad (5)$$

1.2

- The star is approaching the earth. ✓
- OR:** The earth and the star are approaching (moving towards) each other. (2)
- The spectral lines in diagram 2 are shifted towards the blue end/are blue shifted. ✓ [11]

QUESTION 2

2.1.1

$$v = f\lambda \checkmark$$

$$\lambda = \frac{340}{520}$$

$$= 0,65 \text{ m} \checkmark \quad v = f \quad (2)$$

2.1.2

$$f_L = \frac{v \pm v_L}{v \pm v_s} f_s \checkmark$$

$$f_L = \frac{340 \checkmark}{(340 - 15) \checkmark} (520) \checkmark$$

$$f_L = 544 \text{ Hz}$$

$$v = f\lambda$$

$$\lambda = \frac{340}{544} \checkmark$$

$$= 0,63 \text{ m} \checkmark \quad (6)$$

2.2

The wavelength in QUESTION 2.1.2 is shorter because the waves are compressed as they approach the observer. ✓✓ (2)

2.3

The red shift occurs when the spectrum of a distant star moving away from the earth is shifted toward the red end of the spectrum. ✓✓ [12]

QUESTION 3

3.1

An apparent change in observed/detected frequency/pitch/wavelength ✓ as a result of the relative motion between a source and an observer/listener. ✓ (2)

3.2

$$f_L = \frac{v \pm v_L}{v \pm v_s} f_s \quad \text{OR} \quad f_L = \frac{v}{v - v_s} f_s \quad \checkmark$$

$$825 \checkmark = \frac{v}{v - v_s} (800) \checkmark$$

$$(1,03125)(v - 10) \checkmark = v$$

$$\therefore v = 330 \text{ m}\cdot\text{s}^{-1} \checkmark$$

The following values are obtained using other points:

v_s ($\text{m}\cdot\text{s}^{-1}$)	Frequencies	v ($\text{m}\cdot\text{s}^{-1}$)
$v_s = 20$	850	310
$v_s = 20$	845	375,56
$v_s = 30$	880	330
40	910	331

3.3

Straight line with negative gradient / frequency decreases (linearly). ✓✓

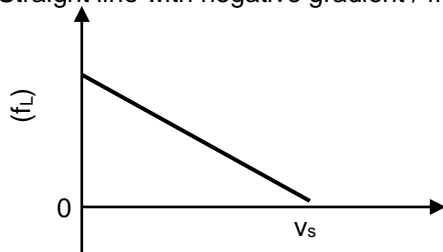
(2)
[9]

QUESTION 4

4.1.1 Frequency (of sound detected by the listener (observer)). ✓ (1)

4.1.2 An apparent change in observed/detected frequency/pitch/wavelength ✓ as a result of the relative motion between a source and an observer/listener. ✓ (2)

4.1.3 Away ✓ Detected frequency of source decreases. ✓ (2)

<p>EXPERIMENT 2</p> $f_L = \frac{v \pm v_L}{v \pm v_s} f_s \quad \text{OR} \quad f_L = \frac{v}{v + v_s} f_s \quad \checkmark$ $874 \checkmark = \frac{v \checkmark}{v + 10} (900) \checkmark \quad \therefore v = 336,15 \text{ m}\cdot\text{s}^{-1} \checkmark$	<p>EXPERIMENT 3</p> $f_L = \frac{v \pm v_L}{v \pm v_s} f_s \quad \text{OR} \quad f_L = \frac{v}{v + v_s} f_s \quad \checkmark$ $850 \checkmark = \frac{v \checkmark}{v + 20} (900) \checkmark \quad \therefore v = 340 \text{ m}\cdot\text{s}^{-1} \checkmark$
<p>EXPERIMENT 4</p> $f_L = \frac{v \pm v_L}{v \pm v_s} f_s \quad \text{OR} \quad f_L = \frac{v}{v + v_s} f_s \quad \checkmark$ $827 \checkmark = \frac{v \checkmark}{v + 30} (900) \checkmark \quad \therefore v = 339,86 \text{ m}\cdot\text{s}^{-1} \checkmark$	

(5)

4.2 Away from the earth. ✓ (1)

[11]**QUESTION 5**

5.1 $v = f\lambda \checkmark$
 $= (222 \times 10^3)(1,5 \times 10^{-3}) \checkmark$
 $= 333 \text{ m}\cdot\text{s}^{-1} \checkmark$ (3)

5.2.1 Towards the bat. ✓ (1)

5.2.2 $f_L = \frac{v \pm v_L}{v \pm v_s} f_s \quad \text{OR/OF} \quad f_L = \frac{v}{v - v_s} f_s \quad \checkmark$
 $230,3 = \frac{333}{333 - v_s} (222) \checkmark$
 $76689,9 - 230,3 v_s = 73\,926$ (6)
 $v = 12 \text{ m}\cdot\text{s}^{-1} \checkmark$ (towards bat/na die vlermuis toe) **[10]**

QUESTION 6

6.1 **X** ✓ (1)

6.2 As ambulance approaches the hospital the waves are compressed ✓ or wavelengths are shorter. Since the speed of sound is constant ✓ the observed frequency must increase. ✓ Therefore the hospital must be located on the side of X (from $v = f\lambda$)
OR: The number of wave fronts per second reaching the observer are more at X. ✓ ✓. For the same constant speed, this means that the observed frequency increases ✓ therefore the hospital must be located on the side of X. (from $v = f\lambda$) (3)

6.3 $f_L = \frac{v \pm v_L}{v \pm v_s} f_s \quad \text{OR} \quad f_L = \frac{v}{v - v_s} f_s \quad \checkmark \quad \therefore f_L = \frac{340}{340 - 30} (400) \checkmark \quad \therefore f_L = 438,71 \text{ Hz} \checkmark$ (5)

6.4 $v = f\lambda \checkmark \quad \therefore 340 = 400\lambda \checkmark \quad \therefore \lambda = 0,85 \text{ m} \checkmark$ (3)

[12]**QUESTION 7**

7.1.1 An apparent change in observed/detected frequency/pitch/wavelength ✓ as a result of the relative motion between a source and an observer/listener. ✓ (2)

7.1.2 $v = f\lambda \checkmark \quad \therefore 340 = f(0,28) \checkmark \quad \therefore f_s = 1\,214,29 \text{ Hz} \checkmark$ (3)

7.1.3 **POSITIVE MARKING FROM QUESTION 7.1.2.**

$f_L = \frac{v \pm v_L}{v \pm v_s} f_s \quad \text{OR} \quad f_L = \frac{v \pm v_L}{v \pm v_s} \times \frac{v}{\lambda_s} \quad \text{OR} \quad f_L = \frac{v}{v - v_s} f_s \quad \checkmark$
 $f_L = \left(\frac{340 \checkmark}{340 - 30} \right) 1214,29 \checkmark \quad \text{OR} \quad f_L = \left(\frac{340}{340 - 30} \right) \times \frac{340}{0,28} \quad \therefore f_L = 1\,331,80 \text{ Hz} \checkmark$ (5)

- 7.1.4 Decreases ✓ (1)
- 7.2 The spectral lines of the star are/should be shifted towards the lower frequency end, ✓ which is the red end (red shift) of the spectrum. ✓ (2)
- [13]

QUESTION 8

- 8.1 Speed ✓ (1)
- 8.2 $3 \text{ m}\cdot\text{s}^{-1}$ ✓ (1)
- 8.3.1 An apparent change in observed/detected frequency/pitch/wavelength ✓ as a result of the relative motion between a source and an observer/listener. ✓ (2)
- 8.3.2 $345 \text{ m}\cdot\text{s}^{-1}$ ✓ (1)
- 8.3.3 $f_L = \frac{v \pm v_L}{v \pm v_s} f_s = \left(\frac{345 + 0}{345 - 57,5} \right) \left(\frac{1000}{1} \right) = 1\,200 \text{ Hz}$ ✓ (4)
- 8.3.4 295 ✓ (K) (1)
- 8.4.1 Diagram 3 ✓ (1)
- 8.4.2 1 ✓  The source is stationary. ✓ (2)
- [13]

QUESTION 9

- 9.1.1 An apparent change in observed/detected frequency/pitch/wavelength ✓ as a result of the relative motion between a source and an observer/listener. ✓ (2)
- 9.1.2 $f_L = \frac{v \pm v_L}{v \pm v_s} f_s$ OR $f_L = \frac{v}{v - v_s} f_s$ ✓
- $365 = \frac{(340 + 0)}{(340 - v_s)} \times 330$ ✓ $\therefore v_s = 32,60 \text{ m}\cdot\text{s}^{-1}$ ✓ (5)
- 9.2 According to the Doppler Effect if the star moves away ✓ from the observer a lower frequency/longer wavelength ✓ is detected. This lower frequency/ longer wavelength corresponds to the the red end ✓ of the spectrum. (3)
- [10]

QUESTION 10

- 10.1.1 The Doppler effect ✓ (1)
- 10.1.2 Measuring the rate of blood flow. ✓ OR: Ultrasound (scanning) (1)
- 10.1.3 $f_L = \frac{v \pm v_L}{v \pm v_s} f_s$ OR $f_L = \frac{v}{v - v_s} f_s$ OR $f_L = \frac{v}{v + v_s} f_s$ ✓
- $2600 = \frac{340}{(340 - v_s)} f_s$
- $1750 = \frac{340}{(340 + v_s)} f_s$ ✓ $\therefore 2600(340 - v_s) = 1750(340 + v_s)$ ✓ $\therefore v_s = 66,44 \text{ m}\cdot\text{s}^{-1}$ ✓ (6)
- 10.1.4 (a) Increase ✓ (1)
- (b) Decrease ✓ (1)
- 10.2.1 The spectral lines (light) from the star are shifted towards longer wavelengths. ✓✓ (2)
- 10.2.2 Decrease ✓ (1)
- [13]

QUESTION 11

- 11.1 An apparent change in observed/detected frequency/pitch/wavelength ✓ as a result of the relative motion between a source and an observer/listener. ✓ (2)
- 11.2.1 170 Hz ✓ (1)
- 11.2.2 130 Hz ✓ (1)

11.3 **POSITIVE MARKING FROM QUESTIONS 11.2.1 and 11.2.2.**

$$f_L = \frac{v \pm v_L}{v \pm v_s} f_s \checkmark$$

$$170 = \frac{(340+0)}{(340-v_s)} \times f_s \text{ ----- } \textcircled{1}$$

$$130 = \frac{(340-0)}{(340+v_s)} \times f_s \text{ ----- } \textcircled{2}$$

$$v_s = 45,33 \text{ m}\cdot\text{s}^{-1} \checkmark \quad (45,33 - 45,45 \text{ m}\cdot\text{s}^{-1})$$

(6)
[10]

QUESTION 12

12.1 An apparent change in observed/detected frequency/pitch/wavelength ✓ as a result of the relative motion between a source and an observer/listener. ✓ (2)

12.2 Towards A ✓ Recorded frequency higher. ✓ (2)

12.3

$f_L = \frac{v \pm v_L}{v \pm v_s} f_s \checkmark$	
<p>FOR A:</p> $690 = \frac{340}{340 - v_s} f_s \quad (1)$ $\frac{690}{610} = \frac{340 + v_s}{340 - v_s}$ $1,131 (340 - v_s) = 340 + v_s$ $v_s = 20,90 \text{ m}\cdot\text{s}^{-1} \checkmark (20,90 \text{ to } 20,92 \text{ m}\cdot\text{s}^{-1})$	<p>FOR B:</p> $610 = \frac{340}{340 + v_s} f_s \quad (2)$

(6)

12.4 Doppler flow meter ✓ **OR** Measuring foetal heartbeat **OR** Ultra sound **OR** Sonar **OR** Radar (for speeding) (1)

[11]

QUESTION 13

13.1 An apparent change in observed/detected frequency/pitch/wavelength ✓ as a result of the relative motion between a source and an observer/listener. ✓ (2)

13.2

<p>OPTION 1</p> $f_L = \frac{v \pm v_L}{v \pm v_s} f_s \checkmark \text{ OR } f_L = \frac{v}{v - v_s} f_s$ $(5100) = \frac{340}{(340 - 240)} f_s$ $f_s = 1\,500 \text{ Hz}$ $v = f\lambda \checkmark \therefore 340 = (1\,500)\lambda \checkmark \therefore \lambda = 0,23 \text{ m} \checkmark$	<p>OPTION 2</p> $f_L = \frac{v \pm v_L}{v \pm v_s} f_s \checkmark \text{ OR } f_L = \frac{v}{v - v_s} \left(\frac{v}{\lambda_s} \right)$ $(5100) = \left(\frac{340}{340 - 240} \right) \left(\frac{340}{\lambda_s} \right) \checkmark \checkmark$ $\lambda = 0,23 \text{ m} \checkmark$
---	---

(7)

13.3 Greater than ✓ (1)

[10]

QUESTION 14

14.1 An apparent change in observed/detected frequency/pitch/wavelength ✓ as a result of the relative motion between a source and an observer/listener. ✓ (2)

14.2 Away from ✓ Observed frequency lower ✓ (2)

14.3 $v = f\lambda \checkmark \therefore 340 = f(0,34) \checkmark \therefore f = 1\,000 \text{ Hz} \checkmark$ (3)

14.4 **POSITIVE MARKING FROM Q14.2.**

<p>OPTION 1</p> $f_L = \frac{v \pm v_L}{v \pm v_s} f_s \checkmark \text{ OR } f_L = \frac{v}{v - v_s} f_s$ $950 = \frac{340 - v_L}{340 + 0} (1\,000) \checkmark \therefore v_L = 17 \text{ m}\cdot\text{s}^{-1}$ $\text{Distance } x = v\Delta t = (17)(10) \checkmark = 170 \text{ m} \checkmark$	<p>OPTION 2</p> $f_L = \frac{v \pm v_L}{v \pm v_s} f_s \checkmark \text{ OR } f_L = \frac{v}{v - v_s} \left(\frac{v}{\lambda_s} \right)$ $950 = \frac{340 - v_L}{340 + 0} (1\,000) \checkmark$ $\text{Distance } x = 170 \text{ m} \checkmark$
---	--

(6)
[13]

ELECTROSTATICS

QUESTION 1

1.1 To ensure that charge does not leak to the ground/is insulated. ✓ (1)

1.2 Net charge = $\frac{Q_R + Q_S}{2} = \frac{+8 + (-4)}{2} \checkmark = 2 \mu\text{C} \checkmark$ (2)

1.3 **POSITIVE MARKING FROM QUESTION 1.2.**

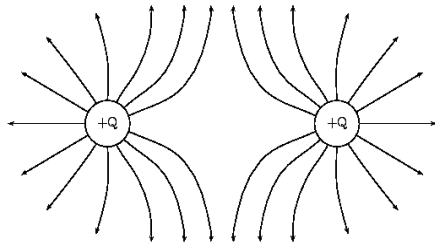

Criteria for sketch:	
Correct direction of field lines	✓
Shape of the electric field	✓
No field line crossing each other / No field lines inside the spheres.	✓

1.4 (2)

1.5 **POSITIVE MARKING FROM QUESTION 1.2.**

$$F = k \frac{Q_1 Q_2}{r^2} \checkmark$$

$$F_{ST} = \frac{(9 \times 10^9)(1 \times 10^{-6})(2 \times 10^{-6})}{(0,2)^2} \checkmark = 0,45 \text{ N left} \quad \text{OR} \quad F_{TS} = \frac{1}{4} F_{RT} = \frac{1}{4} (1,8) = 0,45 \text{ N left}$$

$$F_{RT} = \frac{(9 \times 10^9)(1 \times 10^{-6})(2 \times 10^{-6})}{(0,1)^2} \checkmark = 1,8 \text{ N right} \quad \text{OR} \quad F_{RT} = 4F_{ST} = 4(0,45) = 1,8 \text{ N right regs}$$

$$F_{\text{net}} = F_{ST} + F_{RT} = 1,8 + (-0,45) \checkmark = 1,35 \text{ N or towards sphere S or right S} \checkmark$$

1.6 Force experienced ✓ per unit positive charge ✓ placed at that point. (2)

1.7 **POSITIVE MARKING FROM QUESTION 1.5.**

OPTION 1

$$E = \frac{F}{q} \checkmark = \frac{1,35}{1 \times 10^{-6}} = 1,35 \times 10^6 \text{ N} \cdot \text{C}^{-1} \checkmark$$

OPTION 2

$$E_R = \frac{kQ}{r^2} \checkmark = \frac{(9 \times 10^9)(2 \times 10^{-6})}{(0,1)^2} \checkmark = 1,8 \times 10^6 \text{ N} \cdot \text{C}^{-1} \text{ right}$$

$$E_S = \frac{kQ}{r^2} = \frac{(9 \times 10^9)(2 \times 10^{-6})}{(0,2)^2} = 4,5 \times 10^5 \text{ N} \cdot \text{C}^{-1} \text{ left}$$

$$E_{\text{net}} = 1,8 \times 10^6 - 4,5 \times 10^5 = 1,35 \times 10^6 \text{ N} \cdot \text{C}^{-1} \checkmark$$

(3)
[19]

QUESTION 2

2.1 The (magnitude of the) electrostatic force exerted by one point charge on another point charge is directly proportional to the product of the (magnitudes of the) charges ✓ and inversely proportional to the square of the distance between them. ✓ (2)

2.2.1 $F = \frac{kQ_1 Q_2}{r^2}$ ✓
 $1,44 \times 10^{-1} = \frac{(9 \times 10^9) Q^2}{(0,5)^2} \checkmark$
 $Q = 2 \times 10^{-6} \text{ C} \checkmark$ (4)

2.2.2 **POSITIVE MARKING FROM QUESTION 2.2.1.**

$$Q = ne \checkmark$$

$$\frac{2 \times 10^{-6}}{1,6 \times 10^{-19}} = n \checkmark$$

$$n = 1,25 \times 10^{13} \text{ electrons/elektrone} \checkmark$$

(3)

- 2.3.1 Left / West ✓ (1)
- 2.3.2 Take right as positive/Neem regs as positief
 $E_{\text{net}} = E_A + E_B$ ✓
 $(3 \times 10^4) = -\frac{(9 \times 10^9)(2 \times 10^{-6})}{(1,5)^2} + \frac{(9 \times 10^9)Q_{\text{final}}}{(1)^2}$ ✓
 $Q_{\text{final}} = 4,22 \times 10^{-6} \text{ C}$ ✓
 $Q = ne$ ✓
 $4,22 \times 10^{-6} = n(1,6 \times 10^{-19})$ ✓
 $n_f = 2,64 \times 10^{13} \text{ electrons/elektrone}$ ✓
 electrons removed/elektrone verwyder
 $= (2,64 \times 10^{13} + 1,25 \times 10^{13})$ ✓
 $= 3,89 \times 10^{13} \text{ electrons/elektrone}$ ✓ (8)

[18]

QUESTION 3

- 3.1 The (magnitude of the) electrostatic force exerted by one point charge on another point charge is directly proportional to the product of the (magnitudes of the) charges ✓ and inversely proportional to the square of the distance between them. ✓ (2)
- 3.2 $F = k \frac{Q_1 Q_2}{r^2}$ ✓
 $F_{31} = \frac{(9 \times 10^9)(5 \times 10^{-6})(6 \times 10^{-6})}{(0,3)^2}$ ✓ = 3 N to the left
 $F_{32} = \frac{(9 \times 10^9)(5 \times 10^{-6})(3 \times 10^{-6})}{(0,1)^2}$ ✓ = 13,5 N downwards
 $F_R = F_{31} + F_{32} \therefore F_R = \sqrt{(3)^2 + (13,5)^2}$ ✓ = 13,83 N
 $\theta = \tan^{-1} \frac{13,5}{3}$ ✓ = 77,47°
 OR $\theta = \tan^{-1} \frac{3}{13,5}$ ✓ = 12,53° \therefore Net force = 13,83 N in direction 192,53° / 77,47° ✓ (7)
- Can use any trigonometric ratio
- [9]

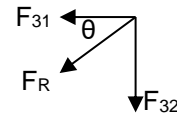
**QUESTION 4**

- 4.1 For object N: $n = \frac{Q}{q_e}$ ✓ $\therefore Q = (5 \times 10^6)(-1,6 \times 10^{-19})$ ✓ = $-8 \times 10^{-13} \text{ C}$ ✓ (3)
- 4.2 **POSITIVE MARKING FROM 4.1.**
 Charge on M (Q_M) is $+8 \times 10^{-13} \text{ C}$ ✓✓ (2)
- 4.3 The electric field at a point is the (electrostatic) force experienced per unit positive charge placed at that point. ✓✓ (2)
- 4.4 **POSITIVE MARKING FROM QUESTION 4.1 AND QUESTION 4.2.**
 $E = \frac{kQ}{r^2}$ ✓
 $E_{PM} = \frac{(9 \times 10^9)(8 \times 10^{-13})}{(0,25)^2}$ ✓ = $0,12 \text{ N} \cdot \text{C}^{-1}$ to the right
 $E_{PN} = \frac{(9 \times 10^9)(8 \times 10^{-13})}{(0,1)^2}$ ✓ = $0,72 \text{ N} \cdot \text{C}^{-1}$ to the left
 $E_{\text{net}} = E_{PM} - E_{PN}$ ✓ = $0,12 - 0,72 = -0,60 \text{ N} \cdot \text{C}^{-1}$ $\therefore E_{\text{net}} = \underline{0,60 \text{ N} \cdot \text{C}^{-1}}$ to the left ✓ (6)

[13]

QUESTION 5

- 5.1 $n = \frac{Q}{e}$ ✓ $\therefore n = \frac{0,5 \times 10^{-6}}{1,6 \times 10^{-19}}$ ✓ = $3,13 \times 10^{12} \text{ elektrone}$ ✓ (3)

5.2

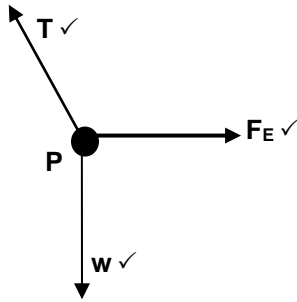

Accepted labels	
w	F _g / F _w / weight / mg / gravitational force
T	F _T / tension
F _E	Electrostatic force / F _C / Coulombic force / F _Q / F _{RP/PR}

(3)

5.3

The (magnitude) of the electrostatic force exerted by one point charge on another point charge is directly proportional to the product (of the magnitudes) of the charges ✓ and inversely proportional to the square of the distance between them. ✓

(2)

5.4

$$F_E = k \frac{Q_1 Q_2}{r^2} \checkmark$$

$$\frac{T \sin \theta}{T \cos \theta} = F_E$$

$$\therefore \frac{T \sin 7^\circ}{T \cos 83^\circ} \checkmark = \frac{(9 \times 10^9)(0,5 \times 10^{-6})(0,9 \times 10^{-6})}{(0,2)^2 \checkmark} \therefore T = 0,83 \text{ N} \checkmark$$

(5)
[13]

QUESTION 6

6.1

$$E_x = E_2 + E_{(-8)} \checkmark = \frac{kQ_2}{r^2} + \frac{kQ_{-8}}{r^2} \checkmark \text{ correct equation}$$

$$= \frac{(9 \times 10^9)(2 \times 10^{-5})}{(0,25)^2} \checkmark + \frac{(9 \times 10^9)(8 \times 10^{-6})}{(0,15)^2} \checkmark$$

$$= 2,88 \times 10^6 + 3,2 \times 10^6 = 6,08 \times 10^6 \text{ N} \cdot \text{C}^{-1} \checkmark \text{ to the east/right} \checkmark$$

OR

$$E = \frac{kQ}{r^2} \checkmark$$

$$E_2 = \frac{(9 \times 10^9)(2 \times 10^{-5})}{(0,25)^2} \checkmark = 2,88 \times 10^6 \text{ NC}^{-1} \text{ to the east/right}$$

$$E_{-8} = \frac{(9 \times 10^9)(8 \times 10^{-6})}{(0,15)^2} \checkmark = 3,2 \times 10^6 \text{ N} \cdot \text{C}^{-1} \text{ to the east/right}$$

$$E_x = E_2 + E_{(-8)} = (2,88 \times 10^6 + 3,2 \times 10^6) \checkmark = 6,08 \times 10^6 \text{ N} \cdot \text{C}^{-1} \checkmark \text{ to the east/right} \checkmark$$

(6)

6.2

POSITIVE MARKING FROM QUESTION 6.2.

<p>OPTION 1</p> $F_E = QE \checkmark$ $= (-2 \times 10^{-9})(6,08 \times 10^6) \checkmark$ $= -12,16 \times 10^{-3} \text{ N}$ $F_E = 1,22 \times 10^{-2} \text{ N} \checkmark \text{ to the west/left} \checkmark$	<p>OPTION 2</p> $F_{(-2)Q1} = qE_{(2)} \checkmark$ $= (2 \times 10^{-9})(2,88 \times 10^6)$ $= 5,76 \times 10^{-3} \text{ N to the west/left}$ $F_{(-2)Q2} = qE_{(8)}$ $= (2 \times 10^{-9})(3,2 \times 10^6)$ $= 6,4 \times 10^{-3} \text{ N to the west/left}$ $F_{\text{net}} = 5,76 \times 10^{-3} + 6,4 \times 10^{-3} \checkmark$ $= 1,22 \times 10^{-2} \text{ N} \checkmark \text{ to the west/left}$
--	--

(4)

6.3

POSITIVE MARKING FROM QUESTION 6.2.
 $2,44 \times 10^{-2} \text{ N} \checkmark$ / twice / double

(1)
[11]

QUESTION 7

7.1

The magnitude of the charges is equal. ✓

(1)

7.2

The (magnitude) of the electrostatic force exerted by one point charge on another point charge is directly proportional to the product (of the magnitudes) of the charges ✓ and inversely proportional to the square of the distance between them. ✓

(2)

7.3.1 $T \cos 20^\circ = w \checkmark$
 $= mg$
 $= (0,1)(9,8) \checkmark = 0,98 \text{ N}$

$\therefore T = 1,04 \text{ N} \checkmark$

(3)

7.3.2 **POSITIVE MARKING FROM QUESTION 7.3.1.**

$F_{\text{electrostatic/elektrostaties}} = T \sin 20^\circ \checkmark$

$\frac{kQ_1 Q_2}{r^2} \checkmark = (1,04) \sin 20^\circ$

$\frac{kQ_1 Q_2}{r^2} = 0,356$

$\frac{(9 \times 10^9)(250 \times 10^{-9})(250 \times 10^{-9})}{r^2} \checkmark = 0,356 \checkmark$

$\therefore r = 0,0397 \text{ m} \checkmark$

(5)
[11]

QUESTION 8

8.1

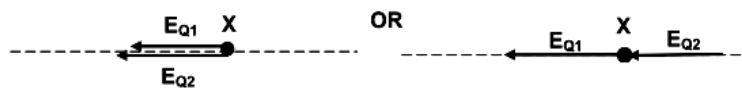

Vectors E_{Q1} and E_{Q2} in the same direction. $\checkmark \checkmark$

Correct drawing of vectors E_{Q1} and E_{Q2} . $\checkmark \checkmark$ The fields due to the two charges add up because they come from the same direction. Hence the field cannot be zero.

(4)

8.2

$E = k \frac{Q}{r^2} \checkmark$

$E_{-2,5\mu\text{C}} = k \frac{Q}{r^2} = \frac{(9 \times 10^9)(2,5 \times 10^{-6})}{(0,3)^2} \checkmark = 250\,000 \text{ N.C}^{-1} \text{ to the left/na links}$

$E_{6\mu\text{C}} = k \frac{Q}{r^2} = \frac{(9 \times 10^9)(6 \times 10^{-6})}{(1,3)^2} \checkmark = 31\,952,66 \text{ N.C}^{-1} \text{ to the left/na links}$

$E_P = E_{6\mu\text{C}} + E_{-2,5\mu\text{C}} \checkmark$

$= 31\,952,66 + 250\,000$

$= 281\,952,66 \text{ N.C}^{-1} \checkmark \text{ to the left/na links} \checkmark$

(6)
[10]

QUESTION 9

9.1

$n = \frac{Q}{e} \checkmark = \frac{-32 \times 10^{-9}}{-1,6 \times 10^{-19}} \checkmark$ $= 2 \times 10^{11} \checkmark \text{ electrons}$	$n = \frac{Q}{e} \checkmark = \frac{32 \times 10^{-9}}{1,6 \times 10^{-19}} \checkmark$ $= 2 \times 10^{11} \checkmark \text{ electrons}$
--	--

(3)

9.2

OR

Accepted labels	
w	$F_g/F_w/\text{weight}/mg/\text{gravitational force}$
T	$F_T/\text{tension}$
F_E	$F_{\text{electrostatic}}/F_{Q_1Q_2}/\text{Coulomb force}/F$

(3)

9.3

$F_{\text{net}} = mg + F_E - T = 0 \therefore mg + k \frac{Q_1 Q_2}{r^2} - T = 0 \checkmark$

$\therefore (0,007)(9,8) \checkmark + (9 \times 10^9) \frac{(32 \times 10^{-9})(55 \times 10^{-9})}{(0,025)^2} \checkmark = T \quad \therefore T = 9,39(4) \times 10^{-2} \text{ N} \checkmark$

(5)
[11]

QUESTION 10

10.1

The (electrostatic) force experienced by a unit positive charge (placed at that point). $\checkmark \checkmark$

(2)

10.2

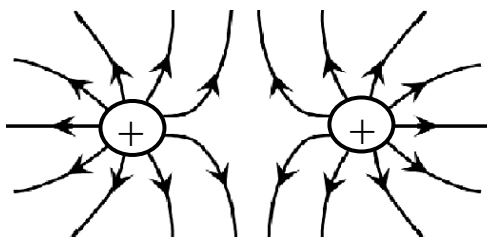

Marking guidelines	
Lines must not cross / Lines must touch the spheres but not enter spheres	\checkmark
Arrows point outwards	\checkmark
Correct shape	\checkmark

(3)

10.3

$$E = \frac{kQ}{r^2} \checkmark$$

$$E_{Q1X} = \frac{(9 \times 10^9)(30 \times 10^{-6})}{(x)^2} \checkmark \quad \& \quad E_{Q2X} = \frac{(9 \times 10^9)(45 \times 10^{-6})}{(0,15 + x)^2} \checkmark$$

$$E_{\text{net}} = 0 \quad \therefore E_{Q1X} = E_{Q2X} \quad \therefore \frac{(9 \times 10^9)(30 \times 10^{-6})}{(x)^2} = \frac{(9 \times 10^9)(45 \times 10^{-6})}{(0,15 + x)^2} \checkmark$$

$$\therefore x = 0,67 \text{ m} \checkmark \quad (0,667 \text{ m})$$

(5)
[10]**QUESTION 11**

11.1.1 The magnitude of the electrostatic force exerted by one point charge on another point charge is directly proportional to the product of the (magnitudes of the) charges \checkmark and inversely proportional to the square of the distance between them. \checkmark (2)

11.1.2 F_E /Electrostatic force \checkmark (1)

11.1.3 The electrostatic force is inversely proportional to the square of the distance between the charges. \checkmark (1)

11.1.4

$$\text{Slope} = \frac{\Delta F_E}{\Delta \frac{1}{r^2}} \checkmark = \frac{0,027 - 0}{5,6 - 0} \checkmark = 4,82 \times 10^{-3} \text{ N}\cdot\text{m}^2$$

$$\text{Slope} = F_E r^2 = kQ_1 Q_2 = kQ^2 \checkmark \quad \therefore 4,82 \times 10^{-3} \checkmark = \underline{9 \times 10^9 Q^2} \checkmark \quad \therefore Q = 7,32 \times 10^{-7} \text{ C} \checkmark \quad (6)$$

11.2.1

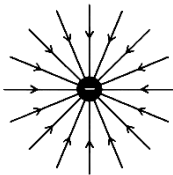

Criteria for drawing electric field:	
Direction	\checkmark
Field lines radially inward	\checkmark

(2)

11.2.2

$$E = \frac{kQ}{r^2} \checkmark$$

Right as positive:

$$E_{PA} = \frac{(9 \times 10^9)(0,75 \times 10^{-6})}{(0,09)^2} \checkmark = 8,33 \times 10^5 \text{ N}\cdot\text{C}^{-1} \text{ to the left}$$

$$E_{PB} = \frac{(9 \times 10^9)(0,8 \times 10^{-6})}{(0,03)^2} \checkmark = 8 \times 10^6 \text{ N}\cdot\text{C}^{-1} \text{ to the left}$$

$$E_{\text{net}} = E_{PA} + E_{PC} = [-8,33 \times 10^5 + (-8 \times 10^6)] \checkmark \checkmark = -8,83 \times 10^6 = 8,83 \times 10^6 \text{ N}\cdot\text{C}^{-1} \checkmark$$

$$\text{Left as positive: } E_{\text{net}} = E_{PA} + E_{PC} = \underline{(8,33 \times 10^5 + 8 \times 10^6)} \checkmark \checkmark = 8,83 \times 10^6 \text{ N}\cdot\text{C}^{-1} \checkmark$$

(5)
[17]**QUESTION 12**

12.1 The magnitude of the electrostatic force exerted by one point charge on another point charge is directly proportional to the product of the (magnitudes of the) charges \checkmark and inversely proportional to the square of the distance between them. \checkmark (2)

12.2.1 Negative $\checkmark \checkmark$ (2)

12.2.2

$$F = k \frac{Q_1 Q_3}{r^2} \checkmark$$

$$0,012 = \frac{(9 \times 10^9) Q_1 (2 \times 10^{-6})}{(2,5)^2} \checkmark \quad \therefore Q_1 = 4,17 \times 10^{-6} \text{ C} \checkmark$$

$$F_{\text{net}} = F_{Q13} + F_{Q23} \checkmark$$

$$-0,3 \checkmark = 0,012 - \frac{(9 \times 10^9)(Q_2)(2 \times 10^{-6})}{1^2} \checkmark \quad \text{OR} \quad 0,3 = -0,012 + \frac{(9 \times 10^9)(Q_2)(2 \times 10^{-6})}{1^2}$$

$$\therefore Q_2 = 1,6 \times 10^{-5} \text{ C} \checkmark$$

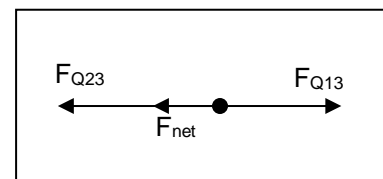
(7)
[11]

QUESTION 13

13.1 Electric field is a region of space in which an electric charge experiences a force. ✓✓ (2)

13.2

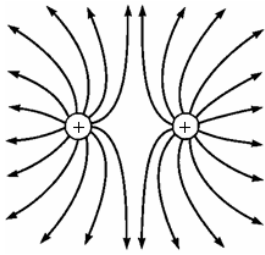

Criteria for sketch	
Correct shape as shown.	✓
Direction away from positive	✓
Field lines start on spheres and do not cross.	✓

(3)

$$13.3 \quad E_{PA} = \frac{kQ}{r^2} \checkmark = \frac{(9 \times 10^9)(5 \times 10^{-6})}{(1,25)^2} \checkmark = 2,88 \times 10^4 \text{ N} \cdot \text{C}^{-1} \text{ to the right}$$

$$E_{PB} = \frac{kQ}{r^2} = \frac{(9 \times 10^9)(5 \times 10^{-6})}{(0,75)^2} \checkmark = 8,00 \times 10^4 \text{ N} \cdot \text{C}^{-1} \text{ to the left}$$

$$E_{\text{net}} = E_{PA} + E_{PB} = 2,88 \times 10^4 + (-8,00 \times 10^4) = 5,12 \times 10^4 \text{ N} \cdot \text{C}^{-1} \checkmark$$

(5)
[10]

QUESTION 14

14.1.1 Removed ✓ (1)

$$14.1.2 \quad n = \frac{Q}{e} \checkmark = \frac{6 \times 10^{-6}}{1,6 \times 10^{-19}} \checkmark = 3,75 \times 10^{13} \checkmark \text{ electrons} \quad (3)$$

14.2.1 Negative ✓ (1)

14.2.2

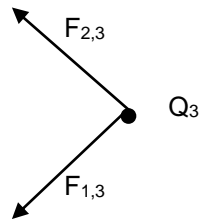

(2)

14.2.3

$$F = \frac{kQ_1Q_2}{r^2} \checkmark$$

$$F_{1,3x} = \frac{(9 \times 10^9)(2 \times 10^{-6})(6 \times 10^{-6})}{r^2} (\cos 45^\circ) \checkmark = \frac{0,0764}{r^2} \checkmark$$

(3)

14.2.4 **POSITIVE MARKING FROM QUESTION 14.2.3.**

$$F = \frac{kQ_1Q_2}{r^2}$$

$$F_{2,3x} = \frac{(9 \times 10^9)(2 \times 10^{-6})(6 \times 10^{-6})}{r^2} (\cos 45^\circ) \checkmark = \frac{0,0764}{r^2}$$

$$F_x = F_{1,3x} + F_{2,3x}$$

$$F_x = \frac{0,0764}{r^2} + \frac{0,0764}{r^2} = 2 \frac{0,0764}{r^2} \checkmark \text{ Addition}$$

$$(0,12) \checkmark = \frac{0,1528}{r^2} \therefore r = 1,128 \text{ m} \checkmark$$

NOTE: $F_{y \text{ net}} = 0$

(4)

14.3.1 The electric field at a point is the (electrostatic) force experienced ✓ per unit positive charge ✓ placed at that point. (2)

14.3.2

$$E = \frac{kQ}{r^2} \checkmark \therefore 100 = \frac{(9 \times 10^9)Q}{(0,6)^2} \checkmark \therefore Q = 4 \times 10^{-9} \text{ C}$$

When the electric field strength 50 is $\text{N} \cdot \text{C}^{-1}$:

$$E = \frac{kQ}{r^2} \therefore 50 = \frac{(9 \times 10^9)(4 \times 10^{-9})}{r^2} \checkmark \text{ equation}$$

$$\therefore r = 0,85 \text{ m} \checkmark (0,845) \text{ m}$$

(5)
[21]

QUESTION 15

15.1 The magnitude of the electrostatic force exerted by one point charge on another point charge is directly proportional to the product of the (magnitudes of the) charges ✓ and inversely proportional to the square of the distance between them. ✓ (2)

15.2

<p>OPTION 1</p> $F = \frac{kQ_1Q_2}{r^2} \checkmark = \frac{(9 \times 10^9)(6 \times 10^{-6})(8 \times 10^{-6})}{(0,2)^2} \checkmark = 10,8 \text{ N} \checkmark$
<p>OPTION 2</p> <p>Both ✓ $\left\{ \begin{array}{l} E = \frac{kQ}{r^2} = \frac{(9 \times 10^9)(8 \times 10^{-6})}{(0,2)^2} \checkmark = 1,8 \times 10^4 \text{ N} \cdot \text{C}^{-1} \\ F = Eq = (1,8 \times 10^4)(6 \times 10^{-6}) \checkmark = 10,8 \text{ N} \checkmark \end{array} \right.$</p>

15.3

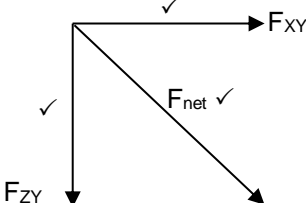

Marking criteria	
F _{Z op Y} if correct direction	✓
F _{X op Y} if correct direction	✓
Resultant vector	✓

15.4 **POSITIVE MARKING FROM QUESTION 15.2.**

<p>OPTION 1</p> $F_{\text{net}}^2 = F_{XY}^2 + F_{ZY}^2 \quad \left. \vphantom{F_{\text{net}}^2} \right\} \checkmark \text{ Any one}$ $15,20^2 = 10,8^2 + F_{ZY}^2$ $F_{ZY} = 10,696 \text{ N}$ $F_{ZY} = k \frac{Q_Z Q_Y}{r^2} \therefore 10,696 \checkmark = 9 \times 10^9 \times \frac{8 \times 10^{-6} \times Q_Z}{(0,30)^2} \checkmark \therefore Q_Z = 1,34 \times 10^{-5} \text{ C} \checkmark$
<p>OPTION 2</p> $\cos \theta = \frac{10,8}{15,2} \therefore \theta = 44,72^\circ$ $\sin 44,72 = \frac{F_{ZY}}{15,2} \checkmark \quad \text{OR} \quad \tan 44,72 = \frac{F_{ZY}}{F_{XY}}$ $\therefore F_{ZY} = 10,696 \text{ N}$ $F_{ZY} = k \frac{Q_Z Q_Y}{r^2}$ $\therefore 10,696 \checkmark = 9 \times 10^9 \times \frac{8 \times 10^{-6} \times Q_Z}{(0,30)^2} \checkmark$ $\therefore Q_Z = 1,34 \times 10^{-5} \text{ C} \checkmark$

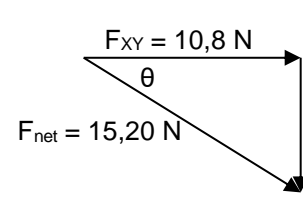

QUESTION 16

16.1 Electric field at a point is the force per unit positive charge placed at that point. ✓✓ (2)

16.2

$$E = \frac{kQ}{r^2} \checkmark$$

$$E_{\text{net}} = (E_A + E_B)$$

$$= 9 \times 10^9 \frac{(1,5 \times 10^{-6})}{(0,4)^2} \checkmark + 9 \times 10^9 \frac{(2,0 \times 10^{-6})}{(0,3)^2} \checkmark$$

$$= 2,84 \times 10^5 \text{ N} \cdot \text{C}^{-1} \checkmark$$

16.3 **POSITIVE MARKING FROM QUESTION 16.2.**

$$F_E = qE \checkmark$$

$$= (3,0 \times 10^{-9})(2,84 \times 10^5) \checkmark$$

$$= 8,52 \times 10^{-4} \text{ N} \checkmark$$

QUESTION 17

17.1 The magnitude of the electrostatic force exerted by one point charge on another point charge is directly proportional to the product of the (magnitudes of the) charges ✓ and inversely proportional to the square of the distance between them. ✓ (2)

17.2  (2)

17.3 To the right as positive:

$$F = k \frac{Q_1 Q_2}{r^2} \quad \checkmark$$

$$F_{\text{netR}} = F_{\text{PR}} + F_{\text{SR}}$$

$$F_{\text{net}} = \frac{kQ_1 Q_2}{r^2} + \frac{kQ_1 Q_2}{r^2}$$

$$-1,27 \times 10^{-6} = \left\{ \frac{(9 \times 10^9)(1,5 \times 10^{-9})(Q)}{(0,3)^2} - \frac{(9 \times 10^9)(2 \times 10^{-9})(Q)}{(0,2)^2} \right\}$$

$$-1,27 \times 10^{-6} = 150Q - 450Q \quad \checkmark \quad \therefore 4,23 \times 10^{-9} \text{ C} \quad \checkmark$$

(7)
[11]

QUESTION 18

18.1

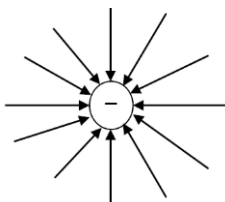

Marking criteria:

Shape (radial) ✓

Polarity of A ✓

(2)

18.2

$$E = \frac{kQ}{r^2} \quad \checkmark$$

$$3 \times 10^7 = \frac{(9 \times 10^9)(Q)}{(0,5)^2} \quad \checkmark$$

$$Q = 8,33 \times 10^{-4} \text{ C} \quad \checkmark$$

(3)

18.3

$$Q = ne \quad \checkmark$$

$$= (10^5)(1,6 \times 10^{-19}) \quad \checkmark$$

$$= 1,6 \times 10^{-14} \text{ C}$$

$$E = \frac{F}{Q} \quad \checkmark$$

$$3 \times 10^7 = \frac{F}{1,6 \times 10^{-14}} \quad \checkmark$$

$$F = 4,8 \times 10^{-7} \text{ N} \quad \checkmark \text{ Right/Regs} \quad \checkmark$$

Positive marking from Q8.2 for this option.

$$F = k \frac{Q_1 Q_2}{r^2} \quad \checkmark$$

$$F = (9 \times 10^9) \frac{(8,33 \times 10^{-4})(1,6 \times 10^{-14})}{(0,5)^2} \quad \checkmark$$

$$= 4,8 \times 10^{-7} \text{ N} \quad \checkmark \text{ Right/Regs} \quad \checkmark$$

(6)

[11]

QUESTION 19

19.1 The two forces must be equal in magnitude ✓ but in opposite directions. ✓ (2)

19.2 The magnitude of the electrostatic force exerted by one point charge on another point charge is directly proportional to the product of the (magnitudes of the) charges ✓ and inversely proportional to the square of the distance between them. ✓ (2)

19.3 **OPTION 1**

$$F = k \frac{Q_1 Q_2}{r^2} \quad \checkmark$$

$$F_{\text{PQ}} = \frac{(9 \times 10^9)(Q)(5 \times 10^{-6})}{(x)^2} \quad \checkmark = \frac{45 \times 10^3 Q}{x^2}$$

$$F_{\text{VQ}} = \frac{(9 \times 10^9)(Q)(7 \times 10^{-6})}{(1-x)^2} \quad \checkmark = \frac{63 \times 10^3 Q}{(1-x)^2}$$

$$(F_{\text{net}} = F_{\text{PQ}} - F_{\text{VQ}} = 0)$$

$$\frac{45 \times 10^3 Q}{x^2} = \frac{63 \times 10^3 Q}{(1-x)^2} \quad \checkmark \quad \therefore 6,708(1-x) = 7,937x \quad \therefore x = 0,46 \text{ m away from P}$$

(5)
[9]

QUESTION 20

20.1

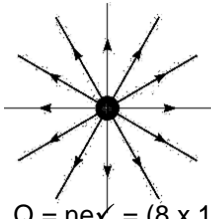

Criteria for sketch	
Lines are directed away from the charge.	✓
Lines are radial, start on sphere and do not cross.	✓

(2)

20.2

$$Q = ne \checkmark = (8 \times 10^{13})(-1,6 \times 10^{-19}) \checkmark \text{ or } (8 \times 10^{13})(1,6 \times 10^{-19})$$

$$= -12,8 \times 10^{-6} \text{ C}$$

Net charge on the sphere $Q_{\text{net}} = (+ 6 \times 10^{-6}) + (-12,8 \times 10^{-6}) \checkmark = - 6,8 \times 10^{-6} \text{ C}$

$$E = \frac{kQ}{r^2} \checkmark$$

$$E = \frac{(9 \times 10^9)(6,8 \times 10^{-6})}{(0,5)^2} \checkmark$$

$$= 2,45 \times 10^5 \text{ N} \cdot \text{C}^{-1} \checkmark \text{ towards sphere } \checkmark$$

(7)
[9]

QUESTION 21

21.1

$$Q_{\text{net}} = \frac{Q_1 + Q_2 + Q_3}{3} \therefore -3 \times 10^{-9} = \frac{-15 \times 10^{-9} + Q + 2 \times 10^{-9}}{3} \checkmark \therefore Q = + 4 \times 10^{-9} \text{ C } \checkmark$$

(2)

21.2

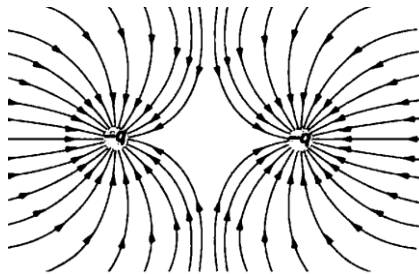

Correct shape ✓
Correct direction ✓
Lines must not cross and must touch spheres ✓

(3)

21.3

The magnitude of the electrostatic force exerted by one point charge on another point charge is directly proportional to the product of the (magnitudes) of the charges and inversely proportional to the square of the distance between them. ✓✓

(2)

21.4

OPTION 1	OPTION 2
$F = \frac{kQ_1 Q_2}{r^2} \checkmark$ $F_{\text{SP}} = \frac{(9 \times 10^9)(3 \times 10^{-9})(3 \times 10^{-9})}{(0,1)^2} \checkmark$ $= 8,1 \times 10^{-6} \text{ N downwards}$ $F_{\text{TP}} = \frac{(9 \times 10^9)(3 \times 10^{-9})(3 \times 10^{-9})}{(0,3)^2} \checkmark$ $= 9 \times 10^{-7} \text{ N left}$ $F_{\text{net}}^2 = (F_{\text{SP}})^2 + (F_{\text{TP}})^2$ $F_{\text{net}} = \sqrt{(F_{\text{SP}})^2 + (F_{\text{TP}})^2}$ $F_{\text{net}} = \sqrt{(8,1 \times 10^{-6})^2 + (0,9 \times 10^{-6})^2}$ $F_{\text{net}} = 8,15 \times 10^{-6} \text{ N } \checkmark$	$E_s = \frac{kQ}{r^2} = \frac{(9 \times 10^9)(3 \times 10^{-9})}{(0,1)^2}$ $= 2700 \text{ N} \cdot \text{C}^{-1}$ $E_T = \frac{kQ}{r^2} = \frac{(9 \times 10^9)(3 \times 10^{-9})}{(0,3)^2}$ $= 300 \text{ N} \cdot \text{C}^{-1}$ $E_{\text{net}} = \sqrt{E_s^2 + E_T^2} = \sqrt{(2700)^2 + (300)^2} \checkmark$ $= 2716,62 \text{ N} \cdot \text{C}^{-1}$ $F = Eq = (2716,62)(3 \times 10^{-9}) \checkmark$ $= 8,15 \times 10^{-6} \text{ N } \checkmark$

(5)

21.5 **POSITIVE MARKING FROM QUESTION 21.4.**

$$E = \frac{F}{q} \checkmark = \frac{8,15 \times 10^{-6}}{3 \times 10^{-9}} \checkmark$$

$$= 2,72 \times 10^3 \text{ N} \cdot \text{C}^{-1} \checkmark$$

(3)

21.6.1

Sphere P or T ✓

(1)

21.6.2

SPHERE P: $n_e = \frac{Q}{q_e}$ or $n_e = \frac{Q}{e} = \frac{-15 \times 10^{-9}}{-1,6 \times 10^{-19}} \checkmark = 9,38 \times 10^{10}$

mass gained = $n_e m_e = (9,38 \times 10^{10})(9,11 \times 10^{-31}) \checkmark = 8,55 \times 10^{-20} \text{ kg} \checkmark$

SPHERE T:

$n_e = \frac{Q}{q_e}$ or $n_e = \frac{Q}{e} = \frac{-5 \times 10^{-9}}{-1,6 \times 10^{-19}} \checkmark = 3,125 \times 10^{10}$

mass gained = $n_e m_e = (3,125 \times 10^{10})(9,11 \times 10^{-31}) \checkmark = 2,85 \times 10^{-20} \text{ kg} \checkmark$

(3)
[19]

ELECTRIC CIRCUITS

QUESTION 1

1.1.1 Keep the temperature (of battery) constant. \checkmark

(1)

1.1.2

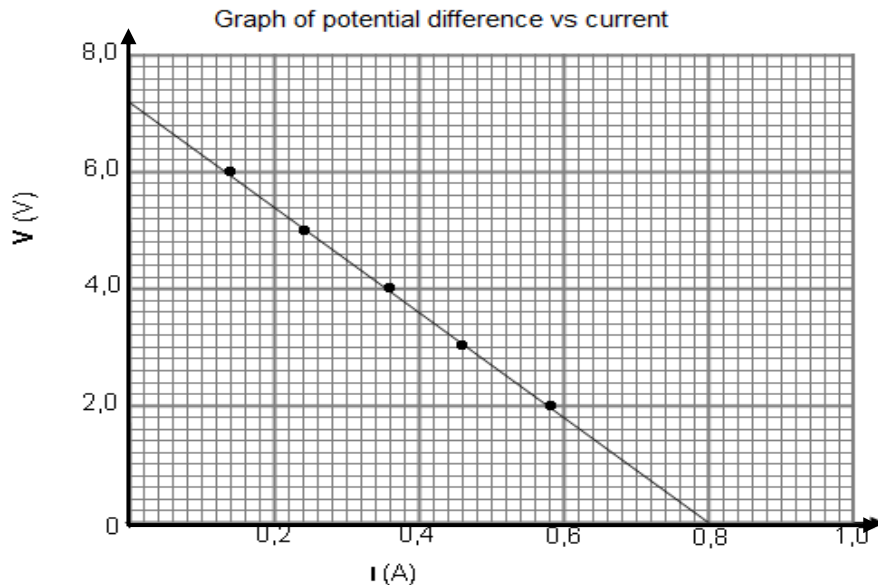

Criteria for drawing line of best fit:	
ALL points correctly plotted (at least 4 points)	$\checkmark\checkmark$
Correct line of best fit if 3 plotted points are used.	\checkmark

(3)

1.1.3 7,2 V \checkmark

(Accept any readings between 7,0 V and 7,4 V or the value of the y-intercept.)

(1)

1.1.4 **POSITIVE MARKING FROM QUESTION 1.1.3**

Slope = $\frac{\Delta V}{\Delta I} = \frac{0 - 7,2}{0,8 - 0} \checkmark = -9 \therefore r = 9 \Omega \checkmark$

(3)

1.2.1 $P = VI \checkmark \therefore 100 = 20(I) \checkmark \therefore I = 5 \text{ A} \checkmark$

(3)

1.2.2 $P = \frac{V^2}{R} \checkmark \therefore R = \frac{(20)^2}{150} \checkmark = 2,67 \Omega \checkmark$

(3)

1.2.3 **POSITIVE MARKING FROM QUESTION 1.2.2.**

$P = VI$ OR $P = I^2R$

$\therefore I_{150W} = \frac{150}{20} \checkmark = 7,5 \text{ A} \quad \therefore I_{150W} = \sqrt{\frac{150}{2,67}} \checkmark = 7,5 \text{ A}$

$I_{tot} = (5 + 7,5) \checkmark$

$\epsilon = I(R + r) \checkmark \therefore 24 = 12,5(R + r)$

$24 = V_{ext} + V_{ir} \therefore 24 = 20 + 12,5(r) \checkmark \therefore r = 0,32 \Omega \checkmark$

(5)

1.2.4 Device Z is a voltmeter. \checkmark

(1)

1.2.5 Device Z should be a voltmeter (or a device with very high resistance) because it has a very high resistance \checkmark and will draw very little current. \checkmark

The current through X and Y will remain the same hence the device can operate as rated.

(2)

[22]

QUESTION 2

2.1.1 Same length of wires. ✓
Same thickness/cross-sectional area of wires. ✓ (2)

2.1.2 Wire **A** (Resistor A)/Draad **A** ✓

$$R = \frac{\Delta V}{\Delta I} \checkmark$$

$$R_A = \frac{4,4}{0,4} \checkmark = 11 \Omega \checkmark$$

$$R_B = \frac{2,2}{0,4} \checkmark = 5,5 \Omega \checkmark$$

$$E = I^2 R \Delta t \checkmark$$

Accept any correct coordinates chosen from the graph
Aanvaar enige korrekte koördinate van die grafiek gekies.

For the same time and current, the heating in A will be higher because its resistance is higher than that of B. ✓ (8)

2.2.1

OPTION 1/OPSIE 1

$$I_{5,5\Omega} : I_{11\Omega}$$

$$2 : 1$$

$$I_{5,5\Omega} = (0,2)(2) \checkmark \checkmark$$

$$= 0,4 \text{ A} \checkmark$$

OPTION 2/OPSIE 2

$$V = IR$$

$$V_{11\Omega} = 0,2 \times 11$$

$$= 2,2 \text{ V} \checkmark$$

$$V_{5,5} = V_{11} = 2,2 \text{ V} \checkmark$$

$$I_{5,5} = \frac{2,2}{5,5}$$

$$= 0,4 \text{ A} \checkmark$$

(3)

2.2.2

OPTION 1/OPSIE 1

$$V = IR$$

$$I_{\text{tot}} = (0,4 + 0,2) \checkmark$$

$$= 0,6 \text{ A}$$

$$\frac{1}{R_p} = \frac{1}{R_1} + \frac{1}{R_2} + \dots \checkmark$$

$$\frac{1}{R_p} = \frac{1}{11} + \frac{1}{5,5} \checkmark$$

$$R_p = 3,67 \Omega$$

$$R_T = R_p + R_A$$

$$= 3,67 + 11 \checkmark$$

$$= 14,67 \Omega$$

$$\varepsilon = I(R + r) \checkmark$$

$$9 = 0,6(14,67 + r) \checkmark$$

$$r = 0,33 \Omega \checkmark$$

OPTION 2/OPSIE 2

$$I_{\text{tot}} = (0,4 + 0,2) \checkmark$$

$$= 0,6 \text{ A}$$

$$V_{\text{ext}} = V_{11\Omega} + V_{//} \checkmark$$

$$= [I_{\text{tot}}(R_{11}) + 2,2]$$

$$= 0,6(11) \checkmark + 2,2$$

$$= 8,8 \text{ V} \checkmark$$

$$\varepsilon = V_{\text{ext}} + I_{\text{tot}}(r) \checkmark$$

$$9 = 8,8 + 0,6r \checkmark$$

$$r = 0,33 \Omega \checkmark$$

(7)

2.2.3

Decrease ✓

The total resistance increases. ✓

(2)

[22]**QUESTION 3**

3.1 Negative ✓ (1)

3.2 $I_{2\Omega} = \frac{V}{R} \checkmark = \frac{1,36}{(4+2)} \checkmark = 0,23 \text{ A} \checkmark$ (3)

3.3 **POSITIVE MARKING FROM QUESTION 3.2**

OPTION 1

$$I_{3\Omega} = \frac{V}{R} = \frac{1,36}{3} \checkmark = 0,45 \text{ A}$$

$$I_T = I_2 + I_3 = 0,23 + 0,45 \checkmark = 0,68 \text{ A}$$

$$V_{\text{int}}^{\text{lost}} = \varepsilon - V_{\text{ext}} \checkmark = 1,5 - 1,36 \checkmark = 0,14 \text{ V}$$

$$V_{\text{int}}^{\text{lost}} = Ir \checkmark$$

$$0,14 = (0,68)r \checkmark \therefore r = 0,21 \Omega \checkmark$$

OPTION 2

$$I_3 = \frac{V}{R} = \frac{1,36}{3} \checkmark = 0,45 \text{ A}$$

$$I_T = I_2 + I_3 = 0,23 + 0,45 \checkmark = 0,68 \text{ A}$$

$$\frac{1}{R_p} = \frac{1}{R_1} + \frac{1}{R_2} \checkmark \therefore \frac{1}{R_p} = \frac{1}{6} + \frac{1}{3} \checkmark \therefore R_p = 2 \Omega$$

$$\varepsilon = I(R + r) \checkmark \therefore 1,5 = 0,68(2 + r) \checkmark \therefore r = 0,21 \Omega \checkmark$$

(7)

3.4 Decrease ✓ Effective resistance across parallel circuit decreases. ✓ Terminal potential difference decreases. ✓ Resistance in ammeter branch remains constant. ✓ (4)

[15]

QUESTION 4

4.1 The potential difference across a conductor is directly proportional to the current ✓ in the conductor at constant temperature. ✓ (2)

<p>OPTION 1 $V_8 = IR \checkmark = (0,5)(8) = 4 \text{ V} = V_{16}$ $I_{16} = \frac{V}{R} = \frac{4}{16} = 0,25 \text{ A}$ $I_{tot//} = I_{A1} = (0,5 + 0,25) \checkmark = 0,75 \text{ A} \checkmark$</p>	<p>OPTION 2 $V_8 = IR \checkmark = (0,5)(8) \checkmark = 4 \text{ V}$ $\frac{1}{R_p} = \frac{1}{R_1} + \frac{1}{R_2} = \frac{1}{8} + \frac{1}{16} \checkmark \therefore R = 5,33 \Omega$ $I_{tot//} = \frac{4}{5,33} = I_{A1} = 0,75 \text{ A} \checkmark$</p>
--	---

4.3 **POSITIVE MARKING FROM QUESTION 4.2.**

<p>OPTION 1 $V_{20\Omega} = IR = (0,75)(20) \checkmark = 15 \text{ V}$ $V_{//tot} = (15 + 4) \checkmark = 19 \text{ V}$ $V_R = 19 \text{ V}$ $P = VI \checkmark$ $\therefore 12 = (19)I_R \checkmark$ $\therefore I_R = I_{A2} = 0,63 \text{ A} \checkmark$</p>	<p>OPTION 2 $\frac{1}{R_p} = \frac{1}{R_1} + \frac{1}{R_2} = \frac{1}{8} + \frac{1}{16} \checkmark \therefore R = 5,33 \Omega$ $R_{//} + R_{20} = (5,33 + 20) \checkmark = 25,33 \Omega$ $V_{//tot} = I(R_{//} + R_{20}) = (0,75)(25,33) = 19 \text{ V}$ $P = VI \checkmark \therefore 12 = (19)I_R \checkmark$ $\therefore I_R = I_{A2} = 0,63 \text{ A} \checkmark$</p>
--	--

4.4 **POSITIVE MARKING FROM QUESTION 4.2 AND QUESTION 4.3.**

<p>OPTION 1 $\mathcal{E} = I(R + r) \checkmark = V_{//tot} + V_{int}$ $= 19 + (0,75 + 0,63)(1) \checkmark = 20,38 \text{ V} \checkmark$</p>	<p>OPTION 2 $V_{int} = Ir = (0,75 + 0,63)(1) \checkmark = 1,38 \text{ V}$ $\mathcal{E} = V_{//tot} + V_{int} \checkmark = 19 + 1,38 = 20,38 \text{ V} \checkmark$</p>
--	--

QUESTION 5

5.1.1 $V = IR \checkmark$
 $= (0,2)(4+8) \checkmark$
 $= 2,4 \text{ V} \checkmark$ (3)

<p>5.1.2 $V = IR$ $2,4 = I_2(2) \checkmark$ $I_{2\Omega} = 1,2 \text{ A} \checkmark$ $I_T = I_2 + 0,2 \text{ A} \checkmark$ $= 1,4 \text{ A} \checkmark$</p>	<p>OR $I_2 = 6 \times 0,2 \checkmark$ $I_2 = 1,2 \text{ A} \checkmark$ $I_T = I_2 + 0,2 \checkmark$ $= 1,4 \text{ A} \checkmark$</p>
---	---

<p>5.1.3 OPTION 1 $\frac{1}{R_p} = \frac{1}{R_1} + \frac{1}{R_2} \checkmark$ $\frac{1}{R_p} = \frac{1}{12} + \frac{1}{2}$ $R_p = 1,72 \Omega \checkmark$ $\mathcal{E} = I(R+r) \checkmark$ $= 1,4(1,72 + 0,5) \checkmark$ $= 3,11 \text{ V} \checkmark$</p>	<p>OPTION 2 $V_{int} = Ir \checkmark$ $= (1,4)(0,5)$ $= 0,7 \text{ V} \checkmark$ $\mathcal{E} = V_{ext/eks} + V_{int} \checkmark$ $= 2,4 + 0,7 \checkmark$ $= 3,1 \text{ V} \checkmark$</p>
--	---

5.2 Removing the 2 Ω resistor increases the total resistance of the circuit. ✓ Thus total current decreases, decreasing the V_{int} (V_{lost}). ✓ Therefore the voltmeter reading V increases. ✓ (3) [15]

QUESTION 6

<p>6.1.1 OPTION 1 $P = \frac{V^2}{R} \checkmark$ $4 = \frac{V^2}{R} = \frac{(12)^2}{R} \checkmark$ $R = 36 \Omega \checkmark$</p>	<p>OPTION 2 $P = VI$ $4 = I(12)$ $I = 0,33...A$ $V = IR \checkmark$ $12 = 0,33R \checkmark$ $R = 36,36 \Omega \checkmark$</p>	<p>OPTION 3 $P = VI$ $4 = I(12)$ $I = 0,33 \dots A$ $P = I^2 R \checkmark$ $4 = (0,33^2)R \checkmark$ $R = 36,73 \Omega \checkmark$</p>
--	--	--

6.1.2 Increase ✓ (1)

6.1.3 No change ✓ Same potential difference ✓ (and resistance) (2)

6.2.1

$V = IR \checkmark$ $5 = I(6) \checkmark$ $\therefore I = 0,83 \text{ A}$	OR	$\mathcal{E} = I(R + r)$ $6 = (0,83)(6 + r) \checkmark$ $r = 1,23 \Omega \checkmark$
$V^{\text{lost}} = Ir$ $1 = (0,83)r \checkmark$ $r = 1,20 \Omega \checkmark$		

(4)

6.2.2 Work done \checkmark in moving a unit charge \checkmark through a cell. (2)

6.2.3 **POSITIVE MARKING FROM QUESTION 6.2.1.**

<p>OPTION 1</p> $V^{\text{lost}} = Ir$ $1,5 \checkmark = I(1,2)$ $I = 1,25 \text{ A}$ $V_{ } = I_6 R_6$ $4,5 = I_6(6)$ $I_6 = 0,75 \text{ A}$ $V_x = IR_x \checkmark$ $4,5 = (1,25 - 0,75)R_x \checkmark$ $R_x = 9 \Omega \checkmark$	<p>OPTION 2</p> $V^{\text{lost}} = Ir$ $1,5 \checkmark = I(1,2)$ $I = 1,25 \text{ A}$ $V_{ } = I_p R_p$ $4,5 = (1,25)R_p \checkmark$ $R_p = 3,6 \Omega$ $\frac{1}{R_{ }} = \frac{1}{R_x} + \frac{1}{R_6} \checkmark$ $\frac{1}{R_{ }} = \frac{1}{R_x} + \frac{1}{6} \checkmark$ $\therefore R_{ } = \frac{6R_x}{R_x + 6} = 3,6 \quad \therefore R_x = 9 \Omega \checkmark$
---	---

(5)
[17]

QUESTION 7

7.1.1 (Maximum) energy provided (work done) by a battery per coulomb/unit charge passing through it. $\checkmark \checkmark$ (2)

7.1.2 12 V \checkmark (1)

7.1.3 0 V / Zero \checkmark (1)

7.1.4

<p>OPTION 1</p> $\mathcal{E} = I(R + r) \text{ OR } \mathcal{E} = V_{\text{ext}} + V_{\text{int}} \checkmark$ $12 = 11,7 + Ir$ $0,3 = I_{\text{tot}}(0,2) \checkmark \quad \therefore I_{\text{tot}} = 1,5 \text{ A} \checkmark$	<p>OPTION 2</p> $V = IR \checkmark$ $0,3 = I_{\text{tot}}(0,2) \checkmark$ $I_{\text{tot}} = 1,5 \text{ A} \checkmark$
---	---

(3)

7.1.5 $\frac{1}{R_p} = \frac{1}{R_1} + \frac{1}{R_2} = \frac{1}{10} + \frac{1}{15} \quad \therefore R = 6 \Omega \checkmark$ (2)

7.1.6 **POSITIVE MARKING FROM QUESTIONS 7.1.4 AND 7.1.5.**

<p>OPTION 1</p> $V = IR \checkmark$ $11,7 \checkmark = 1,5(6 + R) \checkmark$ $R = 1,8 \Omega \checkmark$	<p>OPTION 2</p> $V = IR \checkmark$ $11,7 = 1,5R \checkmark$ $R = 7,8 \Omega$ $R_R = 7,8 - 6 \checkmark \checkmark \quad (\text{for subtraction})$ $= 1,8 \Omega \checkmark$
--	---

(4)

7.2.1

<p>OPTION 1</p> $P_{\text{ave}} = FV_{\text{ave}} \checkmark = mg(v_{\text{ave}})$ $= (0,35)(9,8)(0,4) \checkmark$ $= 1,37 \text{ W} \checkmark$	<p>OPTION 2</p> $P = \frac{W_{\text{nc}}}{\Delta t} \checkmark = \frac{\Delta E_k + \Delta E_p}{\Delta t}$ $= \frac{0 + (0,35)(9,8)(0,4 - 0)}{1} \checkmark$ $= 1,37 \text{ W} \checkmark$	<p>OPTION 3</p> $P = \frac{W}{\Delta t} \checkmark = \frac{\Delta E_p}{\Delta t}$ $= \frac{(0,35)(9,8)(0,4)}{1} \checkmark$ $= 1,37 \text{ W} \checkmark$
---	---	--

(3)

7.2.2 **POSITIVE MARKING FROM QUESTION 7.2.1.**

<p>OPTION 1</p> <p>$P = VI$ $1,37 = (3)I$ ✓ $I = 0,46 \text{ A}$</p> <p>$\epsilon = V_{\text{ext}} + V_{\text{int}}$ $= V_T + V_X + V_{\text{int}}$ $12 = V_T + 3 + (0,2)(0,46)$ ✓ $V_T = 8,91 \text{ V}$</p> <p>$V_T = IR_T$ $8,91 = (0,46)R_T$ ✓ $R_T = 19,37 \Omega$ ✓</p>	<p>OPTION 2</p> <p>$P = \frac{V^2}{R}$ $1,37 = \frac{3^2}{R}$ ✓ $R = 6,57 \Omega$</p> <p>$P = VI$ $1,37 = (3)I$ ✓ $I = 0,46 \text{ A}$</p> <p>$\epsilon = I(R + r)$ $12 = 0,46(6,57 + R_T + 0,2)$ ✓ $\therefore R_T = 19,38 \Omega$ ✓</p>
---	---

✓ Any one

(5)
[21]

QUESTION 8

8.1.1 The potential difference across a conductor is directly proportional to the current in the conductor ✓ at constant temperature ✓

(2)

8.1.2

Graph of potential difference versus current

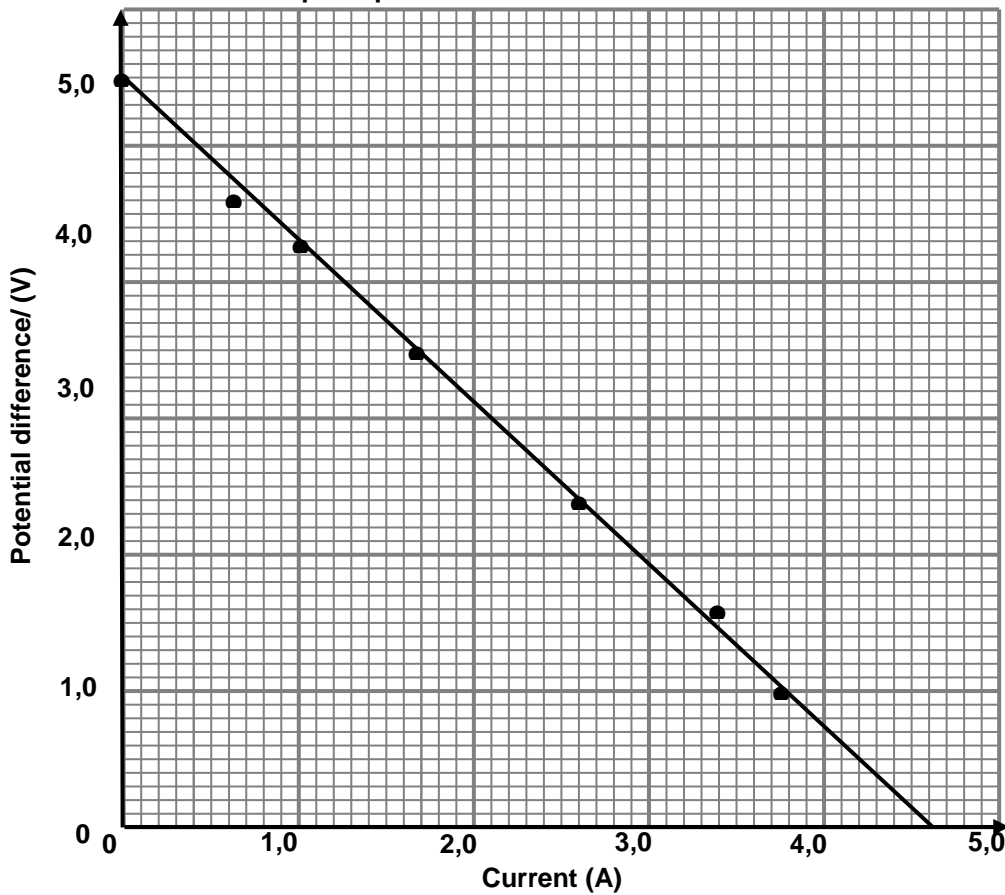

Straight line passing through 4 or five points. ✓
 Straight line with intercepts on both axes. ✓

(2)

8.1.3 5,5 V (Accept any value from 5,4 V to 5,6 V.)

NOTE: The value must be the y-intercept.

(1)

8.1.4 Slope = $\frac{\Delta V}{\Delta I}$ ✓ or $\frac{y_2 - y_1}{x_2 - x_1} = \frac{5,5 - 0}{0 - 4,6}$ ✓ = - 1,2 ∴ Internal resistance(r) = 1,2 Ω ✓

NOTE: Any correct pair of coordinates chosen from the line drawn

(3)

8.2.1 $V = IR \therefore 21,84 = I_{\text{tot}}(8)$ ✓ ∴ $I_{\text{tot}} = 2,73 \text{ A}$ ✓

(3)

8.2.2 **POSITIVE MARKING FROM QUESTION 8.2.1.**

$$\frac{1}{R_{//}} = \frac{1}{R_{30}} + \frac{1}{R_{20}} \therefore \frac{1}{R_{//}} = \frac{1}{30} + \frac{1}{20} \checkmark \therefore R_{//} = 12 \Omega \checkmark$$

(2)

8.2.3 **POSITIVE MARKING FROM QUESTION 8.2.1 AND 8.2.2.**

OPTION 1

$$R_{\text{tot}} = (8 + 12 + r) \checkmark = (20 + r)$$

$$\mathcal{E} = I(R + r) \checkmark \therefore 60 = 2,73(20 + r) \checkmark \therefore r = 1,98 \Omega \checkmark$$

POSITIVE MARKING FROM QUESTION 8.2.1.

OPTION 2

$$V_{//} = I_{\text{tot}} \times R_{//} = 2,73(12) \checkmark = 32,76 \text{ V}$$

$$V_{\text{terminal}} = (32,76 + 21,84) \checkmark = 54,6 \text{ V}$$

$$V_{\text{lost}} = 60 - 54,6 = 5,4 \text{ V}$$

$$V = IR \therefore 5,4 = 2,73 r \therefore r = 1,98 \Omega \checkmark$$

OR

$$\mathcal{E} = V_{\text{lost}} + V_{//} + V_8$$

$$60 = (V_{\text{lost}} + 32,76 + 21,84) \checkmark$$

$$V_{\text{lost}} = 5,4 \text{ V}$$

(4)

8.2.4 **POSITIVE MARKING FROM QUESTION 8.2.1 AND 8.2.2.**

OPTION 1

$$W = \frac{V^2}{R} \Delta t \checkmark$$

$$W = \frac{(54,6)^2}{20} (0,2) \checkmark = 29,81 \text{ J} \checkmark$$

OPTION 2

$$W = I^2 R \Delta t \checkmark$$

$$= (2,73)^2 (20)(0,2) \checkmark$$

$$= 29,81 \text{ J} \checkmark$$

OPTION 3

$$W = VI \Delta t \checkmark$$

$$= (54,6)(2,73)(0,2) \checkmark$$

$$= 29,81 \text{ J} \checkmark$$

(3)
[20]

QUESTION 9

9.1.1 **P and Q burn with the same brightness** \checkmark same potential difference/same current \checkmark

(2)

9.1.2 **P is dimmer (less bright) than R./R is brighter than P.** \checkmark

R is connected across the battery alone therefore the voltage (terminal pd) is the same as the emf source (energy delivered by the source). \checkmark

OR: The potential difference across R is twice (larger/greater than) that of P./The current through R is twice (larger/greater than) that of P.

(2)

9.1.3 **T does not light up at all.** \checkmark R is brighter than T. \checkmark **Reason:** The wire acts as a short circuit. \checkmark

OR: The potential difference across T / current in T is zero. \checkmark

(2)

9.2.1

$\frac{1}{R_{//}} = \frac{1}{R_5} + \frac{1}{R_{10}} \checkmark = \frac{1}{5} + \frac{1}{10} \therefore R_{//} = 3,33 \Omega \quad (3,333 \Omega)$ <p>OR</p> $R_{//} = \frac{R_5 R_{10}}{R_5 + R_{10}} \checkmark = \frac{(5)(10)}{(5+10)} \checkmark = 3,33 \Omega \quad (3,333 \Omega)$	
$R_{\text{tot}} = R_8 + R_{//} + r = (8 + 3,33 + 1) \checkmark = 12,33 \Omega$ $I_{\text{tot}} = \frac{V}{R} \checkmark = \frac{20}{12,33} \checkmark = 1,62 \text{ A}$ $\therefore I_8 = 1,62 \text{ A} \checkmark$	$R = R_8 + R_{//} = 8 + 3,33 = 11,33 \Omega$ $\mathcal{E} = I(R + r) \checkmark$ $20 = I[(11,33 + 1) \checkmark] \checkmark$ $I = 1,62 \text{ A} \checkmark$

(6)

9.2.2

<p>OPTION 1</p> $V = IR$ $V_5 = \mathcal{E} - (V_8 + V_1) \checkmark \text{ Any one}$ $= 20 \checkmark - [1,62(8 + 1)] \checkmark = 5,42 \text{ V} \checkmark$			
<p>OPTION 2</p> <p>POSITIVE MARKING FROM QUESTION 9.2.1.</p> $R_{//} = \frac{(5)(10)}{(5+10)} = 3,33 \Omega$ $V_{R//} = \frac{R_{//}}{R_{\text{tot}}} \times V_{\text{tot}} \checkmark \therefore V_{R//} = \frac{(3,33)}{(12,33)} (20) \checkmark \checkmark = 5,41 \text{ V} \checkmark$			
<table style="width: 100%; border: none;"> <tr> <td style="border: none; padding-right: 10px;"> $V_{//} = IR_{//} \checkmark$ $= (1,62)(3,33) \checkmark \checkmark$ $= 5,39 \text{ V} \checkmark$ </td> <td style="border: none; text-align: center;"> \rightarrow </td> </tr> </table>		$V_{//} = IR_{//} \checkmark$ $= (1,62)(3,33) \checkmark \checkmark$ $= 5,39 \text{ V} \checkmark$	\rightarrow
$V_{//} = IR_{//} \checkmark$ $= (1,62)(3,33) \checkmark \checkmark$ $= 5,39 \text{ V} \checkmark$	\rightarrow		

(4)

9.2.3 **POSITIVE MARKING FROM QUESTION 9.2.1.**

<p>OPTION 1 $P = IV \checkmark$ $= (1,62)(20) \checkmark$ $= 32,4 \text{ W} \checkmark$</p>	<p>OPTION 2 $P = I^2R \checkmark$ $P_{\text{tot}} = P_{8\Omega} + P_{\parallel} + P_{1\Omega}$ $= I^2(R_8 + R_{\parallel} + R_1)$ $= (1,62)^2[8 + 3,33 + 1] \checkmark = 32,36 \text{ W} \checkmark$</p>
--	---

(3)
[19]

QUESTION 10

10.1.1 The potential difference (voltage) across a conductor is directly proportional to the current in the conductor at constant temperature. $\checkmark\checkmark$ (2)

10.1.2 Equivalent resistance \checkmark (1)

10.1.3 Gradient = $\frac{\Delta V}{\Delta I} = \frac{2-0}{0,5-0} \checkmark = 4 \text{ } (\Omega) \checkmark$

NOTE: Any correctly chosen pair of coordinates / Enige korrekte paar koördinate. (2)

10.1.4 **POSITIVE MARKING FROM QUESTION 10.1.3.**

<p>OPTION 1 In series $R_1 + R_2 = 4 \text{ } \Omega \checkmark \dots\dots\dots(1)$ In parallel $\frac{R_1 R_2}{R_1 + R_2} = 1 \text{ } \Omega \checkmark\checkmark \dots\dots\dots(2)$ $R_1 R_2 = 4 \text{ } \Omega$ $\therefore R_1 = R_2 = 2 \text{ } \Omega \checkmark$</p>	<p>OPTION 2 For graph X: $R_1 + R_2 = 4 \text{ } \Omega \checkmark \dots\dots\dots(1)$ For graph Y: $\frac{1}{R_{\parallel}} = \frac{1}{R_1} + \frac{1}{R_2}$ $\left\{ \left(\frac{1}{R_1} + \frac{1}{R_2} \right) = \left(\frac{1}{1} \right) \right\} \checkmark\checkmark \dots\dots\dots(2)$ $R_1^2 - 4R_1 + 4 = 0 \therefore R_1 = 2 \text{ } \Omega \checkmark$</p>
--	--

(4)

10.2.1 $I = \frac{V}{R} \checkmark = \frac{5}{(R_M + R_N)} = \frac{5}{6} \checkmark = 0,83 \text{ A} \checkmark$ (3)

10.2.2 **POSITIVE MARKING FROM QUESTION 10.2.1.**

<p>OPTION 1 $\mathcal{E} = I(R + r) \checkmark = 0,83[(6 + 1,5) \checkmark + 0,9 \checkmark]$ $= 6,997 \text{ V} = 7(,00) \text{ V} \checkmark (6,972 - 7,00 \text{ V})$</p>	<p>OPTION 2 $\mathcal{E} = (V_s + V_{\parallel} + V_r) \checkmark / V_{\text{ext}} + V_{\text{int}}$ $= [5 + (0,833 \times 1,5) \checkmark + (0,9 \times 0,833)] \checkmark\checkmark$ $= 6,999 \text{ V} = 7(,00) \text{ V} \checkmark (6,972 - 7,00 \text{ V})$</p>
---	--

(4)

10.2.3 The resistance R_N will be $3 \text{ } \Omega \checkmark$
 - The voltage divides (proportionately) in a series circuit. Since the voltage across M is half the total voltage, it means the resistances of M and N are equal. \checkmark (2)
[18]

QUESTION 11

11.1.1 The potential difference across a conductor is directly proportional to the current in the conductor at constant temperature.
OR The ratio of potential difference across a conductor to the current in the conductor is constant, provided the temperature remains constant. (2)

11.1.2 Graph X. \checkmark Graph X is a straight line (passing through the origin) therefore potential difference is directly proportional to current. \checkmark (2)

11.2.1 $\frac{1}{R_{\parallel}} = \frac{1}{R_{10}} + \frac{1}{R_{15}} \quad R = 10 + 6 + 2 \checkmark \quad R = \frac{V}{I} \checkmark$
 $\quad \quad \quad = 18 \text{ } \Omega$
 $\frac{1}{R_{\parallel}} = \frac{1}{10} + \frac{1}{15} \checkmark \quad I = \frac{6}{18} \checkmark$
 $R_{\parallel} = 6 \text{ } \Omega \quad = 0,33 \text{ A} \checkmark$ (5)

11.2.2 Decrease \checkmark The total resistance of the circuit increases. \checkmark (2)

11.2.3 Increase \checkmark (1)

11.2.4 The total resistance in the external circuit increases. \checkmark
Current decreases \checkmark
"Lost" volts decreases \checkmark (3)
[15]

QUESTION 12

12.1.1 The potential difference across a conductor is directly proportional to the current in the conductor at constant temperature.

OR The ratio of potential difference across a conductor to the current in the conductor is constant, provided the temperature remains constant.

(2)

12.1.2 $V_1 = IR \checkmark = (0,6)(4) \checkmark = 2,4 \text{ V} \checkmark$

(3)

12.1.3 **POSITIVE MARKING FROM QUESTION 12.1.2.**

<u>OPTION 1</u>	<u>OPTION 2</u>	<u>OPTION 2</u>
$I_{6\Omega} = \frac{V}{R} = \frac{2,4}{6} \checkmark = 0,4 \text{ A} \checkmark$	$\frac{6}{10}(I) = 0,6 \checkmark$ $\therefore I = 1 \text{ A} \therefore I_{6\Omega} = 0,4 \text{ A} \checkmark$	$V_{4\Omega} = V_{6\Omega} \therefore I_{4\Omega}R_1 = I_{6\Omega}R_2$ $(0,6)(4) = I_{6\Omega}(6) \checkmark$ $I_{6\Omega} = 0,4 \text{ A} \checkmark$

(2)

12.1.4 **POSITIVE MARKING FROM QUESTION 12.1.3.**

$V_2 = IR = (0,4 + 0,6)(5,8) \checkmark = 5,8 \text{ V} \checkmark$

(2)

12.1.5 **POSITIVE MARKING FROM QUESTIONS 12.1.4 AND 12.1.2.**

<u>OPTION 1</u>	<u>OPTION 2</u>
$V_{\text{ext}} = (5,8 + 2,4) \checkmark = 8,2 \text{ V}$ $V_{\text{int}} = Ir$ $= (1)(0,8) \checkmark = 0,8 \text{ V}$ $\text{Emf} = 0,8 + 8,2 = 9 \text{ V} \checkmark$	$\frac{1}{R_p} = \frac{1}{R_1} + \frac{1}{R_2} = \frac{1}{6} + \frac{1}{4} = \frac{5}{12} \therefore R_p = 2,4 \Omega$ $R_{\text{ext}} = (2,4 + 5,8) \checkmark = 8,2 \Omega$ $\text{Emf} = I(R + r) = 1(8,2 + 0,8) \checkmark = 9 \text{ V} \checkmark$

(3)

12.1.6 **POSITIVE MARKING FROM QUESTIONS 12.1.5 AND Q12.1.3.**

<u>OPTION 1</u>	<u>OPTION 2</u>	<u>OPTION 3</u>
$W = VI \Delta t \checkmark$ $= (0,8)(1)(15) \checkmark$ $= 12 \text{ J} \checkmark$	$W = I^2R \Delta t \checkmark$ $= (1)^2(0,8)(15) \checkmark$ $= 12 \text{ J} \checkmark$	$W = \frac{V^2 \Delta t}{R} \checkmark = \frac{0,8^2(15)}{0,8} \checkmark = 12 \text{ J} \checkmark$

(3)

12.2.1 $R = \frac{V}{I} = \frac{2,8}{0,7} \checkmark = 4 \Omega \checkmark$

(2)

12.2.2 Increases \checkmark

(3)

Total resistance decreases, \checkmark current/power increases, \checkmark motor turns faster.

[20]**QUESTION 13**

13.1 The battery supplies 12 J per coulomb/per unit charge. $\checkmark \checkmark$

OR The potential difference of the battery in an open circuit is 12 V.

(2)

<u>OPTION 1</u>	<u>OPTION 2</u>	<u>OPTION 3</u>
$V_{\text{lost}} = Ir \checkmark = (2)(0,5) = 1 \text{ V}$ $V_{\text{ext}} = \text{Emf} - V_{\text{lost}} = (12 - 1) \checkmark = 11 \text{ V} \checkmark$	$\epsilon = I(R + r) \checkmark$ $12 = V_{\text{ext/eks}} + (2)(0,5) \checkmark$ $V_{\text{ext/eks}} = 11 \text{ V} \checkmark$	$\epsilon = I(R + r) \checkmark \checkmark$ $12 = 2(R + 0,5)$ $R = 5,5 \Omega$ $V = IR = 2(5,5) \checkmark$ $= 11 \text{ V} \checkmark$

(3)

13.3 **POSITIVE MARKING FROM Q13.2.**

<u>OPTION 1</u>	<u>OPTION 2</u>	<u>OPTION 3/OPSIE 3</u>
$R = \frac{V}{I} \checkmark = \frac{11}{2} = 5,5 \Omega \checkmark$	$0,5 : R = 1:11 \checkmark$ $R = 5,5 \Omega \checkmark$	$\frac{1}{0,5} = \frac{11}{R} \checkmark$ $R = 5,5 \Omega \checkmark$
<u>OPTION 4</u> $V_{\text{total}} = IR_{\text{total}}$ $12 = (2)R_{\text{total}}$ $R_{\text{total}} = 6 \Omega$ $R = 6 - 0,5 \checkmark$ $= 5,5 \Omega \checkmark$	<u>OPTION 5</u> $\epsilon = I(R + r)$ $12 = 2(R + 0,5) \checkmark$ $R = 5,5 \Omega \checkmark$	

(2)

13.4  Decreases \checkmark
Total resistance decreases. \checkmark
Current increases. \checkmark

"Lost volts" increases, \checkmark emf the same **OR** in $\epsilon = V_{\text{ext}} + Ir$, I increases \checkmark , ϵ is constant
External potential difference decreases

$\therefore V_{\text{ext/eks}}$ decreases

(4)

[11]

QUESTION 14

- 14.1 Temperature ✓ (1)
 14.2 $r = 3 \Omega$ or $1,5 \Omega$ ✓✓ (2)

14.3	Any correct values from the graph	POSITIVE MARKING FROM Q14.2.1.	
	OPTION 1 $\epsilon = \text{slope (gradient) of the graph} \checkmark$ $\epsilon = \frac{7,5 - (-3)}{1,5 - 0} \checkmark$ $= 7 \text{ V} \checkmark$	OPTION 2 $R = \frac{\epsilon}{I} - r \checkmark$ $7,5 = 1,5\epsilon - 3 \checkmark$ $\epsilon = 7 \text{ V} \checkmark$	OPTION 3 $\epsilon = I(R + r) \checkmark$ $= 0,5(11 + 3) \checkmark$ $\epsilon = 7 \text{ V} \checkmark$

(3)
[6]

ELECTRICAL MACHINES

QUESTION 1

- 1.1 Electromagnetic induction ✓ (1)
 1.2 Rotate coil faster./Increase number of coils./Increase the strength of the magnetic field. ✓ (1)
 1.3 Slip rings ✓ (1)
 1.4.1 It is the value of the voltage in a DC circuit ✓ that will have the same heating effect as an AC circuit. ✓ (2)
 1.4.2 $V_{\text{rms}} = \frac{V_{\text{max}}}{\sqrt{2}} \checkmark = \frac{339,45}{\sqrt{2}} \checkmark \therefore V_{\text{rms}} = 240,03 \text{ V} \checkmark$ (3)
[8]

QUESTION 2

2.1.1	OPTION 1 $P_{\text{ave}} = \frac{V_{\text{rms}}^2}{R} \checkmark$ $100 \checkmark = \frac{(\frac{340}{\sqrt{2}})^2}{R} \checkmark$ $R = 578 \Omega \checkmark$	OPTION 2 $V_{\text{rms}} = \frac{V_{\text{max}}}{\sqrt{2}} = \frac{340}{\sqrt{2}} = 240,04$ $P_{\text{ave}} = \frac{V_{\text{rms}}^2}{R} \checkmark$ $100 \checkmark = \frac{(240,04)^2}{R} \checkmark \therefore R = 578 \Omega \checkmark$
-------	--	--

(5)

2.1.2	OPTION 1 $P_{\text{ave}} = I_{\text{rms}} V_{\text{rms}} \checkmark$ $100 = I_{\text{rms}} \frac{340}{\sqrt{2}} \checkmark$ $I_{\text{rms}} = 0,417 \text{ A} \checkmark$	OPTION 2 $V_{\text{rms}} = I_{\text{rms}} R \checkmark$ $\frac{340}{\sqrt{2}} = I_{\text{rms}}(578) \checkmark$ $I_{\text{rms}} = 0,417 \text{ A} \checkmark$
-------	---	---

(3)

- 2.2 Can be stepped up or down. / Can be transmitted with less power loss. ✓ (1)
[9]

QUESTION 3

- 3.1.1 Anticlockwise ✓ (1)
 3.1.2

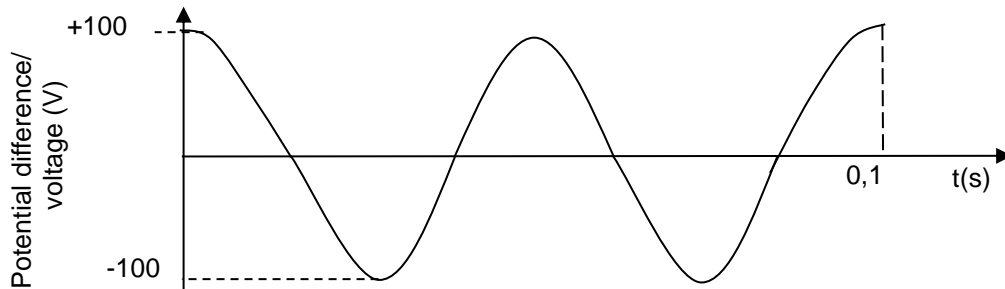

Criteria for graph:	
Two full cycles with correct shape.	✓
Showing the maximum voltage.	✓
Showing the time 0,1s for two cycles.	✓

(3)

- 3.1.3 Decrease the frequency/ speed of rotation ✓ (1)
- 3.2 $P_{ave} = V_{rms}I_{rms}$ ✓ ∴ $1\,500 = (220)(I_{rms})$ ✓ ∴ $I_{rms} = 6,82\text{ A}$
- $I_{rms} = \frac{I_{max}}{\sqrt{2}}$ ✓ ∴ $I_{max} = \sqrt{2}(6,82)$ ✓ = $9,65\text{ A}$ ✓ (5)
- [10]

QUESTION 4

- 4.1.1 Move the bar magnet very quickly ✓✓ **OR** up and down inside the coil. (2)
- 4.1.2 Electromagnetic induction ✓ (1)
- 4.1.3 Commutator ✓ (1)

4.2.1

<p>OPTION 1</p> $P_{ave} = \frac{V_{rms}^2}{R} \checkmark = \frac{(220)^2 \checkmark}{40,33 \checkmark}$ $= 1\,200,10\text{ W (J}\cdot\text{s}^{-1}) \checkmark$	$W = \frac{V_{rms}^2}{R} \Delta t \checkmark = \frac{(220)^2 \checkmark}{40,33 \checkmark} (1)$ $= 1\,200,10\text{ J} \checkmark$
<p>OPTION 2</p> $I_{rms} = \frac{V_{rms}}{R} \checkmark = \frac{220}{40,33} \checkmark = 5,45\text{ A}$ $P_{ave} = I_{rms}^2 R = (5,45)^2 (40,33) \checkmark$ $= 1\,197,9\text{ W / } 1\,200,10\text{ W} \checkmark$	$I_{rms} = \frac{V_{rms}}{R} \checkmark = \frac{220}{40,33} \checkmark = 5,45\text{ A}$ $W = I_{rms}^2 R \Delta t = (5,45)^2 (40,33) (1) \checkmark$ $= 1\,197,9\text{ J / } 1\,200,10\text{ J} \checkmark$
<p>OPTION 3</p> $I_{rms} = \frac{V_{rms}}{R} \checkmark = \frac{220}{40,33} \checkmark = 5,45\text{ A}$ $P_{ave} = V_{rms}I_{rms}$ $= (220)(5,45) \checkmark = 1\,199\text{ W / } 1\,200,10\text{ W} \checkmark$	$I_{rms} = \frac{V_{rms}}{R} \checkmark = \frac{220}{40,33} \checkmark = 5,45\text{ A}$ $W = V_{rms}I_{rms}\Delta t$ $= (220)(5,45)(1) = 1\,199\text{ J / } 1\,200,10\text{ J} \checkmark$

(4)

4.2.2 **POSITIVE MARKING FROM QUESTION 4.2.1.**

<p>OPTION 1</p> $V_{rms} = \frac{V_{max}}{\sqrt{2}}$ $220 = \frac{V_{max}}{\sqrt{2}}$ $V_{max} = 311,13\text{ V}$ $I_{max} = \frac{V_{max}}{R} = \frac{311,13}{40,33} \checkmark = 7,71\text{ A} \checkmark$ <p>OR</p> $P_{ave} = \frac{V_{max}I_{max}}{2}$ $1\,200,1 = \frac{311,13I_{max}}{2} \therefore I_{max} = 7,71\text{ A}$	<p>OPTION 2</p> $P_{ave} = V_{rms}I_{rms} \checkmark$ $1\,200,1 = (220)I_{rms} \checkmark$ $I_{rms} = 5,455\text{ A}$ $I_{max} = \sqrt{2}(5,455)$ $= 7,71\text{ A} \checkmark (7,715\text{ A})$
<p>OPTION 3</p> $P_{ave} = I_{rms}^2 R \checkmark$ $1\,200,1 = I_{rms}^2 (40,33) \checkmark$ $I_{rms} = 5,455\text{ A}$ $I_{max} = \sqrt{2} I_{rms} = \sqrt{2} (5,455) = 7,71\text{ A} \checkmark$	<p>OPTION 4</p> $V_{rms} = I_{rms}R \checkmark$ $220 = I_{rms}(40,33) \checkmark$ $I_{rms} = 5,455\text{ A}$ $I_{max} = \sqrt{2} I_{rms} = \sqrt{2} (5,455) = 7,71\text{ A} \checkmark$

(3)

[11]

QUESTION 5

- 5.1.1 North pole ✓ (1)
- 5.1.2 Q to P ✓ (1)

5.2.1

<p>OPTION 1</p> $I_{rms} = \frac{I_{max}}{\sqrt{2}} \checkmark = \frac{8}{\sqrt{2}} \checkmark = 5,66 \text{ A}$ $V_{rms} = I_{rms}R \checkmark$ $220 = 5,66R \checkmark$ $\therefore R = 38,87 \Omega \checkmark$	<p>OPTION 2</p> $V_{rms} = \frac{V_{max}}{\sqrt{2}} \checkmark \therefore 220 = \frac{V_{max}}{\sqrt{2}} \checkmark$ $\therefore V_{max} = 311,12 \text{ V}$ $V_{max} = I_{max}R \checkmark$ $311,12 = 8R \checkmark$ $\therefore R = 38,89 \Omega \checkmark$
---	---

(5)

5.2.2

<p>OPTION 1</p> $P_{ave} = V_{rms}I_{rms} \checkmark$ $= (220)(5,66) \checkmark$ $= 1\,245,2 \text{ W}$ $P = \frac{W}{\Delta t} \checkmark$ $1\,245,22 = \frac{W}{7200} \checkmark$ $W = 8\,965\,584 \text{ J} \checkmark$	<p>OPTION 2</p> $P_{ave} = I_{rms}^2 R \checkmark$ $= (5,66)^2(38,87) \checkmark$ $= 1\,245,22 \text{ W}$ $P = \frac{W}{\Delta t} \checkmark$ $1\,245,22 = \frac{W}{7200} \checkmark$ $W = 8\,965\,584 \text{ J} \checkmark$	<p>OPTION 3</p> $P_{ave} = \frac{V_{rms}^2}{R} \checkmark = \frac{(220)^2}{38,87} \checkmark$ $= 1\,245,18 \text{ W}$ $P = \frac{W}{\Delta t} \checkmark$ $1\,245,22 = \frac{W}{7200} \checkmark$ $W = 8\,965\,584 \text{ J} \checkmark$
---	---	---

(5)
[12]

QUESTION 6

6.1.1

a to b ✓

(1)

6.1.2

Fleming's left hand rule /Left hand motor rule ✓

(1)

6.1.3

Split rings /commutator ✓

(1)

6.2.1

Mechanical/Kinetic energy to electrical energy ✓✓

(2)

6.2.2

<p>OPTION 1</p> $V_{rms} = \frac{V_{max}}{\sqrt{2}} \checkmark = \frac{430}{\sqrt{2}} \checkmark = 304,06 \text{ V}$ $I = \frac{V}{R} \checkmark = \frac{304,06}{400} \checkmark = 0,76 \text{ A} \checkmark$	<p>OPTION 2</p> $V_{max} = I_{max}R \checkmark$ $430 = I_{max}(400) \checkmark$ $I_{max} = 1,075$ $I_{rms} = \frac{I_{rms}}{\sqrt{2}} \checkmark = \frac{1,075}{\sqrt{2}} \checkmark = 0,76 \text{ A} \checkmark$
<p>OPTION 3</p> $V_{rms} = \frac{V_{max}}{\sqrt{2}} \checkmark = \frac{430}{\sqrt{2}} \checkmark = 304,06 \text{ V}$ $P_{ave} = \frac{V_{rms}^2}{R} = \frac{(304,06)^2}{400} = 231,13 \text{ W}$ $P_{ave} = I_{rms}V_{rms} \checkmark$ $231,13 = I_{rms}(304,06) \checkmark \therefore I_{rms} = 0,76 \text{ A} \checkmark$	<p>OPTION 4</p> $V_{rms} = \frac{V_{max}}{\sqrt{2}} \checkmark = \frac{430}{\sqrt{2}} \checkmark = 304,06 \text{ V}$ $P_{ave} = \frac{V_{rms}^2}{R} = \frac{(304,06)^2}{400} = 231,13 \text{ W}$ $P_{ave} = I_{rms}^2 R \checkmark$ $231,13 = I_{rms}^2 (400) \checkmark \therefore I_{rms} = 0,76 \text{ A} \checkmark$

(5)
[10]

QUESTION 7

7.1.1

DC-generator ✓
Uses split ring/commutator ✓

(2)

7.1.2

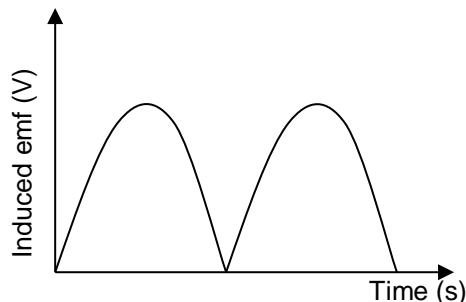

OR

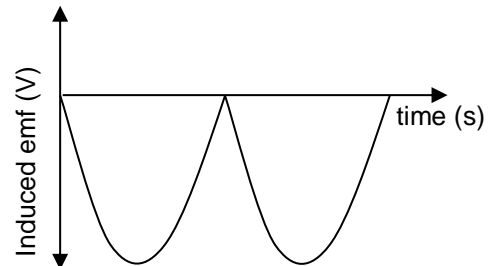

Curve starts at zero to first peak. ✓
Shape and one complete DC cycle. ✓

(2)

7.2.1

<p>OPTION 1</p> $V_{rms} = \frac{V_{max}}{\sqrt{2}} = \frac{340}{\sqrt{2}} = 240,416 \text{ V}$ $P_{ave} = V_{rms} I_{rms} \checkmark$ $800 = I_{rms} (240,416) \checkmark$ $I_{rms} = 3,33 \text{ A} \checkmark$	<p>OPTION 2</p> $V_{rms} = \frac{V_{max}}{\sqrt{2}} = \frac{340}{\sqrt{2}}$ $P_{ave} = V_{rms} I_{rms} \checkmark$ $800 = \frac{340}{\sqrt{2}} I_{rms} \checkmark \quad \therefore I_{rms} = 3,33 \text{ A} \checkmark$
<p>OPTION 3</p> $P_{ave} = \frac{V_{rms}^2}{R} = \frac{V_{max}^2}{2R}$ $800 = \frac{(340)^2}{(\sqrt{2})^2 R} \quad \therefore R = 72,25 \Omega$ $V_{rms} = I_{rms} R \checkmark$ $I_{rms} = \frac{240,416}{72,25} \checkmark = 3,33 \text{ A} \checkmark$	<p>OPTION 4</p> $P_{ave} = I_{rms}^2 R \checkmark$ $800 = I_{rms}^2 (72,25) \checkmark$ $I_{rms} = 3,33 \text{ A} \checkmark$

(3)

7.2.2

POSITIVE MARKING FROM QUESTION 7.2.1.

<p>OPTION 1</p> <p>For the kettle:</p> $P_{ave} = V_{rms} I_{rms} \checkmark$ $2000 = \frac{340}{\sqrt{2}} I_{rms} \checkmark \quad \therefore I_{rms} = 8,32 \text{ A}$ $I_{tot} = (8,32 + 3,33) \checkmark$ $= 11,65 \text{ A} \checkmark$	<p>OPTION 2</p> $P_{ave} = V_{rms} I_{rms} \checkmark = \frac{V_{max} I_{max}}{2}$ $2\ 800 = \frac{340}{2} I_{max} \checkmark \quad \therefore I_{max} = 16,47 \text{ A}$ $I_{rms} = \frac{I_{max}}{\sqrt{2}} = \frac{16,47}{\sqrt{2}} \checkmark \quad \therefore I_{rms} = 11,65 \text{ A} \checkmark$
---	---

(4)

[11]

QUESTION 8

- 8.1.1 R: armature/coil(s) \checkmark
 T: Carbon brushes \checkmark
 X: Slip rings \checkmark

(3)

8.1.2 Faraday's Law \checkmark

(1)

8.2.1 15 V \checkmark

(1)

8.2.2

<p>OPTION 1</p> $V_{rms} = I_{rms} R$ $I_{rms} = \frac{15}{45} \checkmark$ $= 0,333 \text{ A}$ $I_{rms} = \frac{I_{max}}{\sqrt{2}}$ $I_{max} = (0,333) \sqrt{2} \checkmark = 0,47 \text{ A} \checkmark$	<p>OPTION 2</p> $V_{rms} = \frac{V_{max}}{\sqrt{2}}$ $V_{max} = (15) \sqrt{2} \checkmark$ $= 21,213 \text{ V}$ $V_{max} = I_{max} R$ $I_{max} = \frac{21,213}{45} \checkmark = 0,47 \text{ A} \checkmark$
<p>OPTION 3</p> $I_{max} = \sqrt{2} I_{rms} = \sqrt{2} \frac{V_{rms}}{R} = \sqrt{2} \frac{15}{45} \checkmark \checkmark = 0,47 \text{ A} \checkmark$	

(4)

[9]

QUESTION 9

9.1 Slip rings \checkmark

(1)

9.2

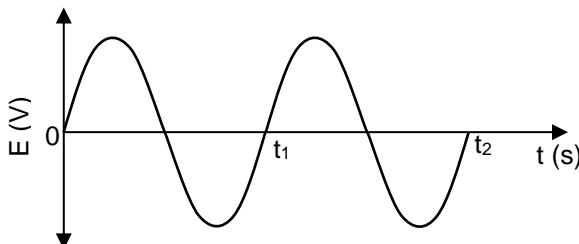

Marking criteria	
Sine graph starts from 0.	\checkmark
Two complete waves (between t_0 and t_2)	\checkmark

(2)

9.3 **Any TWO:**
 Increase the speed of rotation. ✓
 Increase the number of coils (turns). ✓
 Use stronger magnets. (2)

9.4 The rms value of an AC voltage is that value of the AC voltage which will dissipate the same amount of energy as DC. ✓✓
OR: The rms value of an AC voltage is that value of the AC voltage which will produce the same joule heating effect as DC. (2)

9.5

<p>OPTION 1 $P_{ave} = I_{rms} V_{rms}$ ✓ $1500 = I_{rms}/\omega k(240)$ ✓ $I_{rms} = \frac{1500}{240} = 6,25 \text{ A}$ ✓</p>	<p>OPTION 2 $P_{ave} = \frac{V^2}{R}$ ✓ $\therefore 1500 = \frac{240^2}{R}$ $\therefore R = 38,4 \Omega$ $I_{rms} = \frac{V}{R} = \frac{240}{38,4}$ ✓ = 6,25 A ✓</p>
---	---

(3)
[10]

QUESTION 10

10.1.1 Mechanical to electrical ✓ (1)

10.1.2

Induced emf vs t (s)

OR

Induced emf vs t (s)

Criteria for graph	
Correct DC shape, starting from zero	✓
Positions ABCDA correctly indicated on the graph	✓

(2)

10.2.1 20,5 Ω ✓ (1)

10.2.2 **POSITIVE MARKING FROM QUESTION 10.2.1.**

<p>OPTION 1 $I_{rms} = \frac{V_{rms}}{R} = \frac{25}{20,5}$ ✓ = 1,22 (1,2195) A</p>		
<p>$P_{ave} = I_{rms}^2 R$ $= (1,22)^2 (0,5)$ $= 0,74 \text{ W}$ $P_{ave} = \frac{V_{rms}^2}{R}$ ✓ = $\frac{(25)^2}{20,5}$ $= 30,49 \text{ W}$ Actual energy delivered per second (power) = (30,49 – 0,74) $= 29,75 \text{ W}$ ✓</p>	<p>$P_{ave} = I_{rms}^2 R$ ✓ $= (1,22)^2 (20)$ ✓ $= 29,77 \text{ W}$ ✓ OR $V_{rms \text{ device}} = \frac{20}{20,5} \times 25$ ✓ $= 24,39 \text{ V}$ $P_{ave} = V_{rms} I_{rms}$ ✓ $= (24,39)(1,22)$ $= 29,76 \text{ W}$ ✓</p>	<p>$W = I_{rms}^2 R \Delta t$ $= (1,22)^2 (0,5)(1)$ $= 0,74 \text{ J}$ $P_{ave} = \frac{V_{rms}^2}{R}$ ✓ = $\frac{(25)^2}{20,5}$ ✓ $= 30,49 \text{ W}$ Actual energy delivered per second (power) $= (30,49 – 0,74) = 29,75 \text{ W}$ ✓</p>
<p>OPTION 2 $V_{rms \text{ device}} = \frac{20}{20,5} \times 25$ ✓ = 24,39 V $P_{ave} = \frac{V_{rms}^2}{R}$ ✓ = $\frac{(24,39)^2}{20}$ ✓ = 29,74 W ✓</p>		

(5)
[9]

QUESTION 11

11.1.1 **ANY THREE**
 Permanent magnets; coils (armature); commutator; brushes; power supply/battery (3)

11.2.1 The rms voltage of AC is the potential difference which dissipates the same amount of energy as the equivalent DC potential difference. ✓✓ (2)

11.2.2

OPTION 1	OPTION 2
$V_{rms} = I_{rms} R$ $I_{rms} = \frac{V_{rms}}{R}$ $I_{rms} = \frac{240}{11}$ $= 21,82 \text{ A}$ $I_{rms} = \frac{I_{max}}{\sqrt{2}}$ $I_{max} = (21,82)\sqrt{2}$ $I_{max} = 30,86 \text{ A}$	$V_{rms} = \frac{V_{max}}{\sqrt{2}}$ $V_{max} = (240)\sqrt{2}$ $= 339,41$ $V_{max} = I_{max} R$ $I_{max} = \frac{339,41}{11}$ $I_{max} = 30,86 \text{ A}$

(4)
[9]

QUESTION 12

12.1.1 Split ring/commutator ✓ (1)

12.1.2 Anticlockwise ✓✓ (1)

12.1.3 Electrical energy ✓ to mechanical (kinetic) energy ✓ (2)

12.2.1 DC generator: split ring/commutator and AC generator has slip rings ✓ (2)

OR AC generator: slip ring and DC generator has split rings ✓

12.2.2 $V_{rms} = \frac{V_{max}}{\sqrt{2}} \checkmark = \frac{320}{\sqrt{2}} \checkmark = 226,27 \text{ V} \checkmark$ (3)

12.2.3 $I_{max} = \frac{V_{max}}{R} = \frac{320}{35} \checkmark = 9,14 \text{ A} \quad \therefore I_{rms} = \frac{I_{max}}{\sqrt{2}} \checkmark = \frac{9,14}{\sqrt{2}} \checkmark = 6,46 \text{ A} \checkmark$ (4)

[13]

QUESTION 13

13.1.1 Y to na X ✓ (1)

13.1.2 Faraday's Law Electromagnetic Induction ✓ (1)

OR Electromagnetic induction/Faraday's Law ✓

13.1.3 Mechanical (kinetic) energy ✓ to electrical energy ✓ (2)

13.2.1 340 V ✓ (1)

13.2.2 $V_{rms/wgk} = \frac{V_{max/maks}}{\sqrt{2}} \checkmark = \frac{340}{\sqrt{2}} \checkmark \therefore V_{rms/wgk} = 240,42 \text{ V} \checkmark$ (3)

13.2.3 **POSITIVE MARKING FROM Q13.2.2.**

OPTION 1

$P_{ave/gemid} = \frac{V_{rms/wgk}^2}{R} \checkmark$
 $1\ 600 = \frac{(240,42)^2}{R} \checkmark \therefore R = 36,13 \ \Omega \checkmark$

OPTION 2

$P_{ave/gemid} = \frac{V_{rms/wgk}^2}{R} \checkmark = \frac{V_{max/maks}^2}{2R} = \frac{V_{max/maks}^2}{2R}$
 $\therefore 1\ 600 = \frac{(340)^2}{2R} \checkmark \therefore R = 36,13 \ \Omega \checkmark$

(3)
[11]

OPTICAL PHENOMENA AND PROPERTIES OF MATERIALS

QUESTION 1

1.1 The minimum frequency of light needed to emit electrons ✓ from the surface of a metal. ✓ (2)

1.2 $E = W_0 + E_{k(max)}$
 $E = W_0 + \frac{1}{2}mv_{max}^2$
 $h\frac{c}{\lambda} = hf_0 + \frac{1}{2}mv_{max}^2$ } ✓ Any one

$\frac{(6,63 \times 10^{-34})(3 \times 10^8)}{\lambda} \checkmark = (6,63 \times 10^{-34})(5,548 \times 10^{14}) \checkmark + \frac{1}{2}(9,11 \times 10^{-31})(5,33 \times 10^5)^2 \checkmark$
 $\lambda = 4 \times 10^{-7} \text{ m} \checkmark$

(5)
(1)

- 1.4 The wavelength/frequency/energy of the incident light/photon is constant. ✓
 Since the speed is higher, the kinetic energy is higher ✓ and the work function / W_0 / threshold frequency smaller. ✓ (3)
 [11]

QUESTION 2

- 2.1 The minimum energy needed to emit an electron ✓ from (the surface of) a metal. ✓ (2)

2.2
$$E = W_0 + \frac{1}{2}mv_{\max}^2$$

$$h\frac{c}{\lambda} = W_0 + \frac{1}{2}mv_{\max}^2$$

$$\frac{(6,63 \times 10^{-34})(3 \times 10^8)}{(\lambda)} = (3,36 \times 10^{-19}) + 2,32 \times 10^{-19}$$
 Any ONE OF/ENIGE EEN van ✓ (4)

2.3
$$E = W_0 + \frac{1}{2}mv_{\max}^2$$
 OR/OR ✓

$$h\frac{c}{\lambda} = W_0 + \frac{1}{2}mv_{\max}^2$$

$$\frac{(6,63 \times 10^{-34})(3 \times 10^8)}{(3,50 \times 10^{-7})} = (3,65 \times 10^{-19}) + E_k$$

$$E = 2,03 \times 10^{-19} \text{ J} \checkmark$$
 (4)

- 2.4.1 Increasing the intensity does not change the energy / frequency / wavelength of the incident photons. ✓ **OR:** The energy of a photon remains unchanged (for the same frequency). (1)

- 2.4.2 Increases ✓ (1)

- 2.4.3 More photons/packets of energy strike the surface of the metal per unit time. ✓ Hence more (photo) electrons ejected per unit time ✓ leading to increased current. (2)
 [14]

QUESTION 3

- 3.1.1 The particle nature of light. ✓ (1)

- 3.1.2 Shorter wavelength means higher photon energy. ✓
 Photon energy is inversely proportional to wavelength ✓ ($E = \frac{hc}{\lambda}$).
 For the same metal, kinetic energy is proportional to photon energy. (2)

3.2.1

OPTION 1	OPTION 2
$W_0 = h\frac{c}{\lambda} \checkmark = \frac{(6,63 \times 10^{-34})(3 \times 10^8)}{330 \times 10^{-9}} \checkmark$ $\therefore W_0 = 6,03 \times 10^{-19} \text{ J} \checkmark$	$c = f\lambda \quad \therefore 3 \times 10^8 = f_0(330 \times 10^{-9}) \checkmark$ $\therefore f_0 = 9,09 \times 10^{14} \text{ Hz}$ $W_0 = hf_0 \quad \checkmark \text{ for both equations}$ $= (6,63 \times 10^{-34})(9,09 \times 10^7) \checkmark$ $= 6,03 \times 10^{-19} \text{ J} \checkmark$

 (4)

- 3.2.2 **POSITIVE MARKING FROM QUESTION 3.2.1.**

OPTION 1 $E = W_0 + E_k$ $hf = hf_0 + E_k$ $hf = hf_0 + \frac{1}{2}mv^2$ $E = W_0 + \frac{1}{2}mv^2$ $(6,63 \times 10^{-34})(1,2 \times 10^{15}) \checkmark = (6,03 \times 10^{-19}) \checkmark + \frac{1}{2}(9,11 \times 10^{-31})v^2 \checkmark \quad \therefore v = 6,5 \times 10^5 \text{ m}\cdot\text{s}^{-1} \checkmark$	} ✓ Any one
OPTION 2 $E_k = E_{\text{light}} - W_0$ $= hf_{\text{light}} - hf_0$ $= (6,63 \times 10^{-34})(1,2 \times 10^{15}) \checkmark - 6,03 \times 10^{-19} \checkmark = 1,926 \times 10^{-19} \text{ J}$ $E_k = \frac{1}{2}mv^2 \quad \therefore 1,926 \times 10^{-19} = \frac{1}{2}(9,11 \times 10^{-31})v^2 \checkmark \quad \therefore v = 6,5 \times 10^5 \text{ m}\cdot\text{s}^{-1} \checkmark$	} ✓ Any one

 (5)
 [12]

QUESTION 4

- 4.1 It is the process whereby electrons are ejected from a metal surface when light of suitable frequency is incident on it. ✓✓
OR: It is the phenomenon that occurs when light of suitable frequency, incident on a metal surface, ejects electrons from the metal surface. ✓✓ (2)

4.2

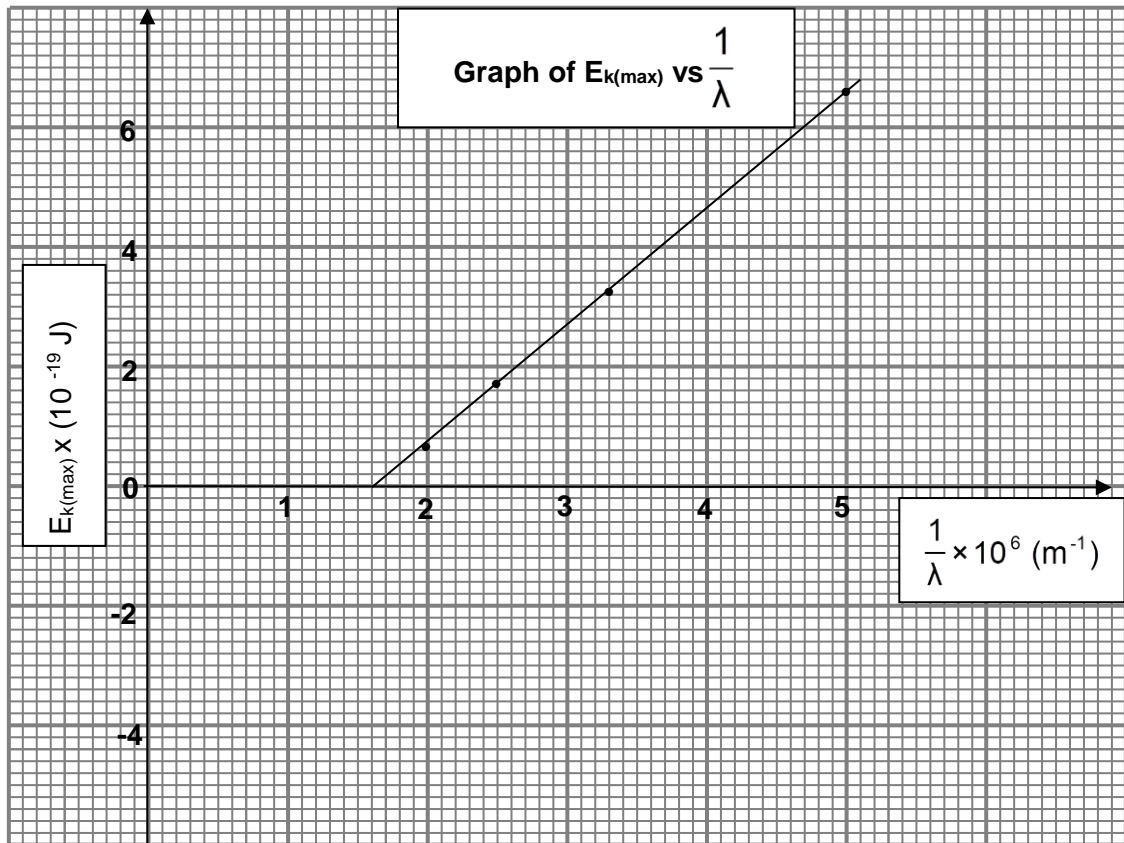

Criteria for drawing line of best fit:	
ALL points correctly plotted (at least 3 points)	✓✓
Correct line of best fit if all plotted points are used.	✓

(3)

4.3.1

POSITIVE MARKING FROM QUESTION 4.2.**OPTION 1**

$$\frac{1}{\lambda} = 1,6 \times 10^6 \text{ m}^{-1} \checkmark \quad (\text{Accept } 1,6 \times 10^6 \text{ m}^{-1} \text{ to } 1,7 \times 10^6 \text{ m}^{-1})$$

$$f_0 = c \frac{1}{\lambda} \checkmark = (3 \times 10^8)(1,6 \times 10^6) \checkmark = 4,8 \times 10^{14} \text{ Hz} \checkmark \quad (\text{Accept } 4,8 \times 10^{14} \text{ Hz to } 5,1 \times 10^{14} \text{ Hz})$$

OPTION 2By extrapolation: y-intercept = $-W_0$

$$W_0 = hf_0 \checkmark$$

$$3,2 \times 10^{-19} \checkmark = (6,63 \times 10^{-34})f_0 \checkmark$$

$$f_0 = 4,8 \times 10^{14} \text{ Hz} \checkmark \quad (\text{Accept } 4,8 \times 10^{14} \text{ Hz to } 4,83 \times 10^{14} \text{ Hz})$$

OPTION 3 (Points from the graph)

$$E = W_0 + E_{k(\max)}$$

$$\frac{hc}{\lambda} = hf_0 + E_{k(\max)} \checkmark$$

$$(6,63 \times 10^{-34})(3 \times 10^8)(1,6 \times 10^6) \checkmark = (6,63 \times 10^{-34})f_0 + 0 \checkmark \quad \therefore f_0 = 4,8 \times 10^{14} \text{ Hz} \checkmark$$

OR

$$6,63 \times 10^{-34}(3 \times 10^8)(5 \times 10^6) \checkmark = (6,63 \times 10^{-34})f_0 + 6,6 \times 10^{-19} \checkmark \quad \therefore f_0 = 4,92 \times 10^{14} \text{ Hz} \checkmark$$

OR

$$6,63 \times 10^{-34}(3 \times 10^8)(3,3 \times 10^6) \checkmark = (6,63 \times 10^{-34})f_0 + 3,3 \times 10^{-19} \checkmark \quad \therefore f_0 = 4,8 \times 10^{14} \text{ Hz} \checkmark$$

OR

$$6,63 \times 10^{-34}(3 \times 10^8)(2,5 \times 10^6) \checkmark = (6,63 \times 10^{-34})f_0 + 1,7 \times 10^{-19} \checkmark \quad \therefore f_0 = 4,94 \times 10^{14} \text{ Hz} \checkmark$$

OR

$$6,63 \times 10^{-34}(3 \times 10^8)(2,2 \times 10^6) \checkmark = (6,63 \times 10^{-34})f_0 + 0,7 \times 10^{-19} \checkmark \quad \therefore f_0 = 5,54 \times 10^{14} \text{ Hz} \checkmark$$

(4)

4.3.2 **POSITIVE MARKING FROM Q4.2.**

<p>OPTION 1</p> $hc = \text{gradient} \checkmark = \frac{\Delta y}{\Delta x} = \frac{6,6 \times 10^{-19}}{(5 - 1,6) \times 10^6} \checkmark$ $= 1,941 \times 10^{-25} \text{ (J}\cdot\text{m)}$ $h = \frac{\text{gradient}}{c} = \frac{1,941 \times 10^{-25}}{3 \times 10^8} \checkmark$ $= 6,47 \times 10^{-34} \text{ J}\cdot\text{s} \checkmark$	<p>OPTION 2</p> $W_0 = y \text{ intercept} \checkmark$ $= 3,2 \times 10^{-19} \text{ J} \checkmark$ <p>Accept: $3,2 \times 10^{-19} \text{ J}$ to $3,4 \times 10^{-19} \text{ J}$</p> $W_0 = hf_0$ $3,2 \times 10^{-19} \checkmark = h(4,8 \times 10^{14}) \checkmark$ $h = 6,66 \times 10^{-34} \text{ J}\cdot\text{s} \checkmark$ <p>Accept: $6,66 \times 10^{-34} \text{ J}\cdot\text{s}$ to $7,08 \times 10^{-34} \text{ J}\cdot\text{s}$</p>
<p>OPTION 3 (Points from the graph)</p> $\frac{hc}{\lambda} = W_0 + E_{k(\text{max})} = 3,2 \times 10^{-19} \checkmark + 6,6 \times 10^{-19} \checkmark$ $h = \frac{9,8 \times 10^{-19}}{(3 \times 10^8)(5 \times 10^6)} \checkmark = 6,53 \times 10^{-34} \text{ J}\cdot\text{s} \checkmark$ <p>OR</p> $\frac{hc}{\lambda} = W_0 + E_{k(\text{max})} = 3,2 \times 10^{-19} \checkmark + 3,3 \times 10^{-19} \checkmark$ $h = \frac{6,5 \times 10^{-19}}{(3 \times 10^8)(3,3 \times 10^6)} \checkmark = 6,57 \times 10^{-34} \text{ J}\cdot\text{s} \checkmark$ <p>OR</p> $\frac{hc}{\lambda} = W_0 + E_{k(\text{max})} = 3,2 \times 10^{-19} \checkmark + 1,7 \times 10^{-19} \checkmark$ $h = \frac{4,7 \times 10^{-19}}{(3 \times 10^8)(2,5 \times 10^6)} \checkmark = 6,27 \times 10^{-34} \text{ J}\cdot\text{s} \checkmark$	<p>OPTION 4</p> $W_0 = \frac{hc}{\lambda} \checkmark$ $3,2 \times 10^{-19} \checkmark = h(3 \times 10^8)(1,6 \times 10^6) \checkmark$ $h = 6,66 \times 10^{-34} \text{ J}\cdot\text{s} \checkmark$

(4)
[13]**QUESTION 5**

- 5.1 The minimum energy needed to emit an electron \checkmark from (the surface of) a metal. \checkmark (2)
- 5.2 Frequency/Intensity \checkmark (1)
- 5.3 The minimum frequency (of a photon/light) needed to emit electrons \checkmark from the surface of a certain metal. \checkmark (2)
- 5.4 $E = W_0 + E_k$ } \checkmark Any one/Enige een
 $hf = hf_0 + E_k$ }
 $(6,63 \times 10^{-34})(6,50 \times 10^{14}) \checkmark = (6,63 \times 10^{-34})(5,001 \times 10^{14}) \checkmark + \frac{1}{2}(9,11 \times 10^{-31})v^2 \checkmark$
 $\therefore v = 4,67 \times 10^5 \text{ m}\cdot\text{s}^{-1} \checkmark$
- OR/OF**
- $$E_k = E_{\text{light}} - W_0$$
- $$= hf_{\text{light}} - hf_0$$
- $$= (6,63 \times 10^{-34})(6,50 \times 10^{14} - 5,001 \times 10^{14}) \checkmark$$
- $$= 9,94 \times 10^{-20} \text{ J}$$
- $$E_k = \frac{1}{2}mv^2 \checkmark$$
- $$v = \sqrt{\frac{2E_k}{m}} = \sqrt{\frac{(2)(9,94 \times 10^{-20})}{9,11 \times 10^{-31}}} \checkmark$$
- $$v = 4,67 \times 10^5 \text{ m}\cdot\text{s}^{-1} \checkmark$$
- (5)
- 5.5 The photocurrent is directly proportional to the intensity of the incident light. $\checkmark \checkmark$ (2)

[12]

QUESTION 6

- 6.1.1 Light has a particle nature. \checkmark (1)
- 6.1.2 Remains the same. \checkmark
For the same colour/ frequency/wavelength the energy of the photons will be the same. \checkmark (The brightness causes more electrons to be released, but they will have the same maximum kinetic energy.)
OR Maximum kinetic energy of ejected photo-electrons is independent of intensity of radiation. (2)

6.1.3 $E = W_0 + E_k$
 $hf = hf_0 + E_k$
 $hf = hf_0 + \frac{1}{2}mv^2$
 $E = W_0 + \frac{1}{2}mv^2$ } ✓ Any one

$$\frac{(6,63 \times 10^{-34})(3 \times 10^8)}{420 \times 10^{-9}} \checkmark = \frac{(6,63 \times 10^{-34})(3 \times 10^8)}{\lambda_0} \checkmark + \frac{1}{2}(9,11 \times 10^{-31})(4,76 \times 10^5)^2 \checkmark$$

$\therefore \lambda_0 = 5,37 \times 10^{-7} \text{ m}$ \therefore the metal is sodium ✓ (5)

6.2 **Q** ✓ and **S** ✓

Emission spectra occur when excited atoms /electrons drop from higher energy levels to lower energy levels. ✓✓ (4)

(Characteristic frequencies are emitted.) [12]

QUESTION 7

7.1.1 The minimum frequency of a photon/light needed ✓ to emit electrons from the surface of a metal. ✓ (2)

7.1.2 Silver ✓

Threshold frequency / cut-off frequency (of Ag) is higher. ✓
 $W_0 \propto f_0 / W_0 = hf_0$ ✓ (3)

7.1.3 Planck's constant ✓ (1)

7.1.4 Sodium ✓ (1)

7.2.1 Energy radiated per second by the blue light = $\left(\frac{5}{100}\right)(60 \times 10^{-3}) \checkmark = 3 \times 10^{-3} \text{ J}\cdot\text{s}^{-1}$

$$E_{\text{photon}} = \frac{hc}{\lambda} \checkmark = \frac{(6,63 \times 10^{-34})(3 \times 10^8)}{470 \times 10^{-9}} \checkmark = 4,232 \times 10^{-19} \text{ J}$$

$$\text{Total number of photons incident per second} = \frac{3 \times 10^{-3}}{4,232 \times 10^{-19}} \checkmark = 7,09 \times 10^{15} \checkmark (5)$$

7.2.2 **POSITIVE MARKING FROM QUESTION 7.2.1.**

$7,09 \times 10^{15}$ (electrons per second) ✓ (1)

OR: Same number as that calculated in Question 7.2.1 above. [13]

QUESTION 8

8.1 It is the process whereby electrons are ejected from a metal surface when light of suitable frequency is incident on that surface. ✓✓ (2)

8.2 Increase ✓

Increase in intensity means that for the same frequency the number of photons incident per unit time increase. ✓ Therefore the number of electrons ejected per unit time increases. ✓ (3)

8.1.3

<p>OPTION 1</p> <p>$E = W_0 + E_{k(\text{max})}$ OR $hf = hf_0 + E_{k(\text{max})}$ OR $hf = hf_0 + \frac{1}{2}mv^2$ OR $E = W_0 + \frac{1}{2}mv^2 \checkmark$</p> <p>$(6,63 \times 10^{-34} \times 5,9 \times 10^{14}) \checkmark = \frac{(6,63 \times 10^{-34})(3 \times 10^8)}{\lambda_0} + 2,9 \times 10^{-19}$</p> <p>$39,117 \times 10^{-20} - 2,9 \times 10^{-19} = \frac{19,89 \times 10^{-26}}{\lambda_0} \quad \therefore \lambda_0 = 1,97 \times 10^{-6} \text{ m} \checkmark$</p>
<p>OPTION 2</p> <p>$E = W_0 + E_{k(\text{max})}$ OR $hf = hf_0 + E_{k(\text{max})}$ OR $hf = hf_0 + \frac{1}{2}mv^2$ OR $E = W_0 + \frac{1}{2}mv^2 \checkmark$</p> <p>$((6,63 \times 10^{-34} \times 5,9 \times 10^{14}) \checkmark = (6,63 \times 10^{-34})f_0 + 2,9 \times 10^{-19} \quad \therefore f_0 = 1,52 \times 10^{14} \text{ Hz}$</p> <p>$c = f_0\lambda_0 \quad \therefore 3 \times 10^8 = (1,52 \times 10^{14})\lambda_0 \checkmark \quad \therefore \lambda_0 = 1,97 \times 10^{-6} \text{ m} \checkmark$</p>
<p>OPTION 3</p> <p>$E = W_0 + E_{k(\text{max})}$ OR $hf = hf_0 + E_{k(\text{max})}$ OR $hf = hf_0 + \frac{1}{2}mv^2$ OR $E = W_0 + \frac{1}{2}mv^2 \checkmark$</p> <p>$(6,63 \times 10^{-34} \times 5,9 \times 10^{14}) \checkmark = W_0 + 2,9 \times 10^{-19} \quad \therefore W_0 = 1,01 \times 10^{-19} \text{ J}$</p> <p>$W_0 = hf_0 \quad \therefore 1,01 \times 10^{-19} = (6,63 \times 10^{-34})f_0 \quad \therefore f_0 = 1,52 \times 10^{14} \text{ Hz}$</p> <p>$c = f_0\lambda_0 \quad \therefore 3 \times 10^8 = (1,52 \times 10^{14})\lambda_0 \checkmark \quad \therefore \lambda_0 = 1,97 \times 10^{-6} \text{ m} \checkmark$</p>

(5)

- 8.4 From the photo-electric equation, for a constant work function, ✓ the energy of the photons is proportional to the maximum kinetic energy of the photoelectrons. ✓ (2) [12]

QUESTION 9

- 9.1 The minimum frequency of light ✓ needed to emit electrons from the surface of a metal. ✓ (2)
- 9.2 The speed remains unchanged. ✓ (1)

9.3

OPTION 1

$$c = f\lambda \quad \checkmark$$

$$\therefore 3 \times 10^8 = f(6 \times 10^{-7}) \quad \checkmark$$

$$\therefore f = 5 \times 10^{14} \text{ Hz} \quad \checkmark$$

The value of f is less than the threshold frequency of the metal, ✓ therefore photoelectric effect is not observed. ✓

OPTION 2

For the given metal:

$$W_0 = hf_0 \quad \checkmark = (6,63 \times 10^{-34})(6,8 \times 10^{14}) \quad \checkmark = 4,51 \times 10^{-19} \text{ J}$$

For the given wavelength:

$$E_{\text{photon}} = \frac{hc}{\lambda} = \frac{(6,63 \times 10^{-34})(3 \times 10^8)}{6 \times 10^{-7}} \quad \checkmark \quad \text{OR} \quad E_{\text{photon}} = hf = (6,63 \times 10^{-34})(5 \times 10^{14}) \quad \checkmark \checkmark$$

$$= 3,32 \times 10^{-19} \text{ J} \qquad \qquad \qquad = 3,32 \times 10^{-19} \text{ J}$$

Energy is less than work function ✓ of metal, therefore photoelectric effect not observed. ✓ (5)

9.4

$$\left. \begin{aligned} E &= W_0 + E_{k(\text{max})} \\ E &= W_0 + \frac{1}{2}mv_{\text{max}}^2 \\ h\frac{c}{\lambda} &= hf_0 + \frac{1}{2}mv_{\text{max}}^2 \\ hf &= hf_0 + \frac{1}{2}mv_{\text{max}}^2 \end{aligned} \right\} \text{Any one } \checkmark$$

$$(6,63 \times 10^{-34})(7,8 \times 10^{14}) \quad \checkmark = (6,63 \times 10^{-34})(6,8 \times 10^{14}) \quad \checkmark + \frac{1}{2}mv_{\text{max}}^2$$

$$\frac{1}{2}mv_{\text{max}}^2 = 6,63 \times 10^{-20} \text{ J}$$

$$\frac{1}{2}(9,11 \times 10^{-31})v_{\text{max}}^2 \quad \checkmark = 6,63 \times 10^{-20} \quad \therefore v_{\text{max}} = 3,82 \times 10^5 \text{ m}\cdot\text{s}^{-1} \quad \checkmark$$

(5) [13]

QUESTION 10

- 10.1.1 (Line) emission (spectrum) ✓ (1)
- 10.1.2 (Line) absorption (spectrum) ✓ (1)
- 10.2.1 Emission ✓ (1)
- 10.2.2 Energy released in the transition from E_4 to $E_2 = E_4 - E_2$
 $E_4 - E_2 = (2,044 \times 10^{-18} - 1,635 \times 10^{-18}) \quad \checkmark = 4,09 \times 10^{-19} \text{ J}$
 $E = hf \quad \checkmark \therefore 4,09 \times 10^{-19} = (6,63 \times 10^{-34})f \quad \checkmark \therefore f = 6,17 \times 10^{14} \text{ Hz} \quad \checkmark$ (4)

10.2.3 **POSITIVE MARKING FROM QUESTION 10.2.2.**

$$\left. \begin{aligned} E &= W_0 + E_{k(\text{max})} \\ hf &= hf_0 + E_{k(\text{max})} \\ hf &= hf_0 + \frac{1}{2}mv_{\text{max}}^2 \\ E &= W_0 + \frac{1}{2}mv_{\text{max}}^2 \end{aligned} \right\} \checkmark \text{Any one}$$

$$4,09 \times 10^{-19} \quad \checkmark = (6,63 \times 10^{-34})(4,4 \times 10^{14}) \quad \checkmark + E_{k(\text{max})} \quad \therefore E_{k(\text{max})} = 1,17 \times 10^{-19} \text{ J} \quad \checkmark$$

OR

$$\left. \begin{aligned} E_{k(\text{max})} &= E_{\text{light}} - W_0 \\ &= hf_{\text{light}} - hf_0 \end{aligned} \right\} \checkmark \text{Any one}$$

$$= (6,63 \times 10^{-34})(6,17 \times 10^{14}) \quad \checkmark - (6,63 \times 10^{-34})(4,4 \times 10^{14}) \quad \checkmark = 1,17 \times 10^{-19} \text{ J} \quad \checkmark$$
 (4)

10.2.4 **POSITIVE MARKING FROM QUESTION 10.2.2.**

No ✓
 -

The threshold frequency is greater than the frequency of the photon. ✓
OR: The frequency of the photon is less than the threshold frequency.
OR: Energy of the photon is less than the work function of the metal.

(2)
[13]

QUESTION 11

11.1.1 Greater than ✓
 Electrons are ejected from the metal plate. ✓ (2)

11.1.2 Increase in intensity implies that, for the same frequency, the number of photons per second increases (ammeter reading increases), ✓ but the energy of the photons stays the same. ✓
 Therefore the statement is incorrect.
OR An increase in energy of photons only increases kinetic energy of the photoelectrons and not the number of photoelectrons, thus the ammeter reading will not change. (2)

11.1.3 Light has a particle nature. (1)

11.2.1 The minimum frequency needed for the emission of electrons from the surface of a metal. ✓✓ (2)

11.2.2 $W_0 = hf_0$ ✓
 $= \frac{(6,63 \times 10^{-34})(5,73 \times 10^{14})}{3,8 \times 10^{-19} \text{ J}} = 3,799 \times 10^{-19} \text{ J}$ ✓ (3)

11.2.3 **POSITIVE MARKING FROM QUESTION 11.2.2.**

$$\left. \begin{aligned} E &= W_0 + E_{k(\text{max/maks})} \\ hf &= hf_0 + E_{k(\text{max/maks})} \\ hf &= hf_0 + \frac{1}{2} mv^2 \\ E &= W_0 + \frac{1}{2} mv^2 \end{aligned} \right\} \checkmark \text{ Any one/Enige een}$$

$$(6,63 \times 10^{-34})f = 3,8 \times 10^{-19} + [\frac{1}{2}(9,11 \times 10^{-31})(4,19 \times 10^5)^2] \checkmark$$

$$f = 6,94 \times 10^{14} \text{ Hz} \checkmark \quad [7 \times 10^{14} \text{ Hz}]$$

(3)
[13]

QUESTION 12

12.1 Work function (of a metal) is the minimum energy needed to eject an electron from the metal/surface. ✓✓ (2)

12.2 (Maximum) kinetic energy of the ejected electrons ✓ (1)

12.3 Wavelength/Frequency (of light) ✓ (1)

12.4 Silver ✓

- According to Photoelectric equation, $hf = W_0 + \frac{1}{2} mv^2$
 (For a given constant frequency), as the work function increases the kinetic energy decreases. ✓ Silver has the smallest kinetic energy ✓ and hence the highest work function. (3)

12.5 $hf = W_0 + \frac{1}{2} mv_{\text{max/maks}}^2$ **OR** $h \frac{c}{\lambda} = W_0 + E_{k(\text{max/maks})}$ ✓
 $\frac{(6,63 \times 10^{-34})(3 \times 10^8)}{2 \times 10^{-8}} \checkmark = W_0 + 9,58 \times 10^{-18} \checkmark$
 $9,945 \times 10^{-18} = W_0 + 9,58 \times 10^{-18} \therefore W_0 = 3,65 \times 10^{-19} \text{ J} \checkmark$ (4)

12.6 Remains the same ✓

- Increasing intensity increases number of photons (per unit time), but frequency stays constant ✓ and energy of photon is the same. ✓ Therefore the kinetic energy does not change. (3)
[14]

QUESTION 13

13.1 Work function of a metal is the minimum energy needed to eject an electron from the metal surface. ✓✓ (2)

13.2 Potassium / K ✓
 - f_0 for potassium is greater than f_0 for caesium ✓
OR Work function is directly proportional to threshold frequency ✓ (2)

13.3

OPTION 1
 $c = f\lambda \checkmark \therefore 3 \times 10^8 = f(5,5 \times 10^{-7}) \checkmark \therefore f = 5,45 \times 10^{14} \text{ Hz} \therefore f_{\text{uv}} < f_0 \text{ of K(potassium)}$
 \therefore Ammeter in circuit **B** will not show a reading \checkmark

OPTION 2
 $E = \frac{hc}{\lambda} = \frac{(6,63 \times 10^{-34})(3 \times 10^8)}{5,5 \times 10^{-7}} = 3,6164 \times 10^{-19} \text{ J}$
 $W_0 = hf_0 \checkmark = (6,63 \times 10^{-34})(5,55 \times 10^{14}) \checkmark = 3,68 \times 10^{-19} \text{ J}$
 $W_0 > E$ or $hf_0 > hf \therefore$ The ammeter will not register a current \checkmark

OPTION 3
 $c = f_0\lambda_0 \checkmark$
 $3 \times 10^8 = (5,55 \times 10^{14})\lambda \checkmark$
 $\lambda_0 = 5,41 \times 10^{-7} \text{ m}$
 $\lambda_0(\text{threshold}) < \lambda(\text{incident}) \therefore$ the ammeter will not register a current \checkmark

(3)

13.4

OPTION 1
 $E = W_0 + E_{k(\text{max})} \text{ OR } hf = hf_0 + \frac{1}{2}mv_{\text{max}}^2 \text{ OR } h\frac{c}{\lambda} = h\frac{c}{\lambda_0} + E_{k(\text{max})} \checkmark$
 $\frac{(6,63 \times 10^{-34})(3 \times 10^8)}{5,5 \times 10^{-7} \checkmark} = (6,63 \times 10^{-34})(5,07 \times 10^{14}) + E_{k(\text{max})}$
 $E_K = 2,55 \times 10^{-20} \text{ J} \checkmark \checkmark \quad (\text{Range: } 2,52 \times 10^{-20} - 2,6 \times 10^{-20} \text{ J})$

OPTION 2
POSITIVE MARKING FROM QUESTION 11.3.
 $E = W_0 + E_{k(\text{max})} \text{ OR } hf = hf_0 + \frac{1}{2}mv_{\text{max}}^2 \text{ OR } h\frac{c}{\lambda} = h\frac{c}{\lambda_0} + E_{k(\text{max})} \checkmark$
 $(6,63 \times 10^{-34})(5,45 \times 10^{14}) \checkmark \checkmark = (6,63 \times 10^{-34})(5,07 \times 10^{14}) + E_{k(\text{max})} \checkmark$
 $E_K = 2,52 \times 10^{-20} \text{ J} \checkmark \quad (\text{Range: } 2,52 \times 10^{-20} - 2,6 \times 10^{-20} \text{ J})$

(5)

13.5

Remains the same \checkmark

(1)

[13]

BIBLIOGRAPHY

Department of Basic Education, *National Senior Certificate Physical Sciences Question Papers*, 2014 – 2018, Pretoria